

# WELDER

(NSQF Level - 3)

Volume I of II

---

## TRADE PRACTICAL

---

**Sector : Capital Goods & Manufacturing**

(Common for Welder (Pipe), Welder (Structural),  
Welder (Fabrication & Fitting) and Welder (Welding Inspection))



Directorate General of Training

DIRECTORATE GENERAL OF TRAINING  
MINISTRY OF SKILL DEVELOPMENT & ENTREPRENEURSHIP  
GOVERNMENT OF INDIA



**NATIONAL INSTRUCTIONAL  
MEDIA INSTITUTE, CHENNAI**

---

Post Box No. 3142, CTI Campus, Guindy, Chennai - 600 032.

**Sector : Capital Goods & Manufacturing**

**Duration : 1 - Year**

**Trade : Welder Volume I of II - Trade Practical - NSQF LEVEL - 3**

**Developed & Published by**



**National Instructional Media Institute**

Post Box No.3142

Guindy, Chennai - 600 032

INDIA

Email: [chennai-nimi@nic.in](mailto:chennai-nimi@nic.in)

Website: [www.nimi.gov.in](http://www.nimi.gov.in)

Copyright © 2022 National Instructional Media Institute, Chennai

First Edition : March 2022

Copies : 50

**Rs.215/-**

## FOREWORD

The Government of India has set an ambitious target of imparting skills to 30 crores people, one out of every four Indians, by 2020 to help them secure jobs as part of the National Skills Development Policy. Industrial Training Institutes (ITIs) play a vital role in this process especially in terms of providing skilled manpower. Keeping this in mind, and for providing the current industry relevant skill training to Trainees, ITI syllabus has been recently updated with the help of comprising various stakeholder's viz. Industries, Entrepreneurs, Academicians and representatives from ITIs.

The National Instructional Media Institute (NIMI), Chennai has now come up with instructional material to suit the revised curriculum for **Welder Volume I of II (Common for Welder (Pipe), Welder (Structural), Welder (Fabrication & Fitting) and Welder (Welding Inspection)) Trade Practical NSQF Level - 3 in Capital Goods & Manufacturing Sector under Semester Pattern**. The NSQF Level - 3 Trade Practical will help the trainees to get an international equivalency standard where their skill proficiency and competency will be duly recognized across the globe and this will also increase the scope of recognition of prior learning. NSQF Level - 3 trainees will also get the opportunities to promote life long learning and skill development. I have no doubt that with NSQF Level - 3 the trainers and trainees of ITIs, and all stakeholders will derive maximum benefits from these IMPs and that NIMI's effort will go a long way in improving the quality of Vocational training in the country.

The Executive Director & Staff of NIMI and members of Media Development Committee deserve appreciation for their contribution in bringing out this publication.

Jai Hind

**SHRI. ATUL KUMAR TIWARI., I.A.S.,**

Director General/Additional Secretary  
Directorate General of Training  
Ministry of Skill Development & Entrepreneurship  
Government of India.

New Delhi - 110 001

## PREFACE

The National Instructional Media Institute (NIMI) was established in 1986 at Chennai by then Directorate General of Employment and Training (D.G.E & T), Ministry of Labour and Employment, (now under Directorate General of Training, Ministry of Skill Development and Entrepreneurship) Government of India, with technical assistance from the Govt. of the Federal Republic of Germany. The prime objective of this institute is to develop and provide instructional materials for various trades as per the prescribed syllabi (NSQF) under the Craftsman and Apprenticeship Training Schemes.

The instructional materials are created keeping in mind, the main objective of Vocational Training under NCVT/NAC in India, which is to help an individual to master skills to do a job. The instructional materials are generated in the form of Instructional Media Packages (IMPs). An IMP consists of Theory book, Practical book, Test and Assignment book, Instructor Guide, Audio Visual Aid (Wall charts and Transparencies) and other support materials.

The trade practical book consists of series of exercises to be completed by the trainees in the workshop. These exercises are designed to ensure that all the skills in the prescribed syllabus are covered. The trade theory book provides related theoretical knowledge required to enable the trainee to do a job. The test and assignments will enable the instructor to give assignments for the evaluation of the performance of a trainee. The wall charts and transparencies are unique, as they not only help the instructor to effectively present a topic but also help him to assess the trainee's understanding. The instructor guide enables the instructor to plan his schedule of instruction, plan the raw material requirements, day to day lessons and demonstrations.

In order to perform the skills in a productive manner instructional videos are embedded in QR code of the exercise in this instructional material so as to integrate the skill learning with the procedural practical steps given in the exercise. The instructional videos will improve the quality of standard on practical training and will motivate the trainees to focus and perform the skill seamlessly.

IMPs also deals with the complex skills required to be developed for effective team work. Necessary care has also been taken to include important skill areas of allied trades as prescribed in the syllabus.

The availability of a complete Instructional Media Package in an institute helps both the trainer and management to impart effective training.

The IMPs are the outcome of collective efforts of the staff members of NIMI and the members of the Media Development Committees specially drawn from Public and Private sector industries, various training institutes under the Directorate General of Training (DGT), Government and Private ITIs.

NIMI would like to take this opportunity to convey sincere thanks to the Directors of Employment & Training of various State Governments, Training Departments of Industries both in the Public and Private sectors, Officers of DGT and DGT field institutes, proof readers, individual media developers and coordinators, but for whose active support NIMI would not have been able to bring out this materials.

**Chennai - 600 032**

**EXECUTIVE DIRECTOR**

## ACKNOWLEDGEMENT

National Instructional Media Institute (NIMI) sincerely acknowledges with thanks for the co-operation and contribution extended by the following Media Developers and their sponsoring organizations to bring out this Instructional Material (**Trade Practical**) for the trade of **Welder Volume I of II (Common for Welder (Pipe), Welder (Structural), Welder (Fabrication & Fitting) and Welder (Welding Inspection))** (NSQF) under **Capital Goods & Manufacturing** Sector.

### MEDIA DEVELOPMENT COMMITTEE MEMBERS

Shri. S. Suresh Kumar	–	Principal, Karthikeyan ITI, Perambalur.
Shri. S. Dasarathan	–	Retd. Instructor, TTC, ICF Chennai -38 MDC Member-NIMI.
Shri. D. Justin David Raj	–	Instructor, Nirmala ITI, Manalickarai.
Shri. P. Manjunatha	–	Junior Training Officer, Govt - ITI, Mysore - 07.
Shri. G. Sangareeswari	–	Junior Training Officer, Govt - ITI - Guindy.

### NIMI CO-ORDINATORS

Shri. Nirmalya Nath	-	Deputy Director, NIMI, Chennai - 32.
Shri. V. Gopalakrishnan	-	Assistant Manager NIMI, Chennai - 32.

NIMI records its appreciation of the Data Entry, CAD, DTP Operators for their excellent and devoted services in the process of development of this Instructional Material.

NIMI also acknowledges with thanks, the invaluable efforts rendered by all other staff who have contributed for the development of this Instructional Material.

NIMI is grateful to all others who have directly or indirectly helped in developing this IMP.

# INTRODUCTION

## TRADE PRACTICAL

The trade practical manual is intended to be used in workshop . It consists of a series of practical exercises to be completed by the trainees during the one year course of the **Welder Volume I of II (Common for Welder (Pipe), Welder (Structural), Welder (Fabrication & Fitting) and Welder (Welding Inspection))** under **Capital Goods & Manufacturing** Sector. Trade supplemented and supported by instructions/ informations to assist in performing the exercises. These exercises are designed to ensure that all the skills in compliance with NSQF LEVEL - 3. The manual is divided into Three modules.

Module No	Module Name	Hrs
Module 1	Indian Training and Welding Process OAW, SMAW	117 Hrs
Module 2	Welding Techniques	75 Hrs
Module 3	Welder of steels OAW, SMAW	333 Hrs
<b>Total</b>		<b>525 Hrs</b>

The skill training in the shop floor is planned through a series of practical exercises centred around some practical project. However, there are few instances where the individual exercise does not form a part of project.

While developing the practical manual a sincere effort was made to prepare each exercise which will be easy to understand and carry out even by below average trainee. However the development team accept that there is a scope for further improvement. NIMI, looks forward to the suggestions from the experienced training faculty for improving the manual.

## TRADE THEORY

The manual of trade theory consists of theoretical information for the one year course of the **Welder Volume I of II (Common for Welder (Pipe), Welder (Structural), Welder (Fabrication & Fitting) and Welder (Welding Inspection))** Trade. The contents are sequenced according to the practical exercise contained in the manual on Trade practical. Attempt has been made to relate the theoretical aspects with the skill covered in each exercise to the extent possible. This co-relation is maintained to help the trainees to develop the perceptual capabilities for performing the skills.

The Trade theory has to be taught and learnt along with the corresponding exercise contained in the manual on trade practical. The indicating about the corresponding practical exercise are given in every sheet of this manual.

It will be preferable to teach/learn the trade theory connected to each exercise atleast one class before performing the related skills in the shop floor. The trade theory is to be treated as an integrated part of each exercise.

The material is not the purpose of self learning and should be considered as supplementary to class room instruction.

## CONTENTS

Exercise No.	Title of the Exercise	Page No.
	<b>Module 1 : INDUCTION TRAINING AND WELDING PROCESS (OAW, SMAW)</b>	
1.1.01	Identification of machinery used in welding trade	1
1.1.02	Identification of safety equipment and their uses	6
<b>1.1.03</b>	<b>Hack sawing, filling square to dimension (OR Code Pg.No. 13)*</b>	<b>8</b>
1.1.04	Marking out on MS plate and punching	14
<b>1.1.05</b>	<b>Setting of oxy-acetylene welding (OR Code Pg.No. 23)*</b>	<b>17</b>
1.1.06	Perform fusion run without filler rod on MS sheet 2mm thick in flat position (OAW-01)	24
1.1.07	Setting of arc welding machine & accessories and striking an arc (SMAW-01)	26
1.1.08	Deposit straight line bead on MS plate in flat position	32
1.1.09	Depositing bead with filler rod on MS sheet 2mm thick in flat position	36
<b>1.1.10</b>	<b>Edge joint on MS sheet 2mm thick in flat position without filler rod (OAW-03) (OR Code Pg.No. 42)*</b>	<b>41</b>
1.1.11	Straight line beads on MS plate 10mm thick in flat position (SMAW - 02)	43
1.1.12	Weaved beads on MS plate 10mm thick in flat position (SMAW-03)	47
1.1.13	Setting of Oxy - Acetylene and make straight cuts (free hand)	51
1.1.14	Perform making straight line cutting of MS plate 10mm thick by gas accuracy within $\pm 2$ mm	54
<b>1.1.15</b>	<b>Beveling of MS plates 10mm thick cutting regular geometrical shapes and irregular shapes cutting chamfers by gas cutting (OR Code Pg.No. 65)*</b>	<b>58</b>
1.1.16	Circular gas cutting on MS plate 10mm thick by profile cutting machine (OAGC-03)	66
1.1.17	Marking and perform radial cuts, cutting out holes using oxy-acetylene gas cutting	69
<b>1.1.18</b>	<b>Identification of cutting defects viz, distortion, grooved, fluted or ragged cuts, poor draglines, rounded edges, tightly adhering slag (OAGC-06) (OR Code Pg.No. 72)*</b>	<b>71</b>
	<b>Module 2 : WELDING TECHNIQUES</b>	
1.2.19	Square butt joint on MS sheet 2 mm thick in flat position (1G) (OAW-04)	73
1.2.20	Fillet "T" joint on MS plate 10mm thick in flat position (1F)-(SMAW-04)	76

Exercise No.	Title of the Exercise	Page No.
1.2.21	Open corner joint on M.S. sheet 2 mm thick in flat position (1F)-(OAW-05)	79
1.2.22	Fillet lap joint on MS plate 10mm thick in flat position (1F)-(SMAW-05)	82
1.2.23	Fillet 'T' joint on M.S. sheet 2mm thick in flat position (1F)-(OAW-06)	85
1.2.24	Open corner joint on MS plate 10mm thick in flat position (1F)-(SMAW-06)	88
<b>1.2.25</b>	<b>Fillet lap joint on MS sheet 2mm thick in flat position (1F)-(OAW-07) (OR Code Pg.No. 94)*</b>	<b>92</b>
1.2.26	Single "V" butt joint on MS plate 12mm thick in flat position (1G)-(SMAW-07)	95
<b>Module 3 : WELD ABILITY OF STEELS (OAW, SMAW)</b>		
1.3.27	Testing of weld joint by visual inspection (I&T-01)	98
1.3.28	Inspection of welds using weld gauges (I&T-01)	102
1.3.29	Square butt joint on MS sheet 2mm thick in horizontal position (2G)-(OAW-08)	106
1.3.30	Straight line beads and multi layer practice on M.S. plate 10mm thick in horizontal position (SMAW-08)	108
1.3.31	Fillet - 'T' joint on MS plate 10mm thick in horizontal position (2F)-(SMAW-09)	110
1.3.32	Fillet - lap joint on MS sheet 2mm thick in horizontal position (2F)-(OAW-09)	113
1.3.33	Fillet lap joint on MS plate 10mm thick in horizontal position (2F)-(SMAW-10)	115
1.3.34	Fusion run with filler rod in vertical position on 2mm thick MS sheet (OAW-10)	117
<b>1.3.35</b>	<b>Square butt joint on MS sheet 2mm thick in vertical position (3G)-(OAW-11)(OR Code Pg.No. 121)*</b>	<b>120</b>
1.3.36	Single "V" butt joint on MS plate 12mm thick in horizontal position (2G)-(SMAW-11)	122
1.3.37	Weaved beads on MS plate 10mm thick in vertical position (SMAW-12)	125
<b>1.3.38</b>	<b>Fillet 'T' joint on MS sheet 2mm thick in vertical position (3F)-(OAW-12)(OR Code Pg.No. 132)*</b>	<b>130</b>
1.3.39	Fillet - "T" joint on MS plate 10mm thick in vertical position (3F)-(SMAW-13)	133
<b>1.3.40</b>	<b>Structural pipe welding butt joint on MS pipe ø50mm × 3mm wall thickness in 1G (Rolling) position (OAW-13) (OR Code Pg.No. 138)*</b>	<b>136</b>
1.3.41	Fillet - lap joint on MS plate 10mm in vertical position (3G)-(SMAW-14)	139



Exercise No.	Title of the Exercise	Page No.
1.3.42	Open corner joint on MS plate 10mm thick in vertical position (3F)-(SMAW-15)	142
1.3.43	Pipe welding - Elbow joint on MS pipe $\varnothing$ 50mm and 3mm wall thickness in flat position (1G)-(OAW-14)	145
1.3.44	Pipe welding 'T' joint on MS pipe $\varnothing$ 50mm and 3mm wall thickness in flat position (1G) - (OAW-15)	147
1.3.45	Single "V" butt joint on MS plate 12mm thick in vertical position (3G)-(SMAW-16)	149
1.3.46	Pipe welding 45° angle joint on M.S. pipe $\varnothing$ 50mm and 3mm wall thickness (1G)-(OAW-16)	152
1.3.47	Straight line beads on MS plate 10mm thick in over head position (SMAW-17)	155
1.3.48	Pipe flange joint on MS plate with MS pipe $\varnothing$ 50mm x 3mm wall thickness (1F) (SMAW-18)	158
1.3.49	Fillet - "T" joint on MS plate 10mm thick in over head position (4F)-(SMAW-19)	162
1.3.50	Pipe welding butt joint on MS pipe $\varnothing$ 50mm and 5mm wall thickness in 1G position (SMAW-20)	165
1.3.51	Fillet - lap joint on MS plate 10mm thick in over head position (4G)-(SMAW-21)	168
1.3.52	Single "V" butt joint on MS plate 10mm thick in over head position (4G)-(SMAW-22)	170
1.3.53	Pipe butt joint on MS pipe $\varnothing$ 50mm wall thickness 6mm (1G Rolled) position (SMAW-23)	173
1.3.54	Square butt joint on stainless steel sheet 2.0mm thick in flat position (1G)-(OAW-17)	176
1.3.55	Square but joint on stainless steel sheet 2mm thick in flat position (SMAW-24)	178
1.3.56	Square butt joint on brass sheet 2mm thick in flat position (OAW-18)	180
1.3.57	Square butt and lap joint on M.S. sheet 2mm thick by brazing in flat position (OAW-19)	182
1.3.58	Single "V" butt joint on cast iron plate 6mm thick in flat position (1G) (SMAW-25)	184
1.3.59	Arc gouging on MS plate 10mm thick (AG-01)	187
1.3.60	Square butt joint on aluminium sheet 3mm thick in flat position (OAW-20)	189
1.3.61	Bronze welding of single "V" butt joint on cast iron plate 6mm thick plate (1G) (OAW-21)	192

**\* Steps to download and scan the Quick Response (QR) code**

- Download QR Code app on your phone
- Run app and scan the QR code
- Your smartphone will read the code and navigate to the destination

## LEARNING/ ASSESSABLE OUTCOME

On completion of this book you shall be able to

- **Set the gas welding plant and join MS sheet in different position [Different position:1F, 2F, 3F, 1G, 2G, 3G]**
- **Set the SMAW machine and perform different type of joints on MS in different position observing standard procedure [Different types of joints- Fillet (T-joint, lap & Corner), Butt (Square & V); different position - 1F, 2F, 3F,4F, 1G, 2G, 3G, 4G]**
- **Set the oxy- acetylene cutting plant and perform different cutting operations on MS plate [Different cutting operation - Straight, Bevel, circular]**
- **Perform welding in different types of MS pipe joints by Gas welding (OAW) [Different types of MS pipe joints - Butt, Elbow, T-joint, angle (45) joint, flange joint]**
- **Set the SMAW machine and perform welding in different types of MS pipe joints by SMAW [Different types of MS pipe joints - Butt, Elbow, T-joint, angle (45) joint, flange joint]**
- **Choose appropriate welding process and perform joining of different types of metals and check its correctness [appropriate welding process - OAW, SMAW; Different metal - SS, CI, Brass, Aluminium]**
- **Demonstrate arc gouging operation to rectify the weld joints.**

# SYLLABUS

Volume I of II

Duration: Six months

Week No.	Ref. Learning Outcome	Process Code	Professional Skills (Trade Practical) with Indicative hours	Professional Knowledge (Trade Theory)
1			1 Demonstration of Machinery used in the trade (06 hrs) 2 Identification to safety equipment and their use etc. (04 hrs) 3 Hack sawing, filing square to dimensions (07 hrs) 4 Marking out on MS plate and punching (08 hrs)	<ul style="list-style-type: none"> <li>- Importance of Trade Training</li> <li>- General discipline in the Institute</li> <li>- Elementary First Aid</li> <li>- Importance of Welding in Industry</li> <li>- Safety precautions in Shielded</li> </ul>
2	9 Set the gas welding plant and join MS sheet in different position [Different position: 1F, 2F, 3F, 1G, 2G, 3G] 10 Set the SMAW machine and perform different type of joints on MS in different position observing standard procedure [different types of joints- Fillet (T-joint, lap & Corner), Butt (Square & V); different position - 1F, 2F, 3F, 4F, 1G, 2G, 3G, 4G]	OAW-01  SMAW-01	5 Setting of oxy-acetylene welding equipment, Lighting and setting of flame (02 hrs) 6 Perform fusion run without filler rod on MS sheet 2mm thick in flat position (02 hrs) 7 Setting up of Arc welding machine & accessories and striking an arc (02 hrs) 8 Deposit straight line bead on MS plate in flat position (02 hrs)	<ul style="list-style-type: none"> <li>- Introduction and definition of welding</li> <li>- Arc and Gas Welding Equipments, tools and accessories</li> <li>- Various Welding Processes and its applications</li> <li>- Arc and Gas Welding terms and definitions</li> </ul>
3	9 Set the gas welding plant and join MS sheet in different position [Different position: 1F, 2F, 3F, 1G, 2G, 3G]	OAW-02  OAW-03	9 Depositing bead with filler rod on M.S. sheet 2 mm thick in flat position (10 hrs) 10 Edge joint on MS sheet 2 mm thick in flat position without filler rod (15 hrs)	<ul style="list-style-type: none"> <li>- Different process of metal joining method: Bolting, riveting, soldering, brazing, seaming etc.</li> <li>- Types of welding joints and its applications. Edge preparation and fit up for different thickness</li> <li>- Surface Cleaning</li> </ul>
4	10 Set the SMAW machine and perform different type of joints on MS in different position observing standard procedure [Different types of joints-Fillet (T-joint Clap & Corner), Butt (Square & V); different position S1F, 2F, 3F, 4F, 1G, 2G, 3G, 4G]	SMAW-02  SMAW-03	11 Straight line beads on M.S. plate 10 mm thick in flat position (10 hrs) 12 Weaved bead on M. S plate 10mm thick in flat position (15 hrs)	<ul style="list-style-type: none"> <li>- Basic electricity applicable to arc welding and related electrical terms &amp; definitions</li> <li>- Heat and temperature and its terms related to welding</li> <li>- Principle of arc welding. And characteristics of arc</li> </ul>
5	11 Set the oxy-acetylene cutting plant and perform different cutting operations on MS plate [Different cutting operation - Straight, Bevel, circular]	OAGC-01  OAGC-02  OAGC-03	13 Setting up of oxy-acetylene and make straight cuts (freehand) (02 hrs) 14 Perform marking and straight line cutting of MS plate 10 mm thick by gas. Accuracy within $\pm 2$ mm (04 hrs)	<ul style="list-style-type: none"> <li>- Common gases used for welding &amp; cutting, flame temperatures and uses</li> <li>- Chemistry of oxy-acetylene flame</li> <li>- Types of oxy-acetylene flames and uses</li> </ul>

		OAGC-04	15 Beveling of MS plates 10 mm thick, cutting regular geometrical shapes and irregular shapes, cutting chamfers by gas cutting (07 hrs)	- Oxy-Acetylene Cutting Equipment principle, parameters and application
		OAGC-05	16 Circular gas cutting on MS plate 10 mm thick by profile cutting machine (07 hrs)	
		OAGC-06	17. Marking and perform radial cuts, cutting out holes using oxy-acetylene gas cutting (03 hrs) 18 Identify cutting defects viz., distortion, grooved, fluted or ragged cuts; poor draglines; rounded edges; tightly adhering slag (02 hrs)	
6	9 Set the gas welding plant and join MS sheet in different position [Different position: 1F, 2F, 3F, 1G, 2G, 3G] 10 Set the SMAW machine and perform different type of joints on MS in different position observing standard procedure [different types of joints- Fillet (T-joint, lap & Corner), Butt (Square & V); different position - 1F, 2F, 3F, 4F, 1G, 2G, 3G, 4G]	OAW-04	19 Square butt joint on M.S. sheet 2 mm thick in flat position (1G) (8 hrs)	- Arc welding power sources: Transformer, Motor Generator set, Rectifier and Inverter type welding machines and its care & maintenance  - Advantages and disadvantages of A.C. and D.C. welding machines
		SMAW-04	20 Fillet "T" joint on M.S. Plate 10 mm thick in flat position. (1F) (08 hrs) 21 Open corner joint on MS sheet 2 mm thick in flat Position (1F) (09 hrs)	
		OAW-05		
7		SMAW-05	22 Fillet lap joint on M.S. plate 10 mm thick in flat position. (1F) (08 hrs)	- Welding positions as per EN & ASME: flat, horizontal, vertical and overhead position  - Weld slope and rotation  - Welding symbols as per BIS & AWS
		OAW-06	23 Fillet "T" joint on MS sheet 2 mm thick in flat position. (1F) (08 hrs)	
		SMAW-06	24 Open Corner joint on MS plate 10 mm thick in flat position (1F) (09 hrs)	
8		OAW-07	25 Fillet Lap joint on MS sheet 2 mm thick in flat position (1F) (10 hrs)	- Arc length - types - effects of arc length  - Polarity: Types and applications  - Weld quality inspection, common welding mistakes and appearance of good and defective welds  - Weld gauges & its uses
		SMAW-07	26 Single "V" Butt joint on MS plate 12 mm thick in flat position (1G) (13 hrs)	
		I&T-01	27 Testing of weld joints by visual inspection (01 hr) 28 Inspection of welds by using weld gauges (01 hr)	
9		OAW-08	29. Square Butt joint on M.S. sheet. 2 mm thick in Horizontal position. (2G) (10 hrs)	- Calcium carbide properties and uses  - Acetylene gas properties and generating methods  - Acetylene gas Purifier, Hydraulic back pressure valve and Flash back arrestor
		SMAW-08	30. Straight line beads and multi-layer practice on M.S. Plate 10 mm thick in Horizontal position (06 hrs)	
		SMAW-09	31 Fillet "T" joint on M.S. plate 10 mm thick in Horizontal position (2F) (09 hrs)	

10	-do-	OAW-09 SMAW-10	32 Fillet Lap joint on M.S. sheet 2 mm thick in horizontal position(2F) (12 hrs) 33 Fillet Lap joint on M.S. plate 10 mm thick in horizontal position (13 hrs) (2F)	<ul style="list-style-type: none"> <li>- Oxygen gas and its properties</li> <li>- Production of oxygen by Air liquefaction</li> <li>- Charging process of oxygen and acetylene gases</li> <li>- Oxygen and Dissolved Acetylene gas cylinders and Color coding for different gas cylinders</li> <li>- Gas regulators, types and uses</li> </ul>
11	-do-	OAW-10 OAW-11 SMAW-11	34 Fusion run with filler rod in vertical position on 2mm thick M.S sheet (08hrs) 35 Square Butt joint on M.S. sheet. 2 mm thick in vertical position (3G) (08 hrs) 36 Single Vee Butt joint on M.S. plate 12 mm thick in horizontal position (2G) (09 hrs)	<ul style="list-style-type: none"> <li>- Oxy acetylene gas welding Systems (Low pressure and High pressure)</li> <li>- Difference between gas welding blow pipe(LP &amp; HP) and gas cutting blow pipe</li> <li>- Gas welding techniques Rightward and Leftward techniques</li> </ul>
12	-do-	SMAW- 12 OAW-12 SMAW-13	37 Weaved bead on M.S Plate 10mm in vertical position(08 hrs) 38 Fillet "T" joint on M.S sheet 2 mm thick in vertical position (3F) (08 hrs) 39 Fillet "T" joint on M.S. plate 10 mm thick in vertical position (3F) (09 hrs)	<ul style="list-style-type: none"> <li>- Arc blow - causes and methods of controlling</li> <li>- Distortion in arc &amp; gas welding and methods employed to minimize distortion</li> <li>- Arc Welding defects, causes and Remedies</li> </ul>
13	10 Set the S M A W machine and perform different type of joints on MS in different position observing standard procedure. [different types of joints- Fillet (T-joint, lap & Corner), Butt (Square & V); different position - 1F, 2F, 3F,4F, 1G, 2G, 3G, 4G]	OAW-13 SMAW-14	40 Structural pipe welding butt joint on MS pipe Ø 50 and 3mm WT in 1G position (15 hrs) 41 Fillet Lap joint on M.S. Plate 10 mm in vertical position (3G) (10 hrs)	<ul style="list-style-type: none"> <li>- Specification of pipes, various types of pipe joints, pipe welding all positions, and procedure</li> <li>- Difference between pipe welding and platewelding</li> </ul>
14		SMAW-15 OAW-14	42 Open Corner joint on MS plate 10 mm thick in vertical position.(2F) (10 hrs) 43 Pipe welding - Elbow joint on MS pipe Ø 50 and 3mm WT (1G) (15 hrs)	<ul style="list-style-type: none"> <li>- Pipe development for Elbow joint, "T" joint, Y joint and branch joint</li> <li>- Manifold system</li> </ul>
15		OAW-15 SMAW-16	44 Pipe welding "T" joint on MS pipe Ø 50 and 3mm WT (1G) (10 hrs) 45 Single "V" Butt joint on MS plate 12 mm thick in vertical position (3G) (15 hrs)	<ul style="list-style-type: none"> <li>- Gas welding filler rods, specifications and sizes.</li> <li>- Gas welding fluxes - types and functions.</li> <li>- Gas Brazing &amp; Soldering : principles, types fluxes &amp; uses</li> <li>- Gas welding defects, causes and remedies.</li> </ul>
16		12 Perform welding in different types of MS pipe joints by Gas welding ( O A W ) . [Different types of MS pipe joints -	OAW-16 SMAW-17	46 Pipe welding 45° angle joint on MS pipe Ø 50 and 3mm WT (1G) (15 hrs) 47 Straight line beads on M.S. plate 10mm thick in overhead position (10 hrs)

17	10 Set the SMAW machine and perform different type of joints on MS in different positions observing standard procedure [Different types of joints - Fillet (T-joint, lap & Corner), Butt (Square & V); different position- 1F, 2F, 3F,4F, 1G, 2G, 3G, 4G]	SMAW-18 SMAW-19	48 Pipe Flange joint on M.S plate with MS pipe Ø 50 mm X 3mm WT (1F) (15 hrs) 49 Fillet "T" joint on M.S. plate 10 mm thick in overhead position (4F) (10 hrs)	- Weldability of metals, importance of pre-heating, post heating and maintenance of interpass temperature
18	13 Set the SMAW machine and perform welding in different types of MS pipe joints by SMAW [Different types of MS pipe joints-Butt, Elbow, T-joint, angle (45 ) joint, flange joint]	SMAW-20	50 Pipe welding butt joint on MS pipe Ø 50 and 5 mm WT. in 1G position (15 hrs) 51 Fillet Lap joint on M.S. plate 10 mm thick in overhead position (4G) (10 hrs)	- Classification of steel - Welding of low, medium and high carbon steel and alloy steels
19		SMAW-20 SMAW-21 SMAW-22 MAW-23	52 Single "V" Butt joint on MS plate 10mm thick in overhead position (4G) (15 hrs). 53 Pipe butt joint on M. S. pipe Ø 50mm WT 6mm (1G Rolled)(10 hrs)	- Effects of alloying elements on steel - Stainless steel: Types - weld decay and weldability
20	14 Choose appropriate welding process and perform joining of different types of metals and check its correctness [Appropriate welding process - OAW, SMAW; Different metal - SS, CI, Brass, Aluminium]	OAW-17 SMAW -24 OAW-18	54 Square Butt joint on S.S. sheet. 2 mm thick in flat position (1G) (08 hrs) 55 Square Butt joint on S.S. Sheet 2 mm thick in flat position(1G) (08 hrs) 56 Square Butt joint on Brass sheet 2 mm thick in flat position (1G) (09 hrs)	- Brass - types - properties and welding methods - Copper - types - properties and welding methods
21	14 Choose appropriate welding process and perform joining of different types of metals and check its correctness [Appropriate welding process-OAW, SMAW; Different metal-SS,CI, Brass, Aluminium] 15 Demonstrate arc gauging operation to rectify the weld joints	OAW-19 SMAW-25 AG-01	57 Square Butt & Lap joint on M.S. sheet 2 mm thick by brazing in flat position (11 hrs) 58 Single "V" butt joint C.I. plate 6mm thick in flat position (1G)(11 hrs) 59 Arc gouging on MS plate 10 mm thick (03 hrs)	- Aluminium and its alloys, properties and weldability, Welding methods - Arc cutting & gouging
22	14 Choose appropriate welding process and perform joining of different types of metals and check its correctness. [appropriate welding process - OAW, SMAW; Different metal - SS, CI, Brass, Aluminium]	OAW-20 OAW-21	60 Square Butt joint on Aluminium sheet. 3 mm thick in flat position. (12 hrs) 61 Bronze welding of cast iron (Single "V" butt joint) 6mm thick plate (1G) (13 hrs)	- Cast iron and its properties types - Welding methods of cast iron
<b>Revision</b>				
<b>Examination</b>				



Demonstration of machinery used in welding trades

Objectives: At the end of this exercise you shall be able to

- name the machinery used in welding shop
- record the name and its uses of each machine in given table.

Fig 1

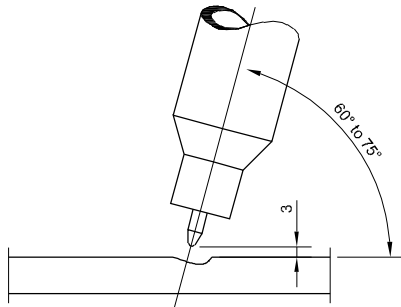


Fig 2

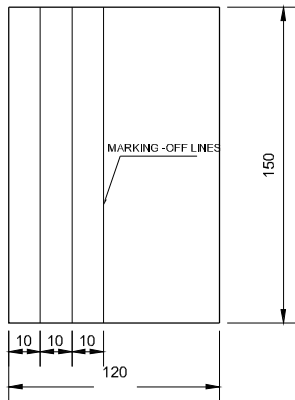


Fig 3

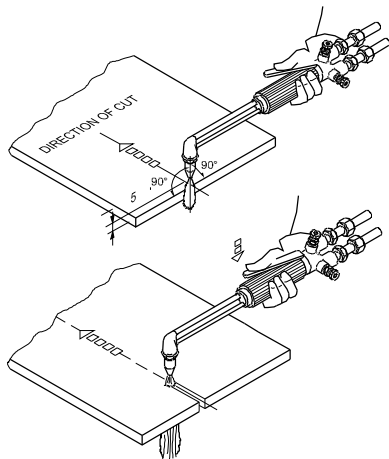


Fig 4

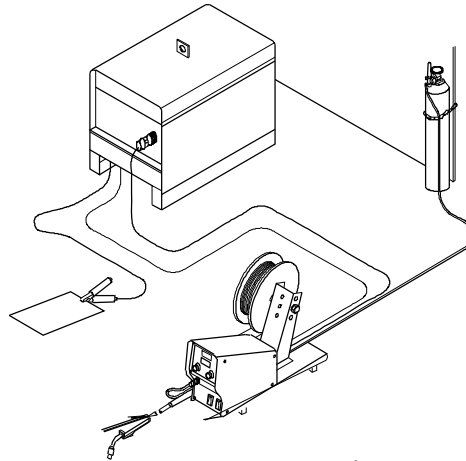


Fig 5

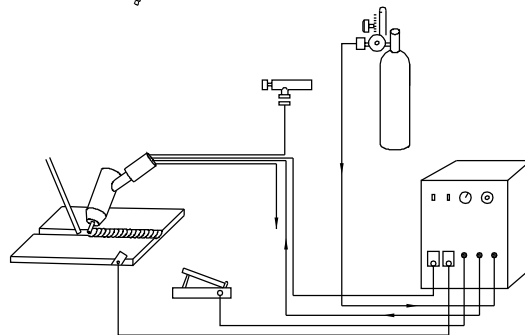
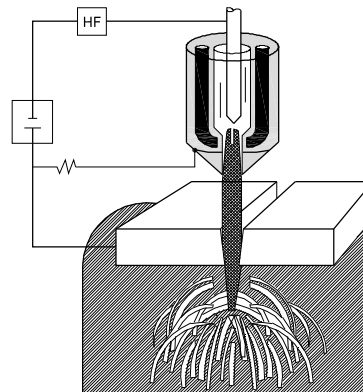


Fig 6



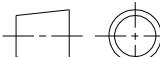
1	-	-	-	-	-	1.1.01
NO.OFF	STOCK SIZE	SEMI-PRODUCT	MATERIAL	PROJECT NO.	PART NO.	EX. NO.
SCALE 1:1	<b>DEMONSTRATION OF MACHINERY USED IN WELDING TRADE</b>				DEVIATIONS ±1.00	TIME 6hrs
					CODE NO. WLN1101E1	

Fig 7

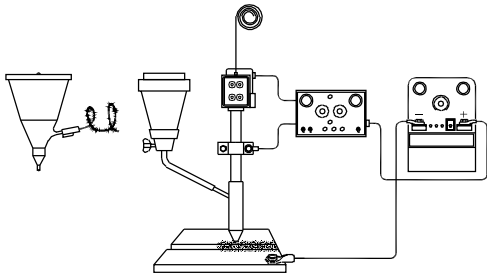


Fig 8

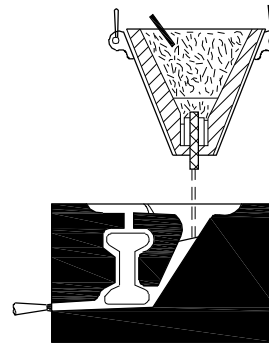


Fig 9

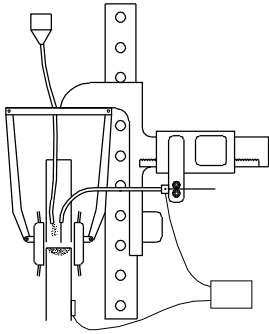


Fig 10

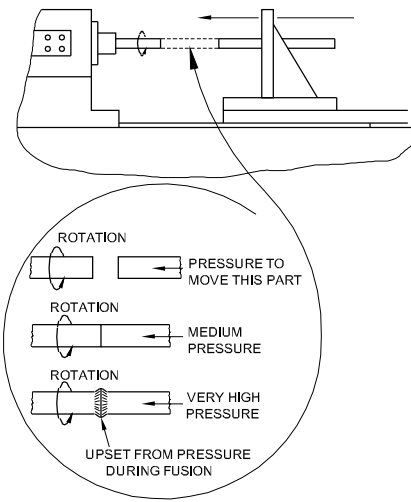


Fig 11

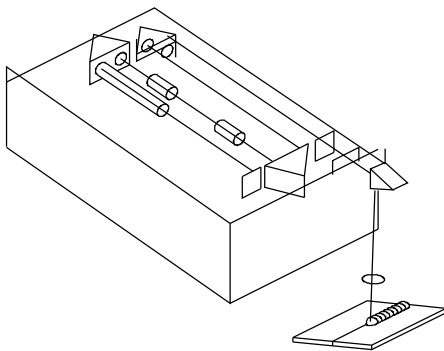


Fig 12

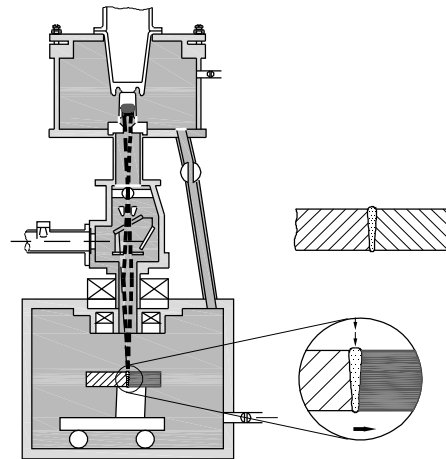
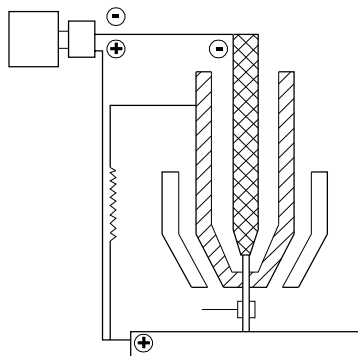


Fig 13



1	-	-	-	-	-	1.1.01
NO.OFF	STOCK SIZE	SEMI-PRODUCT	MATERIAL	PROJECT NO.	PART NO.	EX. NO.
SCALE 1:1	<b>IDENTIFICATION OF MACHINERY USED IN WELDING TRADE</b>				DEVIATIONS ±1.00	TIME 6hrs
					CODE NO. WLN1101E2	



Fig 14

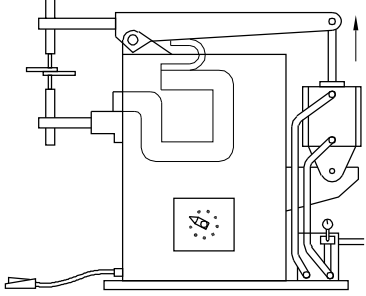


Fig 15

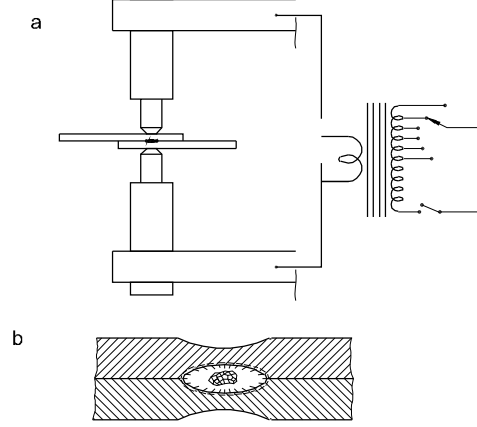


Fig 16

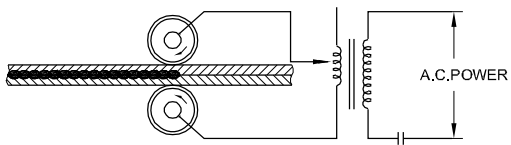


Fig 17

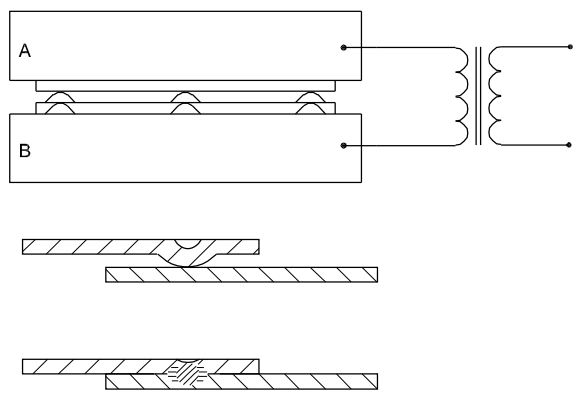


Fig 18

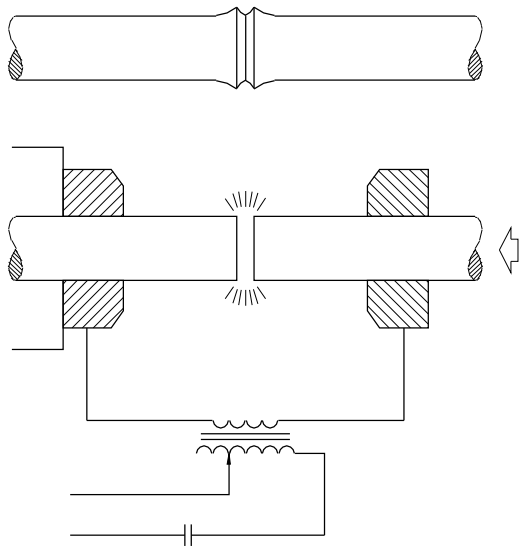
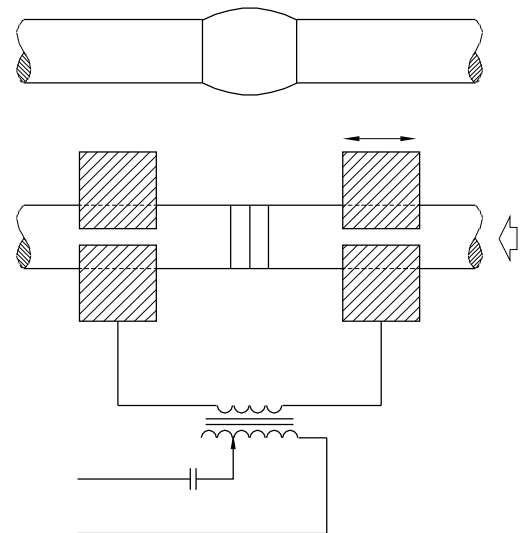


Fig 19



1	-	-	-	-	-	1.1.01	
NO.OFF	STOCK SIZE	SEMI-PRODUCT	MATERIAL	PROJECT NO.	PART NO.	EX. NO.	
SCALE 1:1		<b>IDENTIFICATION OF MACHINERY USED IN WELDING TRADE</b>				DEVIATIONS ±1.00	TIME 6hrs
						CODE NO. WLN1101E2	

**TABLE 1**

Types of machine	Name of the machine	Uses
1. SMAW Ex. 1.4.01 - TP - Fig 1 - P. 92 WL1401J1 - I SEM		
2. OAW Ex. 1.2.01 - Fig 1 - P. 23 - WL 1201J1 TP - I SEM		
3. OAGC Ex. No. 1.2.02 - TT - I SEM Ex. No. 1.2.02 - P. 34 - WL 120432		
4. GMAW - 2.1.02 - TT - II SEM - TT - II SEM Ex. No. 2.1.02 - Fig 2 - P. 4 - WL 210212		
5. SMAW - TT - II SEM - P. 48 - Ex. No. 2.1.03 WL 220411		
6. PAC - TT - II SEM - P. 80 - Fig 1 Ex. No. 2.3.01 - WL 240117		
7. SAW - II SEM - TT - Ex. No. 2.4.01 - P. 82 Fig 4 - WL 230114		
8. Thermit welding - II SEM - TT - P. 85 - Fig 1 Ex. No. 2.4.01 - WL 230211		
9. Electro slag welding - II SEM - TT Ex. No. 2.4.01 - P. 86 - Fig 2 - WL 230312		
10. Friction welding - II SEM - TT - P. 88 - Fig 1 Ex. No. 2.4.01 - WL 230411		
11. Laser beam welding - II SEM - TT - P. 89 Fig 1 - Ex. No. 2.4.02 - WL 230511		
12. Electron beam welding - II SEM - TT - P. 90 Fig 2 - WL 230612		
13. Plasma arc welding - II SEM - TT - P. 92 Fig		
14. Resistance welding - II SEM - TT - P. 95 Fig 1 - WL 230811		
15. Spot welding - II SEM - TT - P. 95 Ex. No. 2.4.02 - WL 230812		
16. Seam welding - II SEM - TT - P. 96 Ex. No. 2.4.02 - WL 230816		
17. Projection welding - II SEM - TT - Fig 6 P. 97 - Ex. No. 2.4.02 - WL 230816		
18. Flash butt welding - II SEM - TT - Fig 7 Ex. No. 2.4.02 - P. 97 - WL 230817		
19. Butt on upset welding - II SEM - TT Ex. No. 2.4.02 - Fig 8 - P. 97 - WL 230818		

## Job Sequence

- Identify the machinery in your work shop.
- Name the machine and their uses.
- Record it in table 1.

**TABLE 1**

<b>S. No.</b>	<b>Name of the machine</b>	<b>Uses</b>
1		
2		
3		
4		
5		
6		
7		
8		
9		
10		
11		
12		
13		
14		
15		
16		

Get it checked by the instructor.

TABLE 1 : Referring the machine and use the machine name with help of instructor

Identification of safety equipment and their uses

Objectives: At the end of this exercise you shall be able to

- identify the safety equipment listed in the drawing
- record the uses of respective safety equipment in the table.

Fig 1

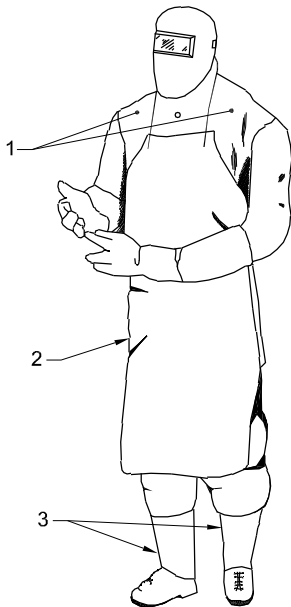


Fig 6

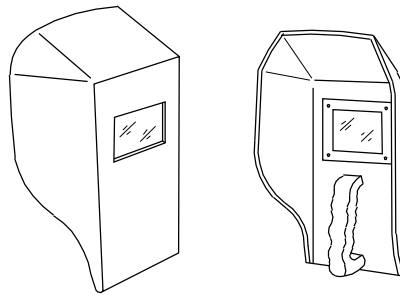


Fig 7

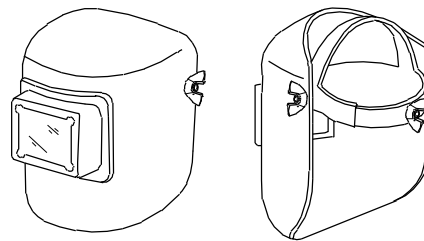


Fig 4

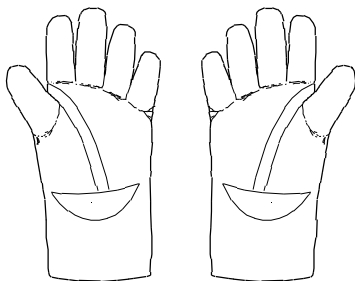


Fig 8

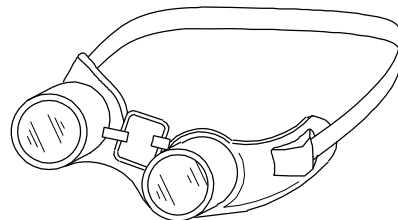


Fig 5



Fig 9



Fig 10



1	-	-	-	-	-	1.1.02
NO.OFF	STOCK SIZE	SEMI-PRODUCT	MATERIAL	PROJECT NO.	PART NO.	EX. NO.
SCALE 1:1	TITLE: <b>IDENTIFICATION OF SAFETY EQUIPMENT AND THEIR USES</b>				DEVIATIONS ±1.00	TIME 4hrs
					CODE NO. WLN1102E1	

**Note: The instructor may provide or arrange the different types of personal protection equipment or chart and explain how to identify and select the PPE devices suitable for the work and ask the trainees to write names and its uses in the given table.**

## **Job Sequence**

- Read and interpret the personal protection equipment by visually on real devices or from the charts.
- Identify and select the personal protection equipment used for suitable type of protection.
- Write the name of the PPE to the corresponding type of protection in table 1.

**TABLE 1**

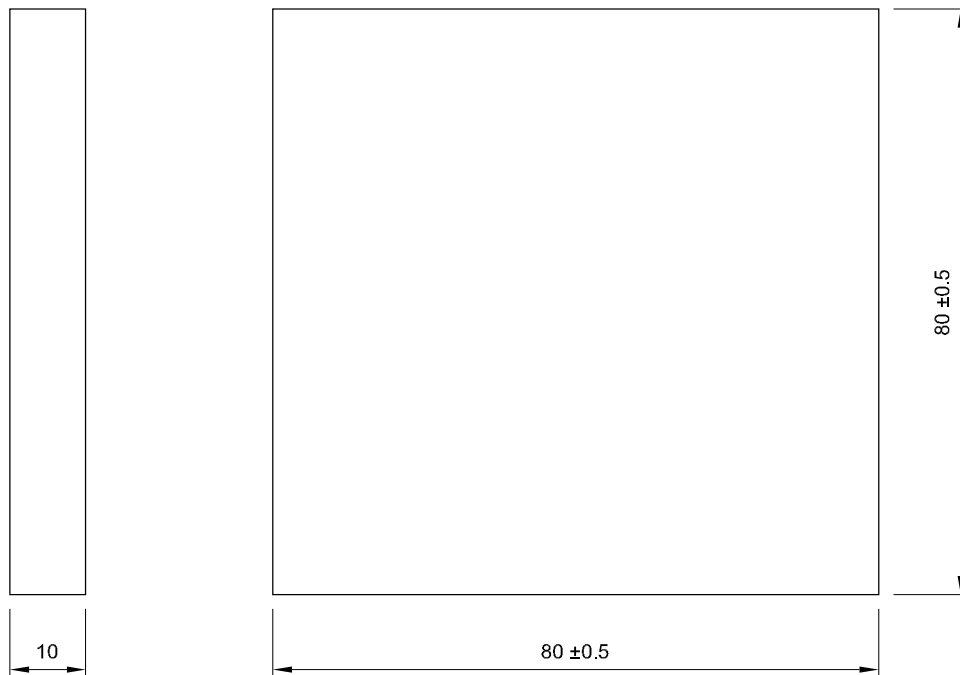
<b>S. No.</b>	<b>Name of the PPE</b>	<b>Hazards</b>	<b>Type of protection</b>
1			
2			
3			
4			
5			
6			
7			
8			
9			

Get it checked by your instructor.

**Hack sawing, filing square to dimension**

**Objectives:** At the end of this exercise you shall be able to

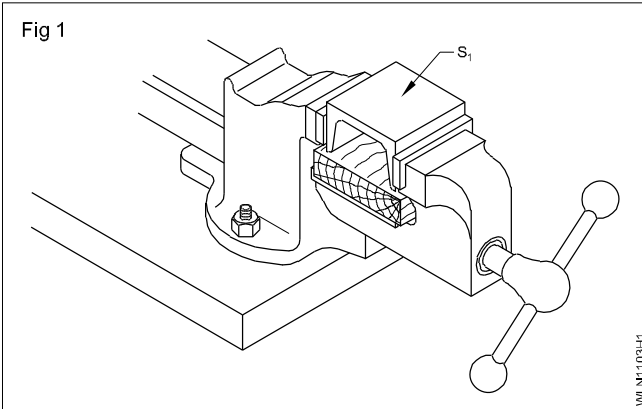
- file the surface to 90°
- mark the overall size using scribing block
- cut excess metal by hack saw
- file to square and maintain the dimension  $\pm 0.5$  mm check the dimensions with steel rule.



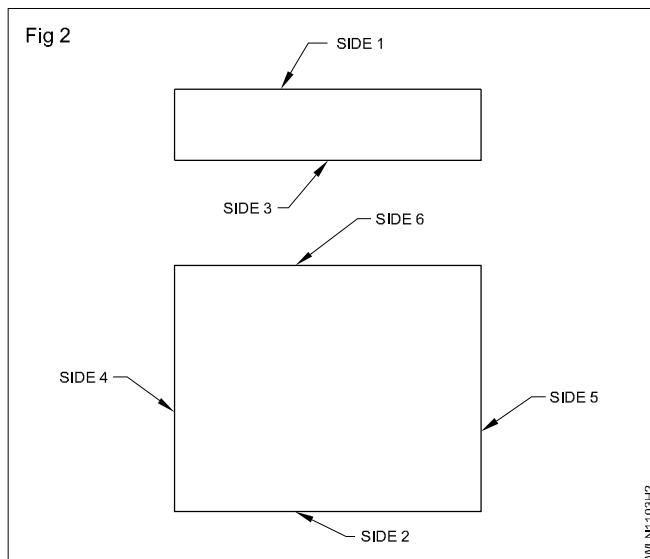
1	100ISF x 10-100	-	Fe310	-	-	1.1.03
NO.OFF	STOCK SIZE	SEMI-PRODUCT	MATERIAL	PROJECT NO.	PART NO.	EX. NO.
SCALE 1:1	<b>HACKSAWING, FILING SQUARE TO DIMENSION</b>				DEVIATIONS $\pm 0.5$	TIME 7h
					CODE NO. WLN1103E1	

## Job Sequence

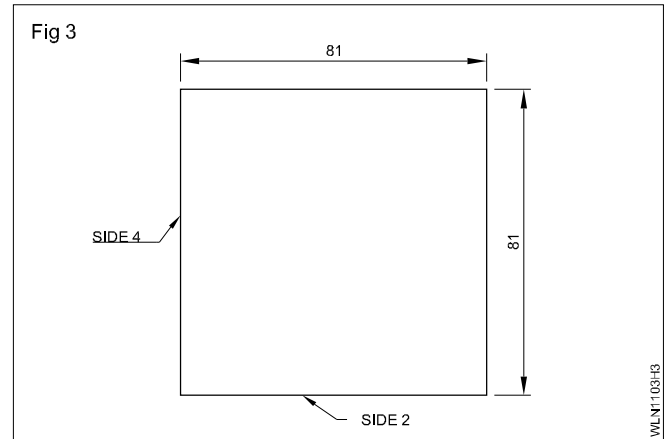
- Check the stock size material using steel rule.
- Remove burrs, if any.
- Hold the job in vice, so that surface side 1 comes on top (Fig 1).



- File the surface side 1 with a flat bastard file.
- Check the surface level with straight edge (blade of a try square).
- File one edge (side 2) flat and 90°, to side 1 (Fig 2).



- File side 3 flat and parallel to side 1.
- File side 4 to 90° to side 2.
- Check the 90° angle with try square.
- Apply marking media on side 1.
- Mark 81 mm keeping side 2 on surface plate (Fig 3).



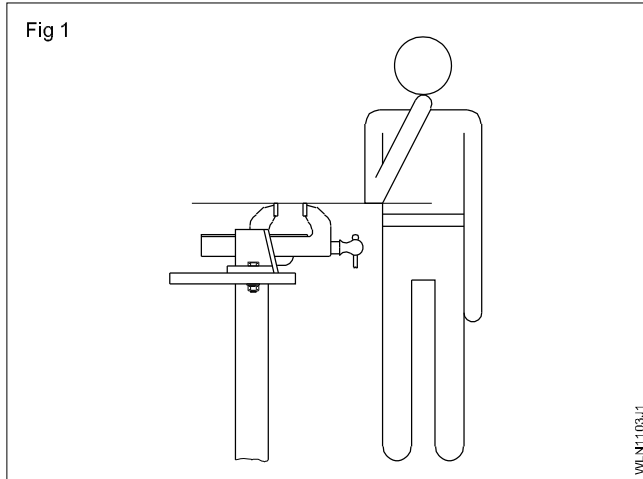
- Similarly mark 81 mm on side 5 keeping side 4 on surface plate.
- Punch the marked line.
- Hold the job in the bench-vice keeping 10 mm away from the marked line.
- Make a notch on the line to start hack sawing.
- Cut along the marked line.
- Similarly cut on the other side.
- File sides 5 and 6 and check the squares and maintain the dimension of 80.00 mm  $\pm$ 0.5 mm.
- Deburr the job and apply oil and preserve it for evaluation.

# Skill Sequence

## Filing flat surface

**Objective:** This shall be help you to  
• file flat surface

Check the height of the bench vice. (Fig 1) If the height is more, use a platform and if it less, select and use another workbench.

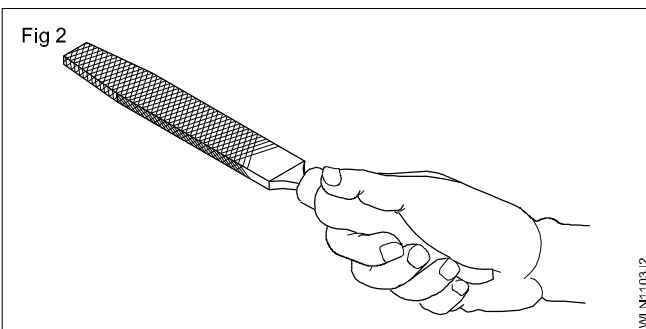


Hold the job in the bench vice with a projection of 5 to 10 mm from the top of the vice jaw.

Select the files of various grades and length according to the

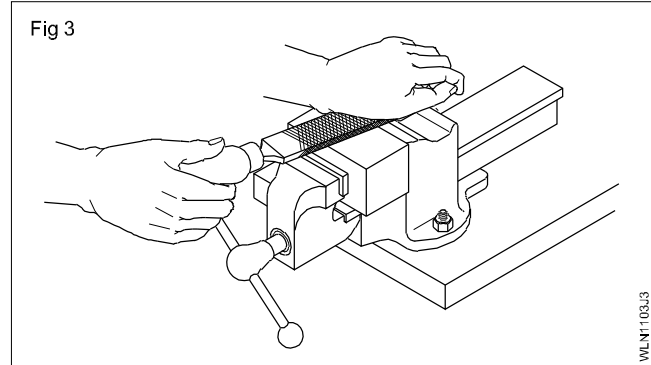
- size of the job
- quantity of metal to be removed
- material of the job.

Check whether the handle of the file fits tightly. Hold the handle of the file (Fig 2) and push the file forward using your right hand palm.

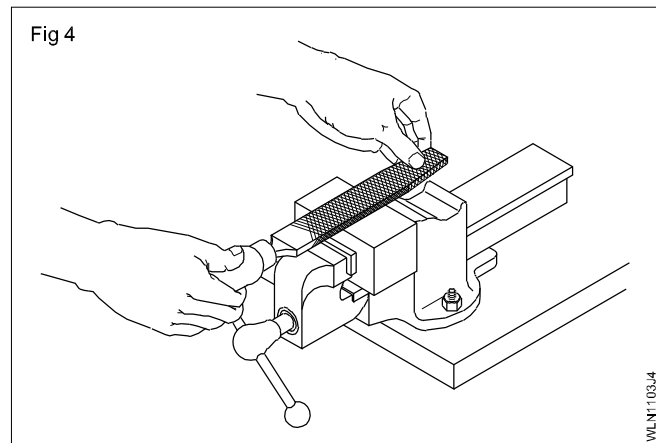


Hold the tip of the file according to the quantity of the metal to be removed.

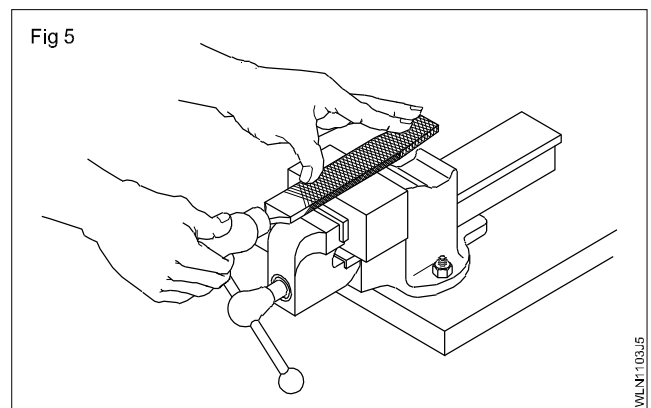
For heavy filing. (Fig 3)



For light filing. (Fig 4)

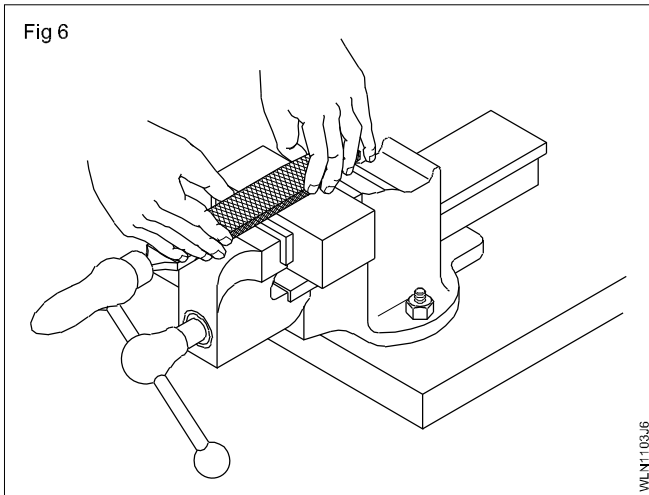


For removing local unevenness. (Fig 5)



For removing the local unevenness draw filing can also be done. (Fig 6) The same filing can also be done for fine finishing.





Start filing by pushing the file uniformly during the forward stroke and release the pressure during the return stroke.

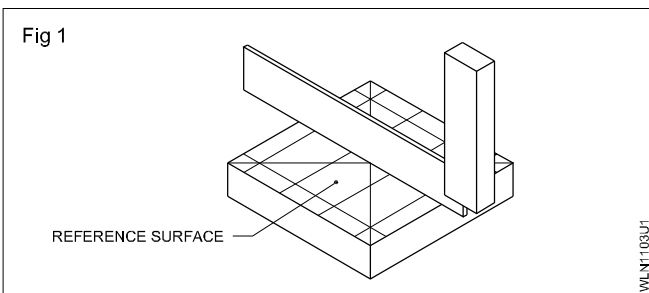
Continue giving strokes. Balance the pressure of the file in such a way that the file always remains flat and straight over the surface to be filed.

## Checking flatness and squares

**Objectives:** This shall help you to

- check flatness
- check squares.

### Checking flatness (Fig 1)



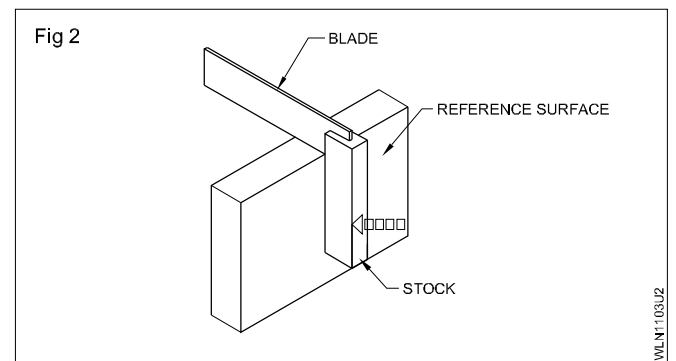
Use the blade of the try square as a straight edge for checking flatness.

Place the blade of the try square on the surface to be checked in all directions so as to cover the entire surface.

Do the checking facing the light. Light gap will indicate high and low spots.

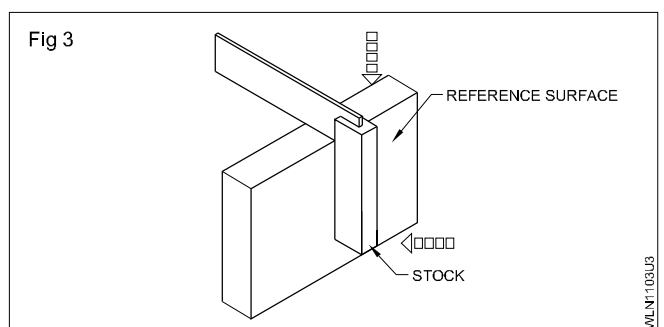
**Checking squares:** Consider the large finished surface as the reference surface. Ensure that the reference surface is filed perfectly and is free from burrs.

Butt and press the stock against the reference surface. (Fig 2)



Bring down slowly (Fig 3) and make the blade touch the second surface with which the squares is to be checked.

Light gap will indicate the high and low spots.



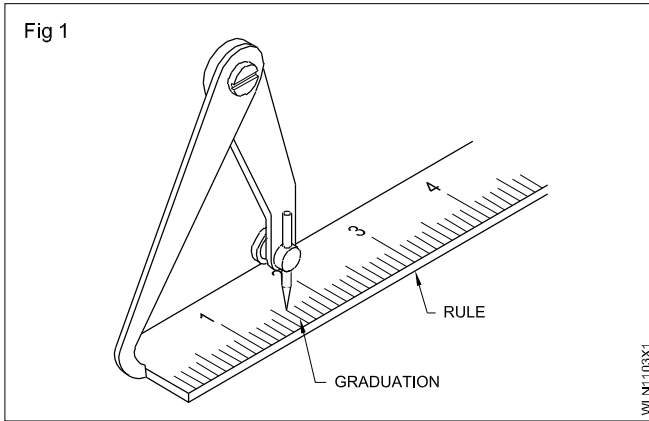
## Marking lines parallel to the edge of the job

**Objective:** This shall help you to

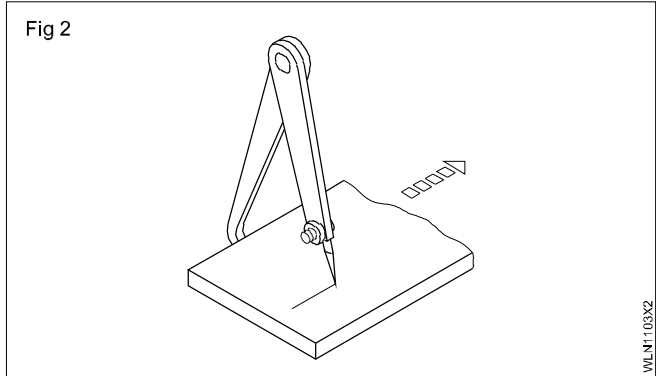
- mark parallel lines using a jenny caliper.

Apply marking medium on the surface to be marked.

Set the jenny caliper to the size to be marked (i.e. dimension) with the help of a steel rule. (Fig 1)



Transfer the set dimension to the job. (Fig 2)



Incline slightly and move the jenny caliper with uniform speed and mark lines.

Make witness marks on the lines marked using a 60° prick punch. The witness marks should not be too close to one another.

## Marking parallel lines using surface gauge

**Objective:** This shall help you to

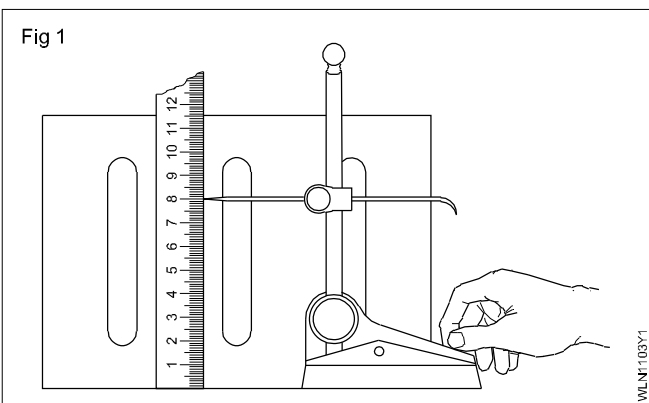
- mark parallel lines using a surface gauge.

Check the free movement of the scriber and other sliding units.

Clean the base of the surface gauge.

Keep the base firmly on the surface plate.

Rest the steel rule against the angle plate and set the scriber to the size to be marked. (Fig 1)

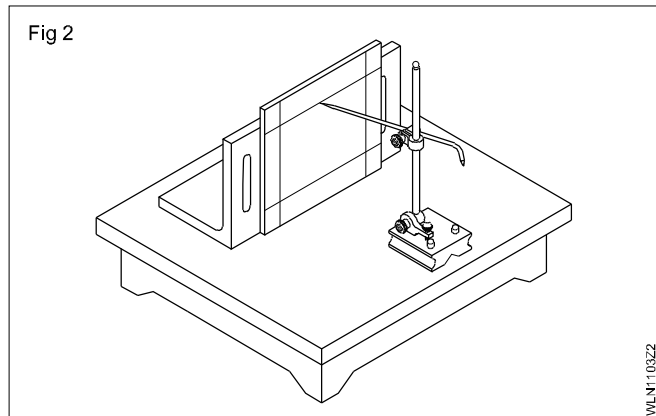


Make sure that the job has no burrs and has been properly cleaned.

Apply a thin and even coating of the marking media.

Butt the job against the angle plate.

Hold the job in one hand and move the scriber point touching the surface across the work and mark. (Fig 2)



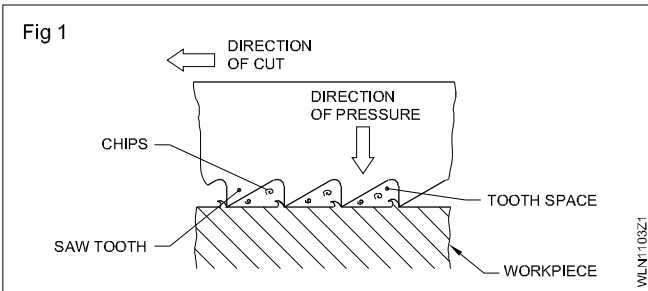
# Hacksawing

**Objectives:** This shall help you to

- fix hacksaw blades maintaining correct tension and direction
- cut metal pieces with a hacksaw.

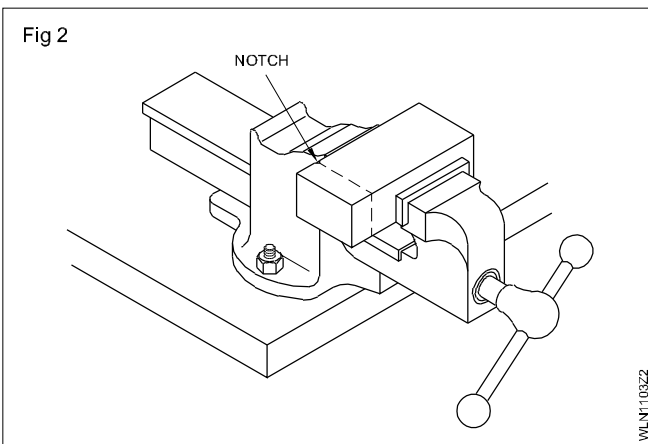
Insert the hacksaw blade pin holes in the blade holder pins (fixed and adjustable) of the hacksaw frame.

Ensure that the teeth of the hacksaw blade is pointed in the direction of the cut and away from the handle. (Fig 1)



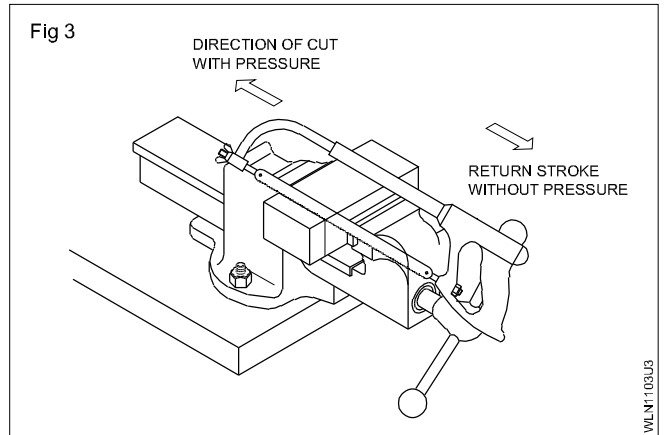
Ensure that the blade is held vertical and correctly tensioned before starting.

While starting the cut, make a small notch. (Fig 2)



The cutting movement should be steady, and the full length of the blade must be used.

Apply pressure only during the forward stroke. (Fig 3)



While cutting, make sure that at least two to three teeth are in contact with the work.

Normally, a coolant is not necessary while hacksawing.

**Do not move the blade too fast. While finishing a cut slow down to avoid breakage of blade or injury to yourself and others.**

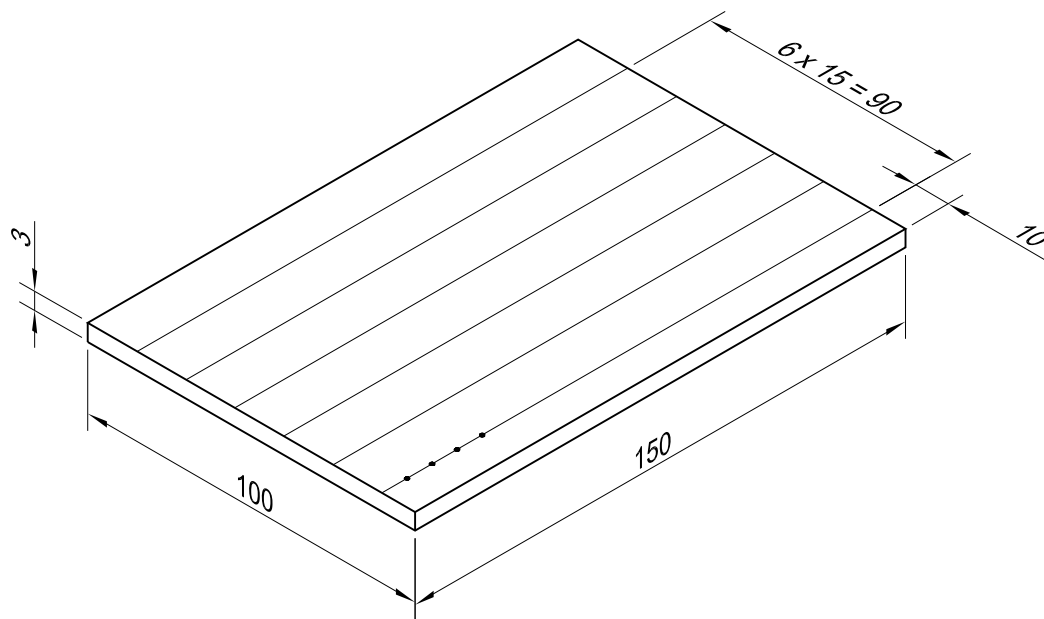


Scan the QR Code to view the video for this exercise

**Marking out on MS plate and punching**

**Objectives:** At the end of this exercise you shall be able to

- draw lines on metallic surfaces by scribers
- draw parallel lines by jenny calipers
- draw parallel lines with a surface gauge
- draw angles with a simple protractor and scriber
- bisect the angles with a divider
- draw circles, arcs and tangents with divider and scriber
- register the profile by dot punching.

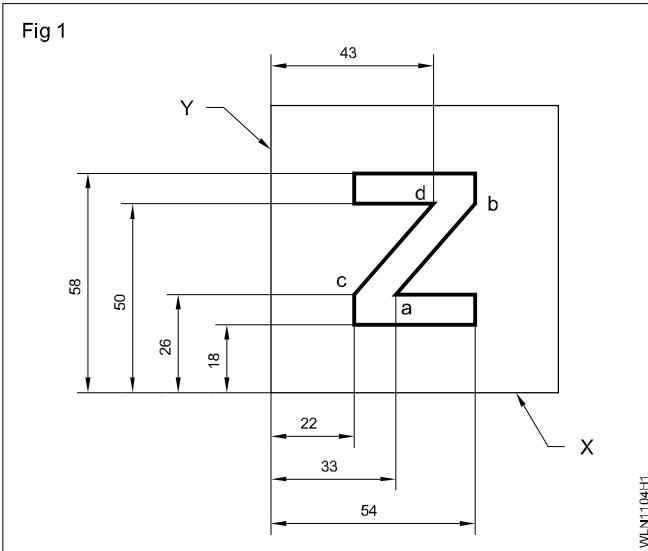


1	100 ISF 3x150x100mm	-	Fe 310	-	-	1.1.04
NO.OFF	STOCK SIZE	SEMI PRODUCT	MATERIAL	PROJECT NO.	PART NO.	EX. NO.
SCALE NTS	<b>MARKING OUT ON M.S. PLATE AND PUNCHING</b>				TOLERANCE ±1	TIME 8hrs
					CODE NO. WLN1104E1	

# Job Sequence

## Marking 1

- Check the raw material for its size and its squares.
- Apply copper sulphate solution on one side of the job and allow it to dry.
- Scribe parallel lines to the edges 'x' and 'y' using a jenny caliper. (Fig 1)

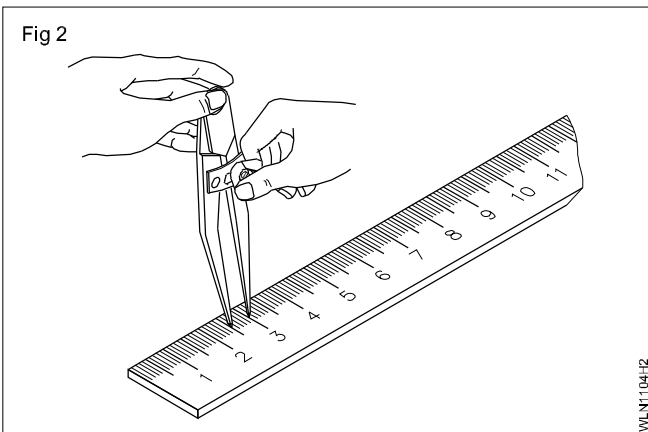


**To avoid confusion, do not scribe the line longer than necessary.**

- Scribe two lines by joining points ab and cd, using a steel rule and scriber.
- Punch witness marks and complete 'Z'.

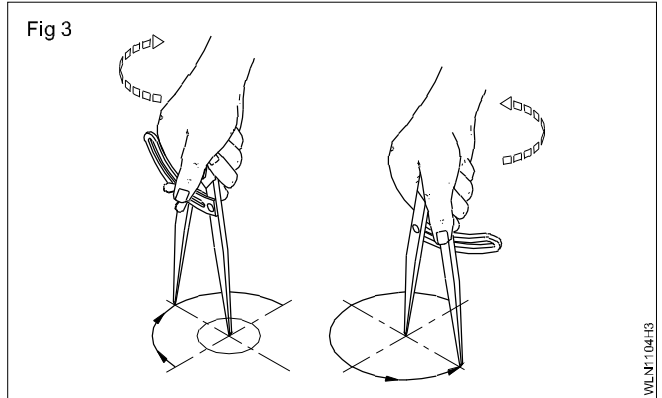
## Marking 2

- Apply the marking medium on the other side of the job and allow it to dry.
- Mark the center lines of three circles and one semicircle using the jenny caliper.
- Punch all the four centers using a 30° prick punch. (Fig 4)
- Open and set the divider to 5 mm. (Fig 2)



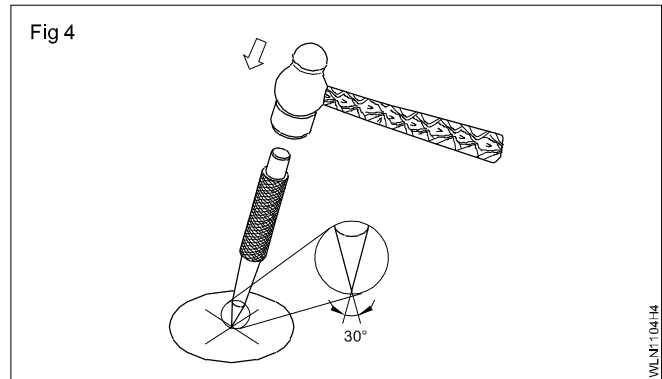
**Make sure that both the legs of the divider are of equal length.**

- Draw two circles of  $\varnothing 10$  using the divider. (Fig 3)



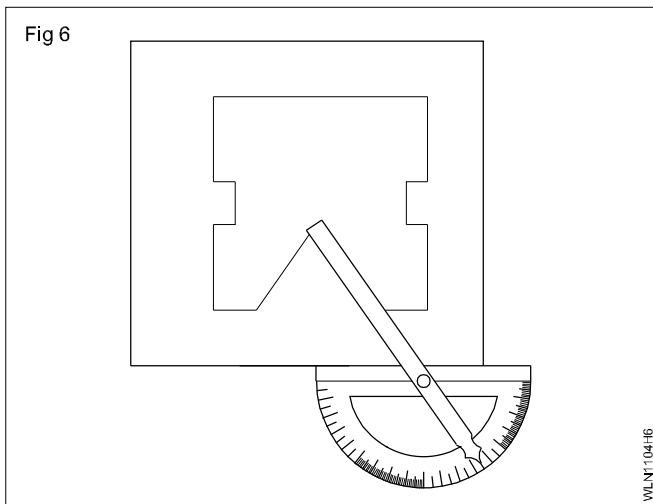
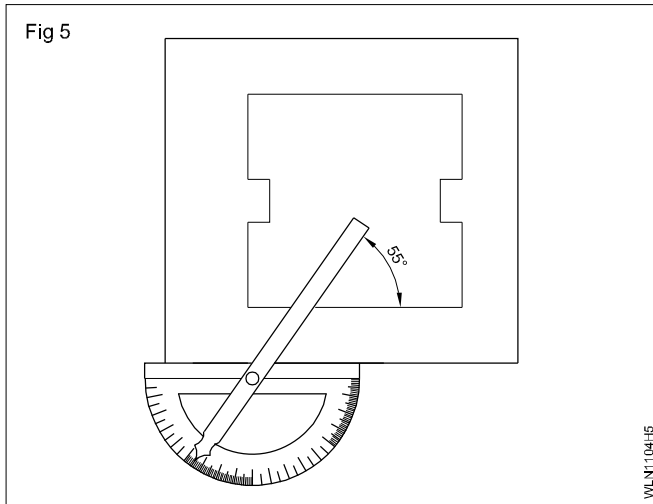
- Set and draw  $\varnothing 12$  circle and R35 semicircle.
- Punch witness marks on the circles and semicircles. Show the markings on both the sides to the instructor for evaluation.

**Reuse the same material for marking 3 and 4.**

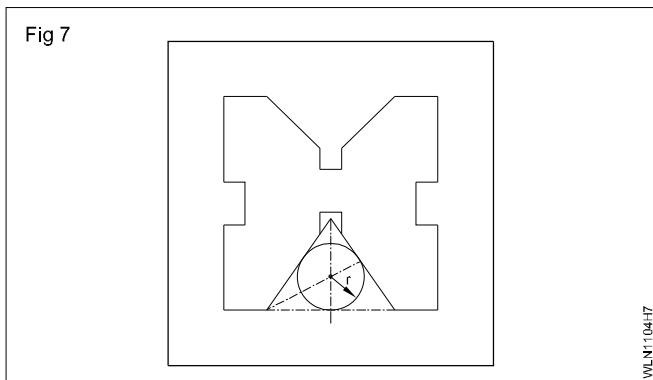


## Marking 3

- File and finish one of the marked surfaces flat and de-burr.
- Apply copper sulphate solution on the finished side.
- Butt the job against the angle plate.
- Mark all the parallel lines to the edges using the surface gauge.
- Also mark the starting points of the V grooves.
- Set and lock the bevel protractor at 55°.
- Butt the bevel protractor on to the edge of the job and mark one side of the V groove. (Figs 5 & 6)
- Continue the same procedure and complete the 44° V groove.
- Complete the V block marking.



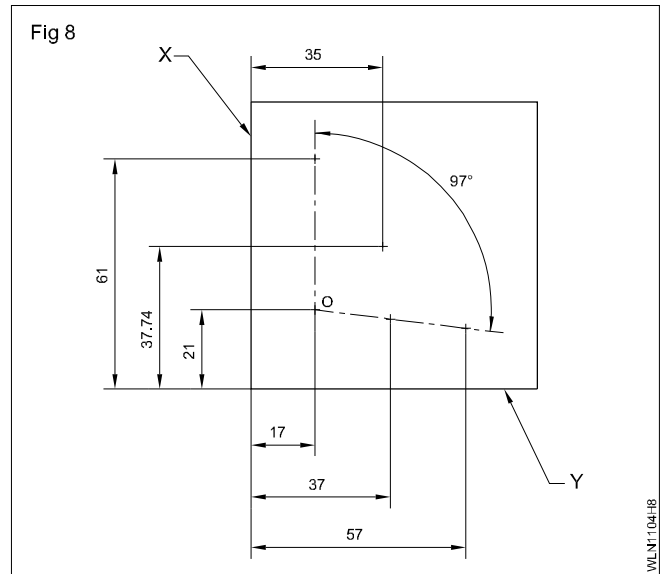
- Bisect any two sides of the triangle formed by the 55° V groove, and get the center and radius of the circle.
- Draw the circle on the 55° V groove. (Fig 7)



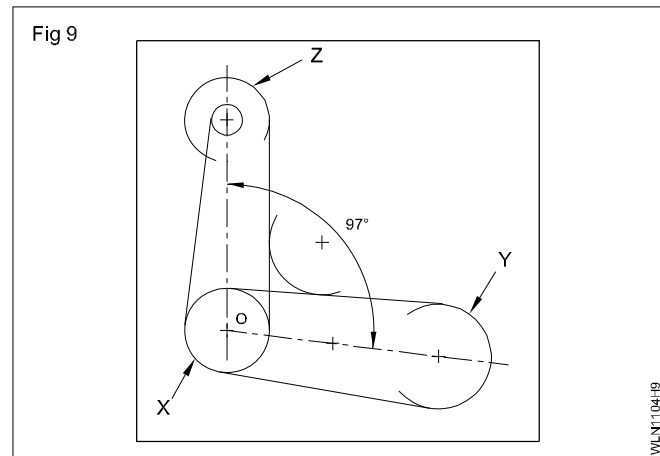
- Similarly draw the circle on the 44° V groove.
- Punch witness marks.

#### Marking 4

- File and finish the other surface flat, deburr and apply the marking medium.
- Scribe the center lines and parallel lines to the edges 'x' and 'y'. (Fig 8).



- Set 97° on the bevel protractor.
- Mark 97° line through point 'O' and get the centers of the other two circles. (Fig 9)

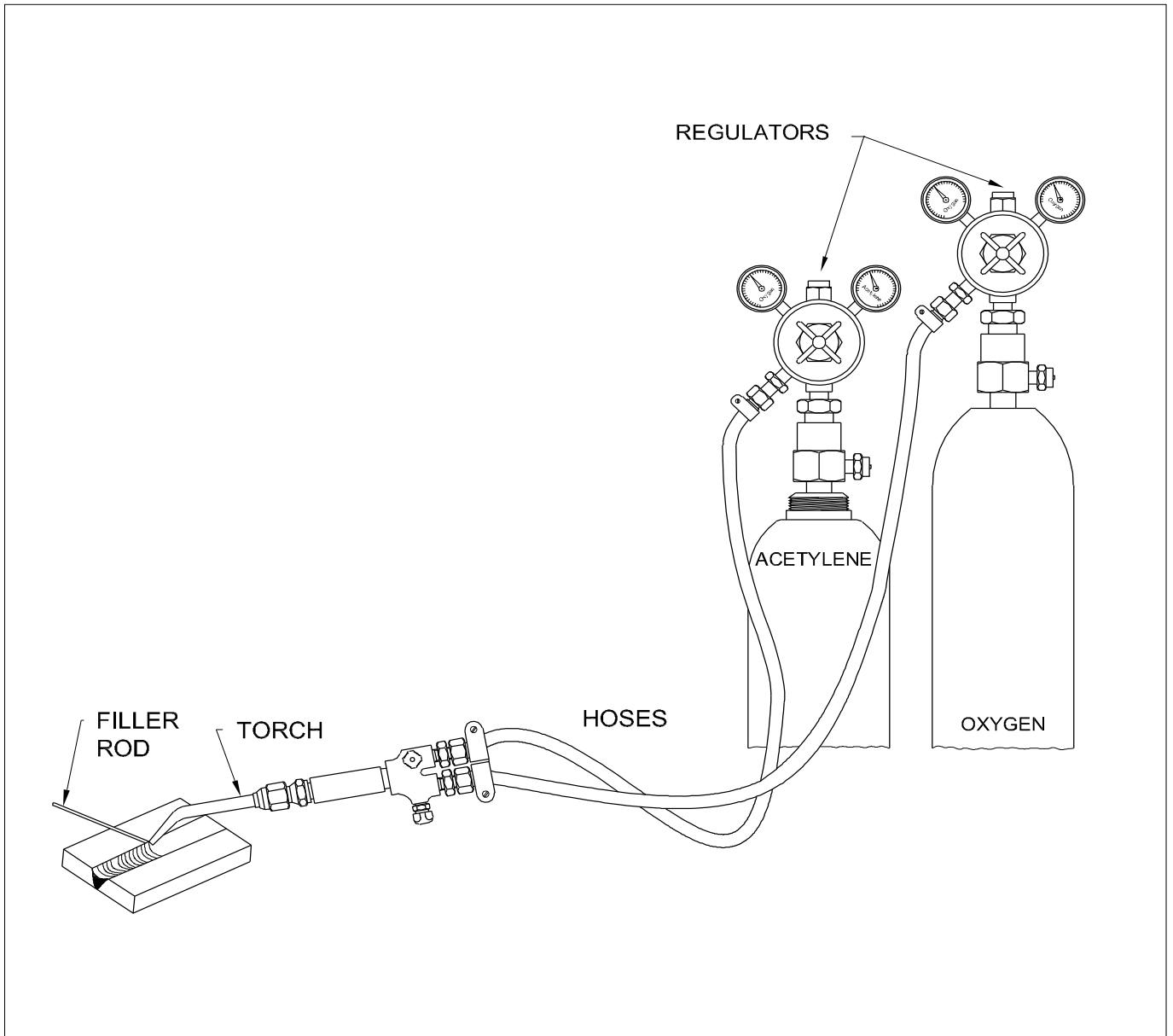


- Punch center marks on all the four circles.
- Draw all the four circles using a divider.
- Draw R8, R8 and R10 curves a little more than the length required.
- Draw the tangents close to the edges of the 'x' and 'y' & 'z' circles using a steel rule and scribe. (Fig 9)
- Punch witness marks.

**Setting of oxy-acetylene welding**

**Objectives:** At the end of this exercise you shall be able to

- setup the oxy-acetylene gas welding plant by connecting all components
- test for gas leakages at all connections
- set the required gas pressure on the regulators
- set natural oxidizing and carburizing flames
- close down the oxy-acetylene gas welding plant maintaining correct sequence.



1	-	-	-	-	-	1.1.05
NO.OFF	STOCK SIZE	SEMI-PRODUCT	MATERIAL	PROJECT NO.	PART NO.	EX. NO.
SCALE 1:1					DEVIATIONS ±0.5	
<b>SETTING OF OXY-ACETYLENE WELDING</b>					TIME 2h	
					CODE NO. WLN1105E1	

## Job Sequence

- Inspect all inlet and outlet valves, threads and seats on both cylinders and regulators.
- Crack the valves.
- Install the regulator.
- Inspect hose fittings for damage and attach it.
- Open the gas cylinders, oxygen and Acetylene.
- Purge both hoses by opening the regulator valve correctly as per gas, one at a time.
- Inspect torch handle.
- Assemble the torch handle.
- Attach the hose correctly.
- Leak check and purging.
- Light the flame.
- Adjust the flame to get neutral flame.
- Observe the flame pattern.
- Adjust the flame to get oxidizing flame.
- Observe the flame pattern.
- Adjust the flame to get carburizing flame.
- Observe the flame pattern.
- Shut down the torch flame.
- Shut down and bleed the pressure from the system.

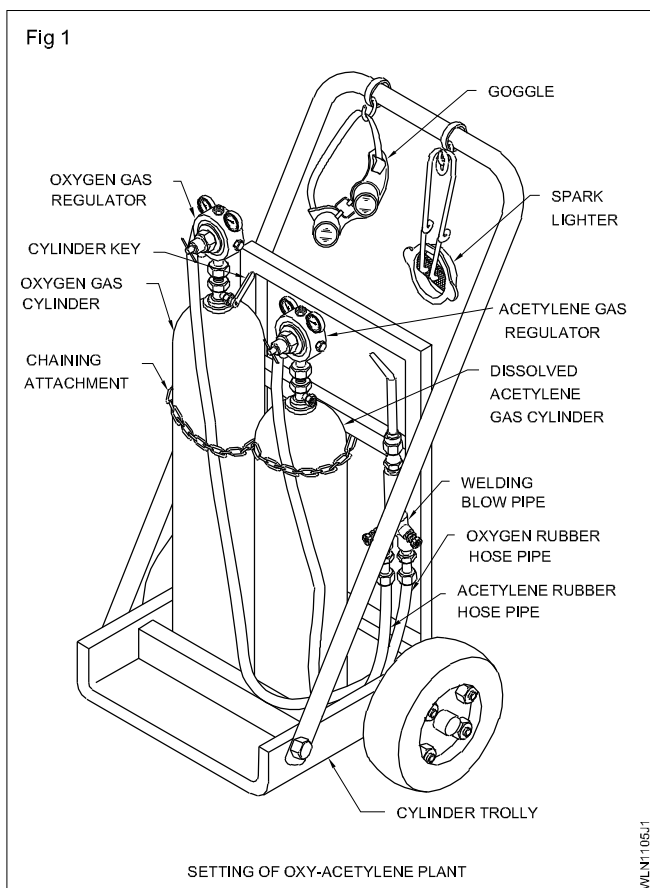
## Skill Sequence

### Setting of oxy-acetylene welding equipment, lighting and setting of flame

**Objectives:** This shall help you to

- set up oxy-acetylene plant
- set up the flames neutral oxidizing and carburizing
- close down the gas welding plans.

#### Setting up oxy-acetylene plant Fig 1



Move oxygen and acetylene cylinders with the caps from the store to the gas welding area.

**An oxygen cylinder is identified by the black color painted on it. An acetylene cylinder is identified by the maroon color painted on it. Also the oxygen cylinder will be taller than an acetylene cylinder and the diameter of oxygen cylinder will be less than the diameter of an acetylene cylinder.**

Ensure full cylinders are kept separately from the empty cylinders.

Position the gas cylinders in a trolley and secure them with a chain.

Always keep the cylinders upright/vertically in the cylinder stand/on the floor. (Fig 2)

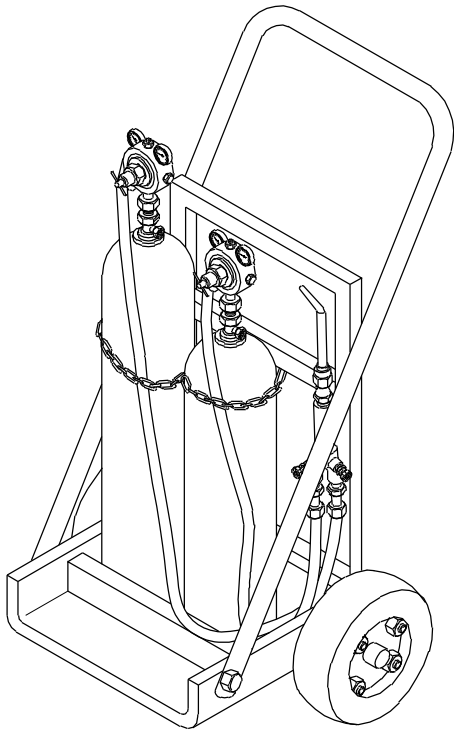
While moving, the gas cylinders should be kept slightly inclined to the vertical position and the protector cap used to avoid damage to the cylinder valves. (Fig 3)

**Do not roll the cylinders horizontally on the ground.**

Remove the cylinder caps. Crack the gas cylinder valves by quickly opening and closing them using the cylinder key. Fig 4.



Fig 2

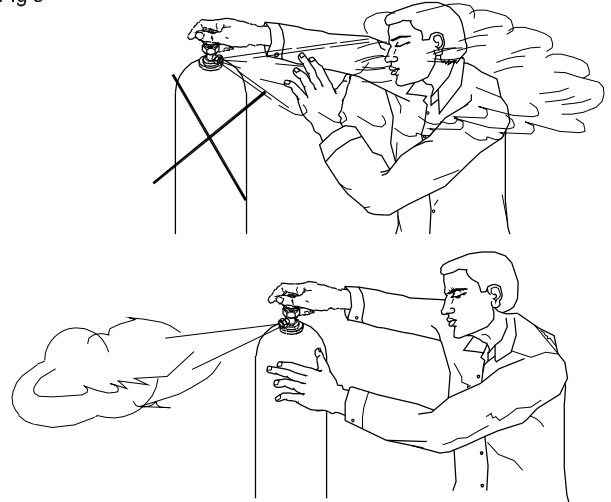


WLN1105J2

and also to prevent the dust particles from entering into the regulators which may cause damage to the regulators.

Always stand opposite to the valve outlet while cracking the cylinders. (Fig 5)

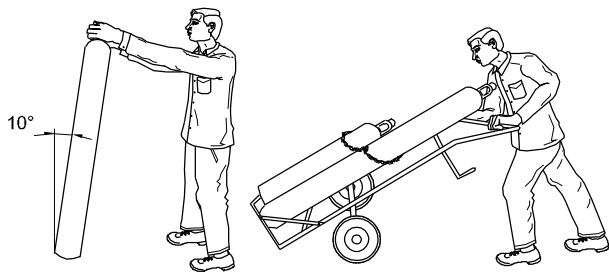
Fig 5



WLN1105J5

Ensure that your hands are free from grease or oil.

Fig 3



WLN1105J3

Connect the oxygen regulator to the oxygen gas cylinder (right hand threads).

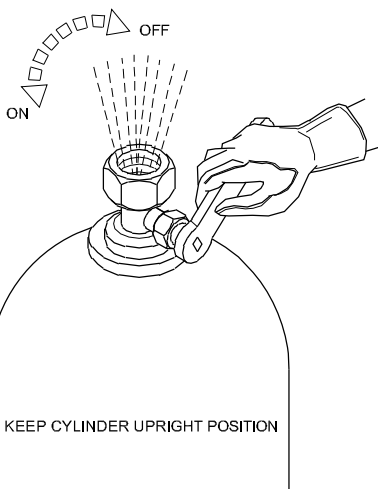
Connect the acetylene regulator to the acetylene gas cylinder (left hand threads).

**Ensure the pressure adjusting screws of both regulators are in a released condition.**

Connect the correct regulator on cylinders. Acetylene connections have left hand thread and oxygen has right hand thread.

Fig 4

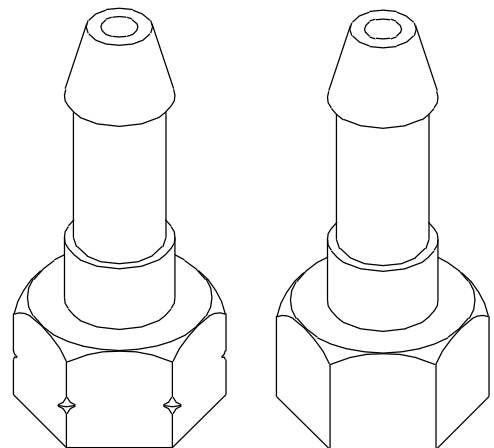
BLOW OUT THE CYLINDER VALVE SOCKET BEFORE CONNECTING THE REGULATOR CRACKING OPEN THE CYLINDER VALVE MOMENTARILY



WLN1105J4

**The acetylene regulator connecting nut will have a groove cut on it (Fig 6) and the pressure gauge dial will be of maroon color.**

Fig 6



LEFT HAND ACETYLENE

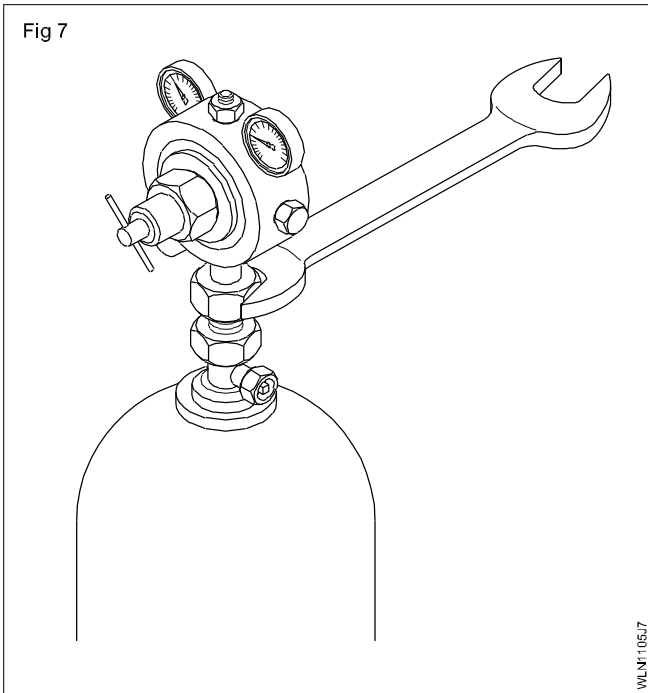
RIGHT HAND OXYGEN

WLN1105J6

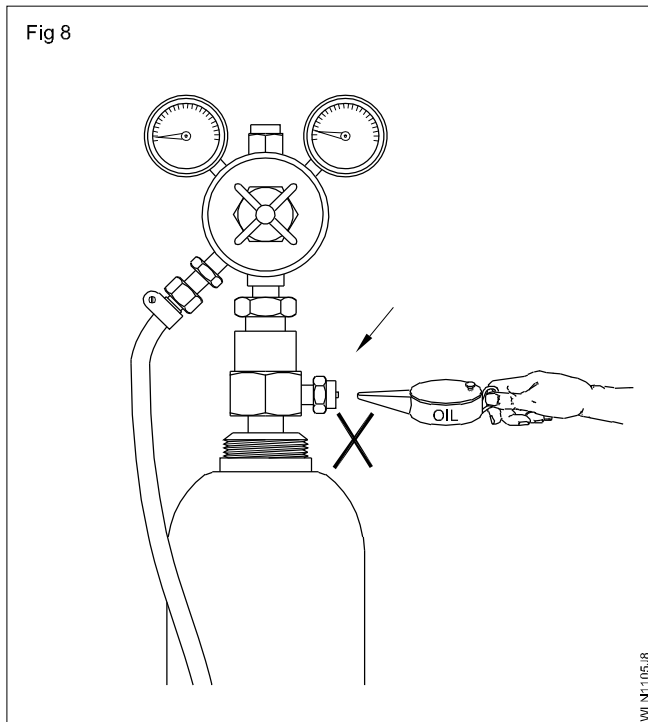
Dirt and dust particles from the cylinder valve sockets are cleaned by cracking the cylinder valve. This will avoid leakage of gas due to improper seating of the cylinder valve

All threaded connections should be fixed initially by tightening by hands and then only a spanner should be used. This will help to avoid assembly with cross thread leading to damage to threads.

Always use the correct size spanner to prevent damage to the threads. (Fig 7)



**It is dangerous to apply lubricants in the threaded assemblies of gas welding equipment as it can cause fire. (Fig 8)**



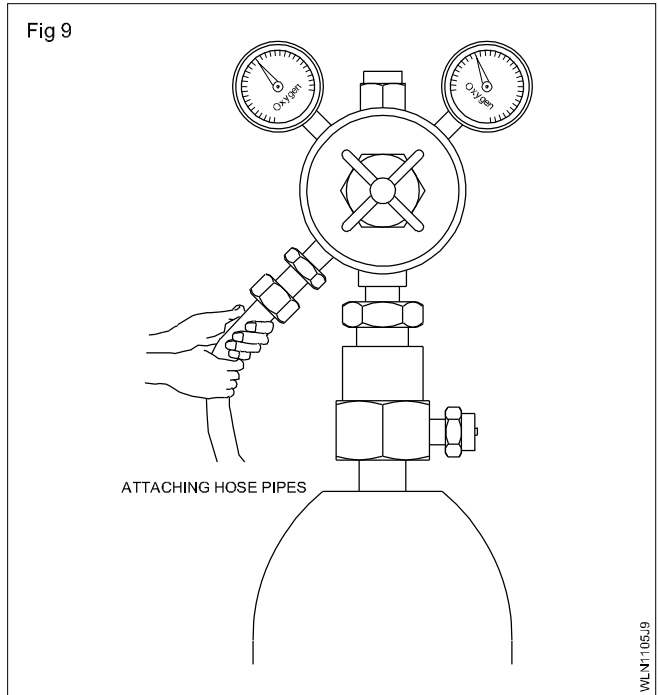
While tightening avoid undue force. The connections should be just tight.

Connect the hose connector at the regulator end and the hose-protectors at the blowpipe end.

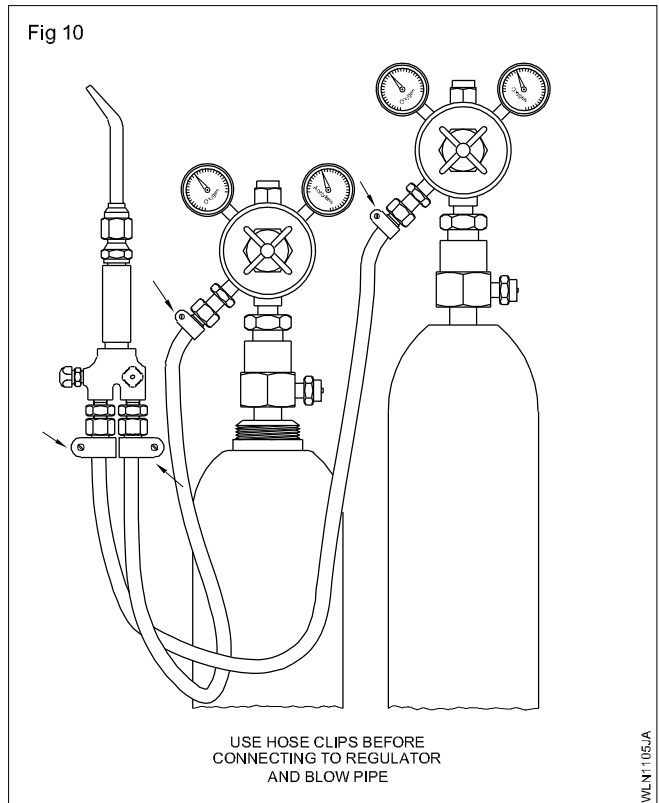
(Use black hose for oxygen line and maroon hose for acetylene line.)

**Acetylene connections have left hand threads with a cut on the corners of the nut while oxygen connections have right hand thread without a cut.**

Attach one end of the black hose-pipe to the oxygen regulator outlet and the maroon colored hose-pipe to the acetylene regulator outlet. (Fig 9)

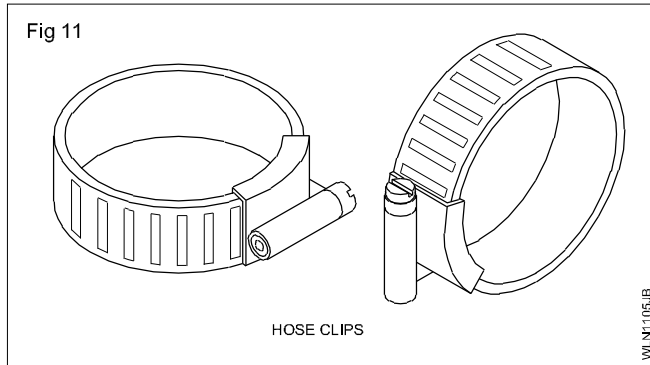


Secure the joints using hose-clips to ensure good grip and to avoid gas leakage. (Fig 10)

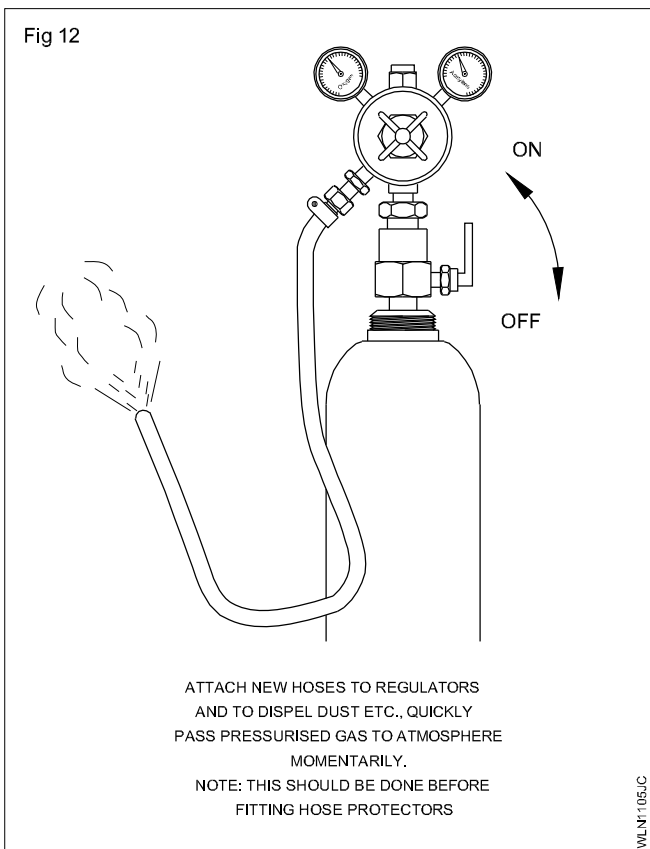


Use a screwdriver to tighten the hose-clips.

Always use the correct size hose-clips. (Fig 11)



Turn on the pressure adjusting screw of the regulator to which the oxygen hose pipe is connected. (Fig 12)



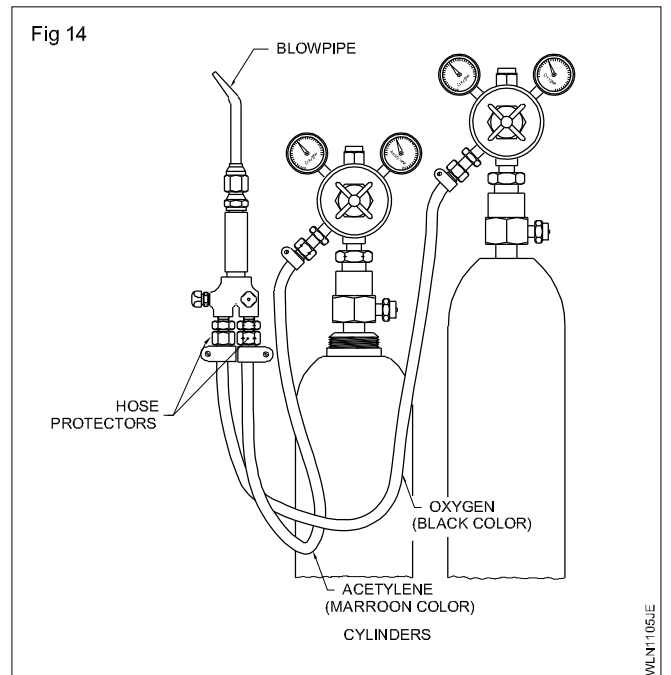
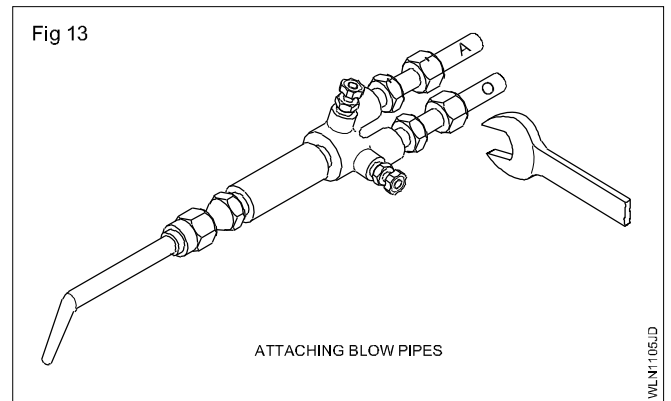
Exert sufficient pressure to blow out dust or dirt particles if any are tapped inside the hose-pipe and then release the pressure adjusting screw.

Repeat the same for the acetylene hose also.

### Attaching blowpipe

The other end of the hose-pipe is to be attached to the blowpipe inlets. (Fig 13)

Fix the hose-protectors at the blowpipe ends. The hose-protectors with a groove at the corners are fixed on the acetylene hose-pipe and connected to the acetylene inlet of the blowpipe. The hose-protectors without cutting marks are fixed on the oxygen hose-pipe and connected to the oxygen inlet of the blowpipe. (Fig 14)



The hose-protectors protect against the return flow of gas from the blowpipe to the rubber hoses. They act as non-return valves.

### Adjusting the gas pressure

The gas pressure for both oxygen and acetylene has to be adjusted at regulators according to the size of the nozzle. The size of the nozzle is selected according to the job material and thickness.

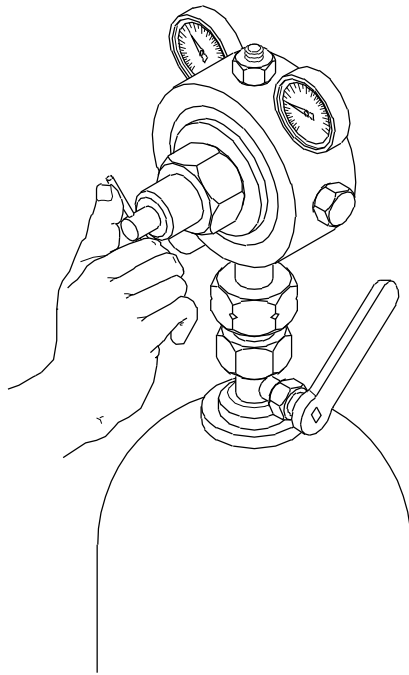
For adjusting the gas pressure, open the valves of both the cylinders slowly by one turn and set the pressure on both regulators as 0.15 kg/cm<sup>2</sup> for small size nozzles, by tightening the pressure adjusting screws. (Fig 15) Ensure the blow pipe control valves are kept open while setting the gas pressure.

The pressure can be read on the working pressure gauge of gas regulators.

### Testing for leakage

All connections must be tested for leakage.

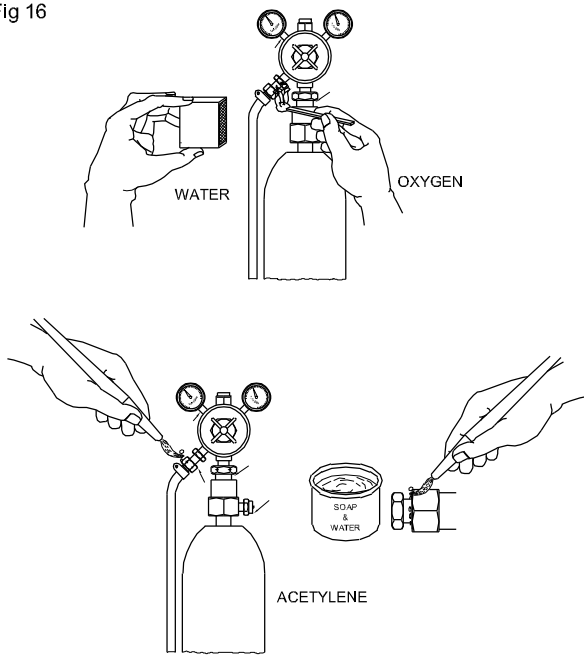
Fig 15



WLN1105JF

Apply soap water solution for acetylene connections and fresh water for oxygen connections. (Fig 16)

Fig 16



WLN1105JG

Use of soap water on oxygen connections may lead to fire hazards.

Never use matches or flame light during leakage test.

### Lighting the flame

Attach the recommended size of nozzle to the neck of the welding blowpipe i.e. nozzle No. 3.

Open the gas cylinders and adjust the recommended gas pressures on the regulators.

The pressure of oxygen and acetylene is 0.15 kgs/cm<sup>2</sup> for nozzle No. 3.

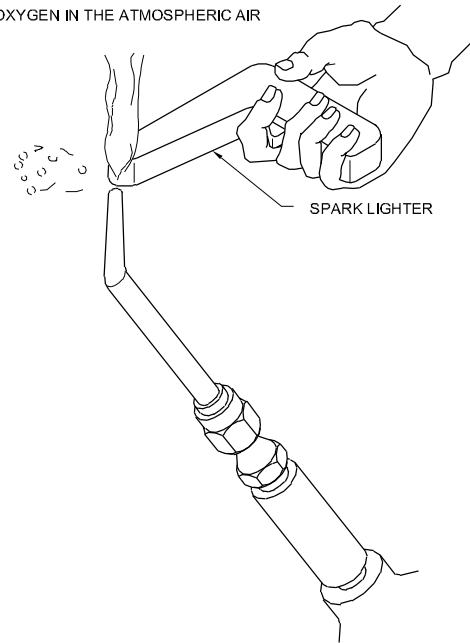
Open cylinder valves very slowly.

While setting pressure on the regulator, keep the blowpipe control valve open for accurate setting.

Open the acetylene control valve 1/4 turn on the blowpipe and ignite with a spark lighter. (Fig 17) Acetylene burns using the oxygen in the atmospheric air with a black smoke.

Fig 17

ACETYLENE BURNS USING OXYGEN IN THE ATMOSPHERIC AIR



WLN1105JH

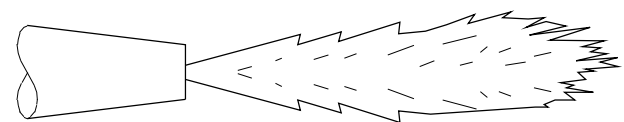
Avoid using any other source of fire other than the spark lighter.

Point the blowpipe in a safe direction in the open space, away from you and others.

Increase the acetylene till the black smoke disappears. (Fig 18)

Fig 18

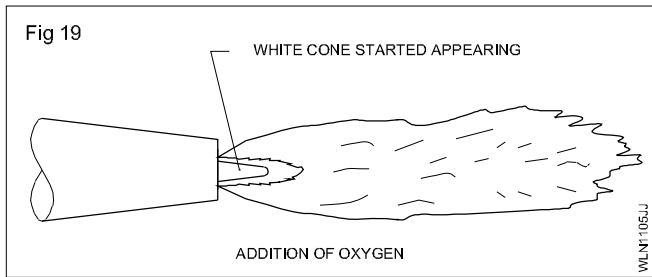
NO WHITE CONE



ACETYLENE FLAME IN ATMOSPHERIC AIR

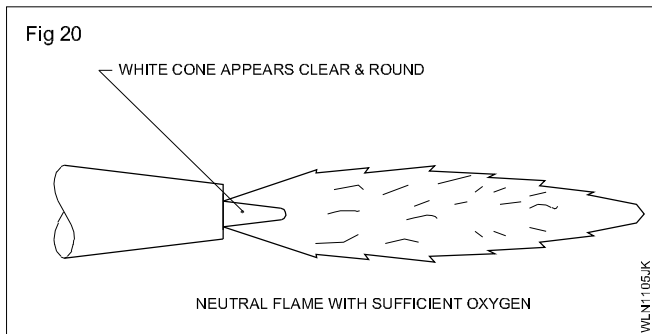
WLN1105JI

Observe the flame and add oxygen by opening the oxygen control valve of the blowpipe. Now a bright white cone starts appearing at the tip of the nozzle. (Fig 19)



### Flame adjusting to set different types of oxy-acetylene flames.

To adjust the neutral flame, add sufficient oxygen to make the white cone clear and round. (Fig 20)

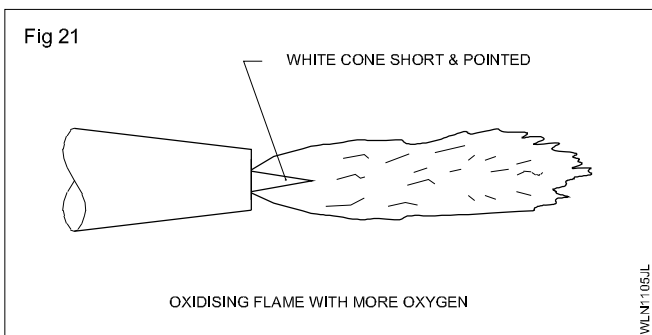


The gas mixture from the blowpipe has equal volume of oxygen and acetylene.

To adjust the oxidizing flame, from neutral flame decrease acetylene flow.

The white cone will become short and sharp.

The flame will produce a hissing sound and will have a short length. (Fig 21)



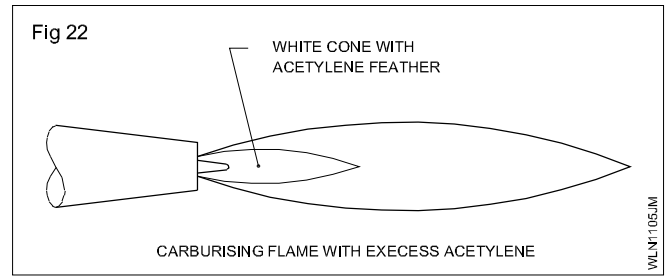
The gas mixture from the blowpipe has more volume of oxygen than acetylene.

To adjust the carburizing flame, adjust the flame to neutral and then add acetylene.

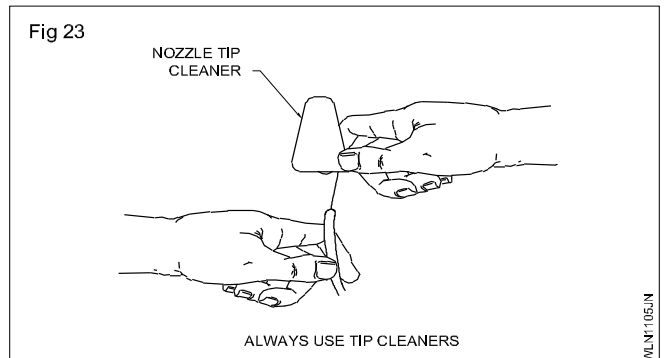
The white cone will become long surrounded by a feather like portion.

The flame will burn quietly having more length. (Fig 22)

The gas mixture from the blowpipe has more volume of acetylene than oxygen.



After continuous use of the blow pipe during welding the nozzle may get blocked by metal particles or spatters. This blockage has to be removed to get continuous flow of gases by using a nozzle cleaner. (Fig 23)



Repeat the setting of flames till you manage to set the flame without any backfire or flash back.

### Extinguishing the flame

To extinguish the flame close the acetylene control valve (blowpipe) first and then the oxygen control valve.

### Closing down the plant

At the close of work, shut off the plant in the sequence given below.

Close the acetylene cylinder valve.

Close the oxygen cylinder valve.

Open the blowpipe acetylene valve and release all the gas pressure.

Open the blowpipe oxygen valve and release all the gas pressure.

Both the pressure gauges on the regulators should read zero.

Release the acetylene regulator pressure adjusting screw.

Release the oxygen regulator pressure adjusting screw.

Close the blowpipe acetylene valve.

Close the blowpipe oxygen valve.

Ensure

- there is no fire around the equipment
- the gas is completely exhausted by dipping the nozzle in water.

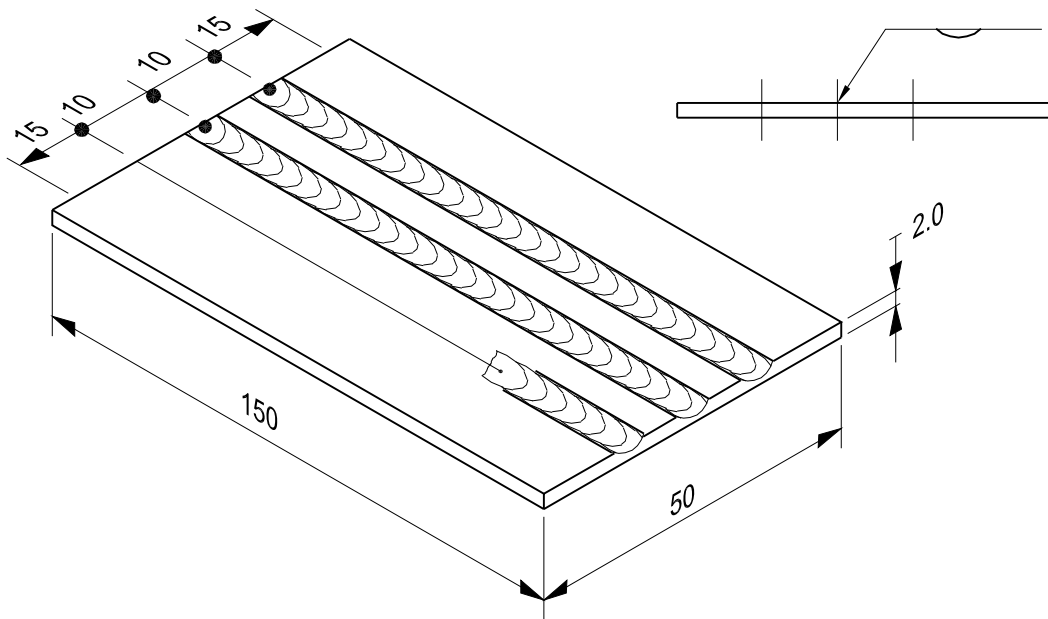


Scan the QR Code to view the video for this exercise

**Perform fusion run without filler rod on MS sheet 2mm thick in flat position (OAW-01)**

**Objectives:** At the end of this exercise you shall be able to

- set job for flat position welding
- select and fit the correct size nozzle according to the job thickness
- set gas pressure according to nozzle size
- fusion run without the filler rod in flat position using leftward technique
- clean the weldment and visually inspect for weld defects.



2	ISST 150 x 2.0-50	-	Fe310-W	-	-	1.1.06
NO.OFF	STOCK SIZE	SEMI-PRODUCT	MATERIAL	PROJECT NO.	PART NO.	EX. NO.
SCALE : NTS		<b>PERFORM FUSION RUNS WITHOUT FILLER ROD ON MS SHEET 2mm THICK IN FLAT POSITION (QAW-01)</b>			DEVIATIONS	TIME : 5 hrs
					CODE NO. WLN1106E1	

## Job Sequence

### Fusion runs without filler rod in flat position

- Mark and cut the M.S. sheet pieces of size 152 × 122 × 2.5mm using a hand lever shear.

**Care should be taken to keep the fingers off from the shearing blades. Wear gloves to avoid injury.**

- Straighten the cut pieces by hammering on an anvil.
- File and finish the sheet to dimensions as per drawing.
- Mark and punch parallel lines on the sheet surface as per sketch and set the job piece on the welding table in that position with fire brick support.
- Select and attach nozzle size 5 to the blowpipe.

**Wear safety apparels and gas welding goggles.**

- Set acetylene and oxygen pressure 0.15 kg/cm<sup>2</sup> on the regulators.
- Ignite the oxy-acetylene gases and adjust the neutral flame.
- Hold the blowpipe on the job at its right hand end at the required angle.
- Start heating the surface on the right end of the sheet with slight circular motion to the blowpipe and produce a molten pool on the marked line.

- Move the blowpipe from right to left direction maintaining a uniform speed and blow pipe angle.
- Avoid excessive concentration of heat at any one point.

**If the metal becomes too hot, lift the blowpipe momentarily away from the molten pool.**

**Do not touch the inner cone with the molten pool, to avoid backfire and flashback.**

- Keep the molten pool in correct size by adjusting the rate of travel and giving slight circular motion to the blowpipe.
- Stop at the left end and lift and blowpipe quickly.
- Extinguish the flame and cool the blowpipe in water.
- Clean the fused surface with a steel wire brush and inspect for the uniformity of fusion runs.

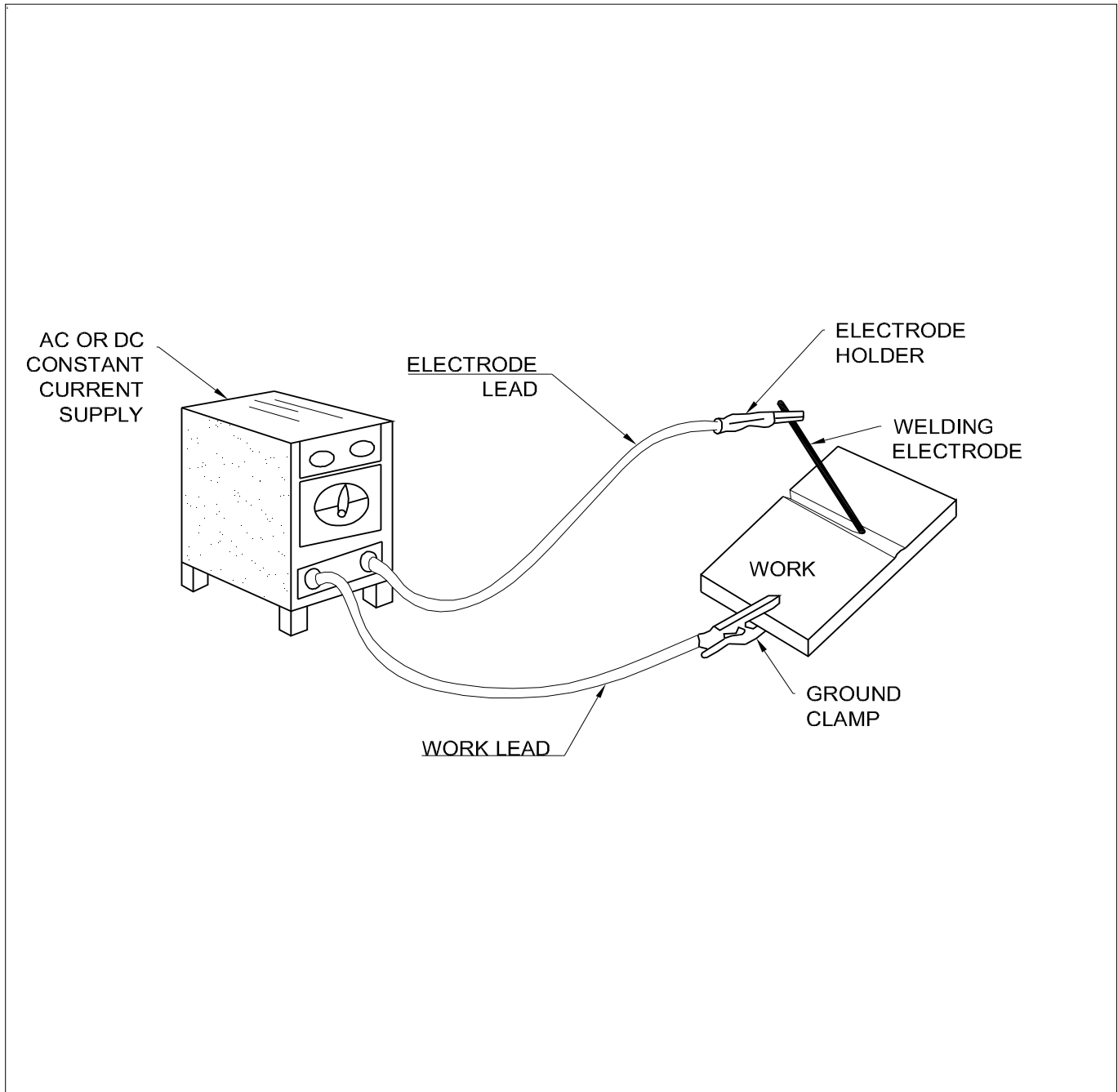
**If the speed of travel and blowpipe motion are correct, the fusion runs will appear with uniform width and even ripples.**

**Repeat the above 4 more times to achieve uniform fusion and better manipulation of blowpipe.**

Setting of arc welding machine & accessories and striking an arc (SMAW-01)

Objectives: At the end of this exercise you shall be able to

- connect the welding cables between the welding machine, electrode holder and the job
- start and operate the controls and stop are welding machine in sequence
- set welding current and strike and maintain the arc.



1	100ISF x 10-100	-	Fe310	-	-	1.1.07
NO.OFF	STOCK SIZE	SEMI-PRODUCT	MATERIAL	PROJECT NO.	PART NO.	EX. NO.
SCALE 1:1		<b>SETTING OF ARC WELDING MACHINE &amp; ACCESSORIES AND STRIKING AND ARC (SMAW-01)</b>			DEVIATIONS ±0.5	TIME 2h
					CODE NO. WLN1107E1	



## Job Sequence

- Set up the equipment in a safe place
- Organize the tools that you are using.
- Obtain the piece for welding and connect the ground clamp to one of them.
- Turn on the welding transformer.
- Set the amperage as per the suggested list on the machine.
- Insert the electrode in to the electrode holder into angled groove.
- Position the rod tip 25 to 50mm away from the welding position.
- Lower the helmet and now it is ready to strike the arc.

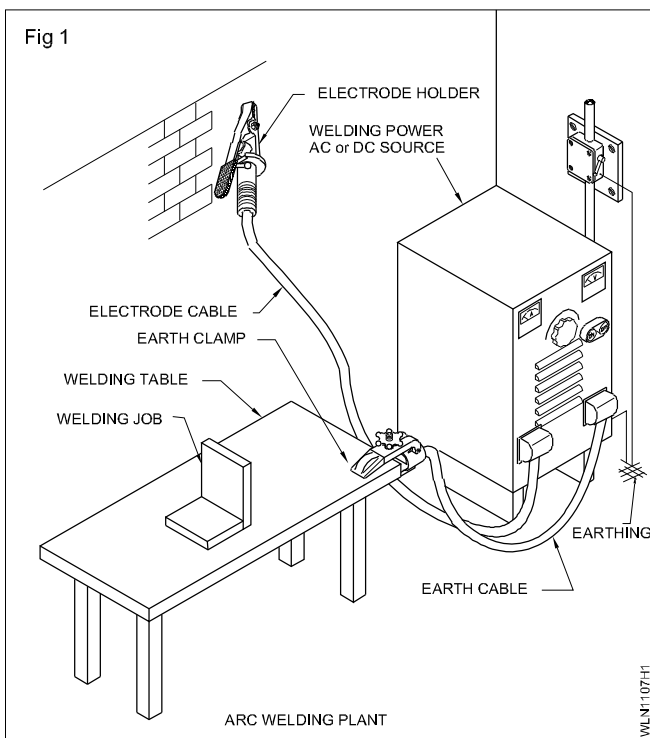
## Skill Sequence

### Setting of oxy-acetylene welding machine & accessories and striking an arc

**Objective:** This shall help you to

- assist in setting up arc welding plant.

#### Setting up Arc Welding plant (Fig 1)

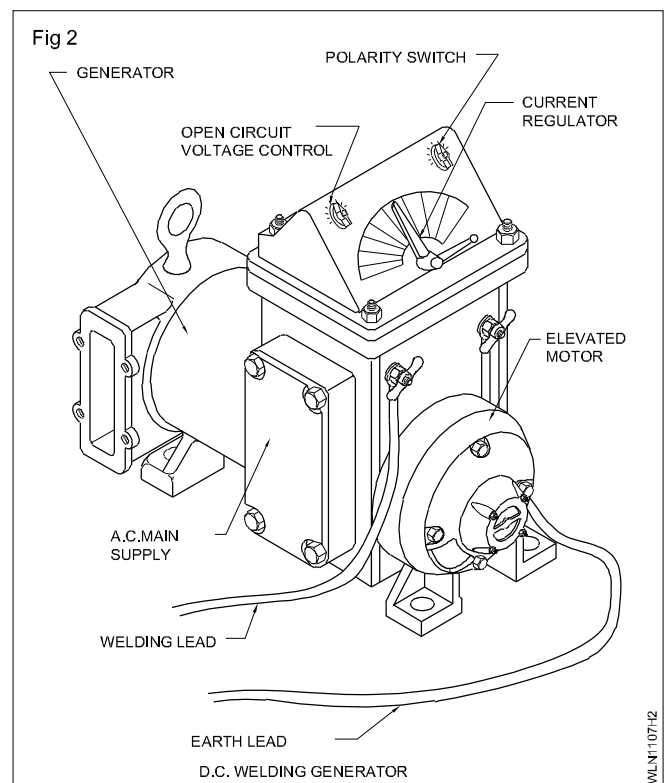


Check the welding machine and other accessories as per sketch. A welding generator (Fig 2) or a welding rectifier (Fig 3) gives a direct current for welding and a welding transformer (Fig 4) gives an alternating current for welding.

Connect the welding machine to the power supply.

**Be sure that the main supply switch and the welding machine are properly earthed. This will avoid any electric shock to the welder. Fig 1**

Switch on the starter.

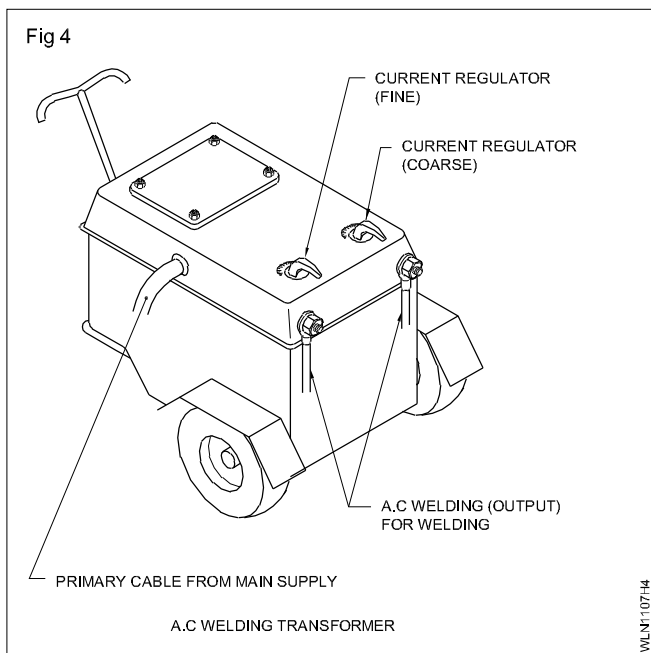
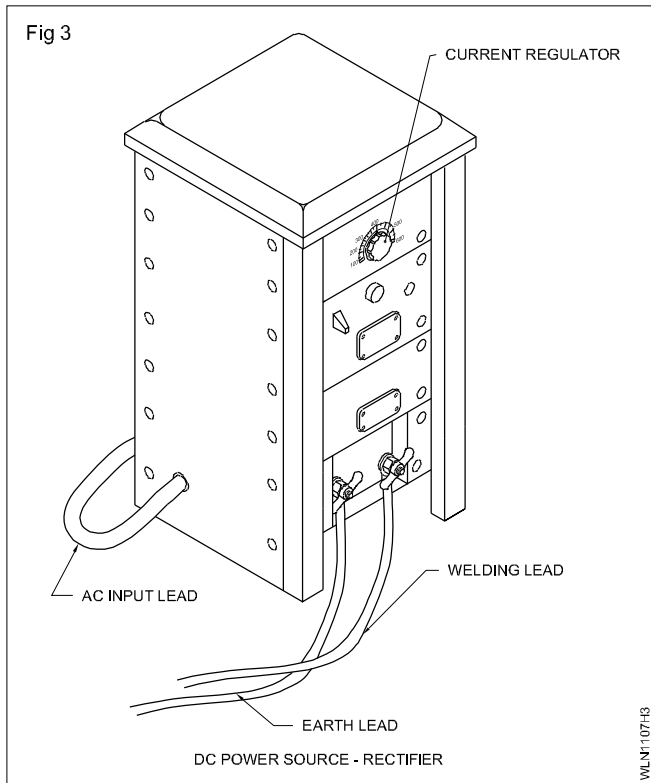


Check and ensure the electrode holder and earth cable are without any loose connection or damage.

**Loose cable connections cause spark, heat and unstable arc.**

Connect tightly the earth cable to the welding table or work using the earth clamp and the electrode cable with the electrode holder.

Hang the electrode-holder on an insulated hook provided near the welding table whenever it is not in use.



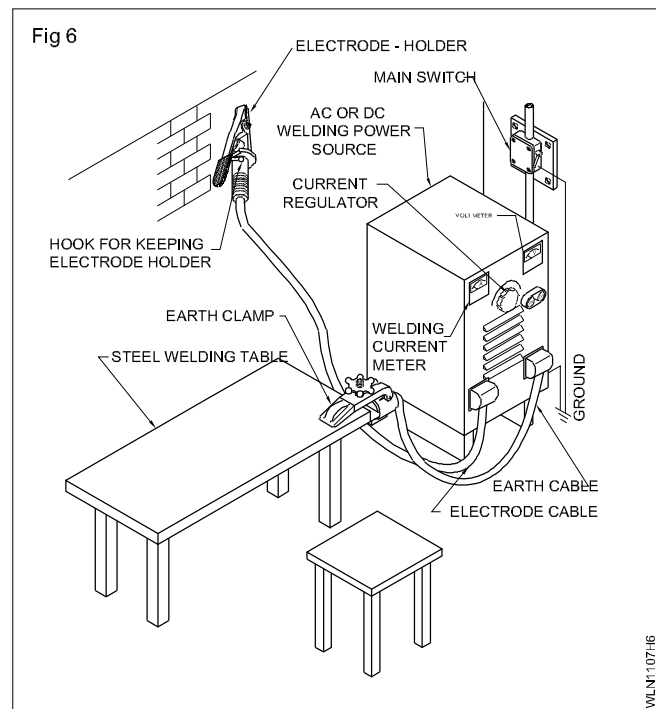
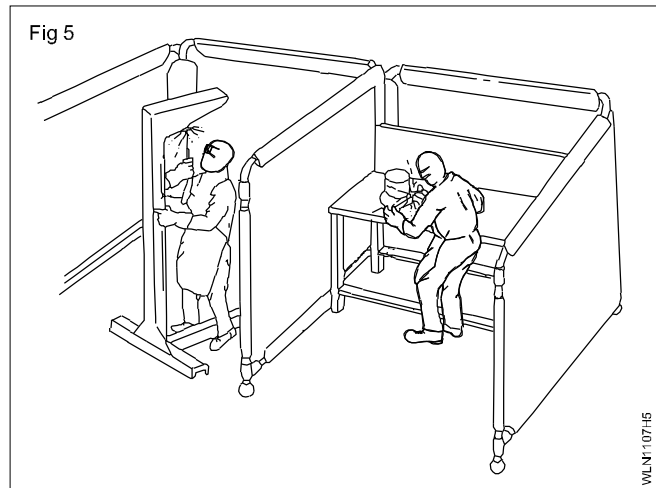
Place portable screens around the welding table for the safety of others. (Fig 5)

Check that the welding accessories such as chipping hammer, carbon steel wire brush, tongs and chipping goggles are in working condition.

Keep ready safety apparels (such as leather apron, gloves, sleeves, leggings, jacket, shoes and cap) to ensure personal safety.

Operating the controls of arc welding machines. (Fig 6)

Arc welding machines are used to get suitable current for welding purposes.



Connect the welding machine to the main supply as follows.

- Install the welding machine near the 3 phase main supply, keeping the mains supply cables as short as possible to avoid electrical power losses.
- Call a skilled electrician for permanent connections to the main supply since it carries dangerously high voltage.

Ensure that the main switch, fuses and power cables electrode holder, earth clamp and cable lugs are of the required ampere capacity.

If the main supply connection is of the plug type, the welder can himself connect the main supply.

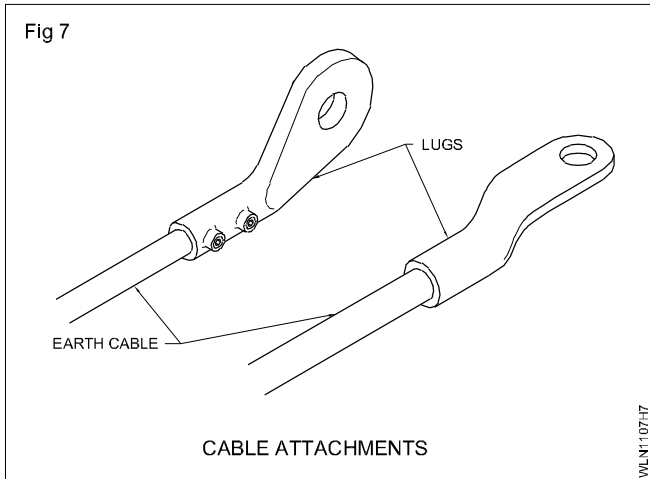
Check the proper operation of the main switch.

Check the proper operation of the on/off switch of the machine.

Check the proper operation of the current regulator of the welding machine and set the current at 110 ampere for a 3.15mm diameter electrode.

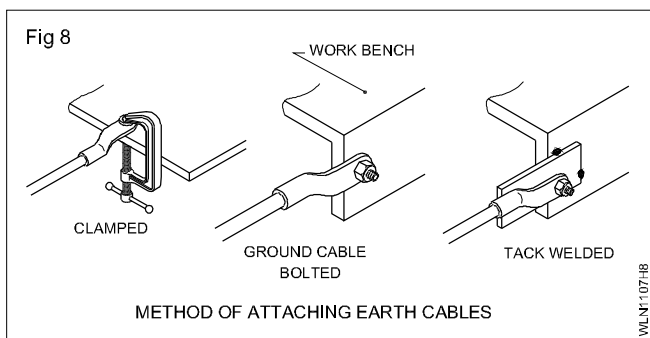
Check the operation of the polarity switch, if it is a DC welding generator or a rectifier.

Welding cables are used to carry the welding current from the welding machine to the electrode-holder and the job and suitable lugs are attached to the earth cable ends (Fig 7).



Connect one end of the earth cable to one of the output terminal of the machine tightly.

Connect the other end of the earth cable with the welding table or work tightly using the earth clamp as shown in Fig 6. Other methods are shown in Fig 8.



Connect one end of the electrode cable to the second terminal of the machine and the other end to the electrode holder.

### Starting and stopping of arc welding machines

#### Welding transformer

Switch 'on' the main supply of the welding transformer.

Start and stop the welding transformer (2-3 times) using the on/off switch provided on the machine.

#### Welding generator

Switch 'on' the main supply of the welding generator.

Start and stop the welding generator (2-3 times) using start-delta-starter provided on the machine.

Put the starter in star position, wait for a few seconds and then put the switch in delta position to avoid damage to the machine.

#### Welding rectifier

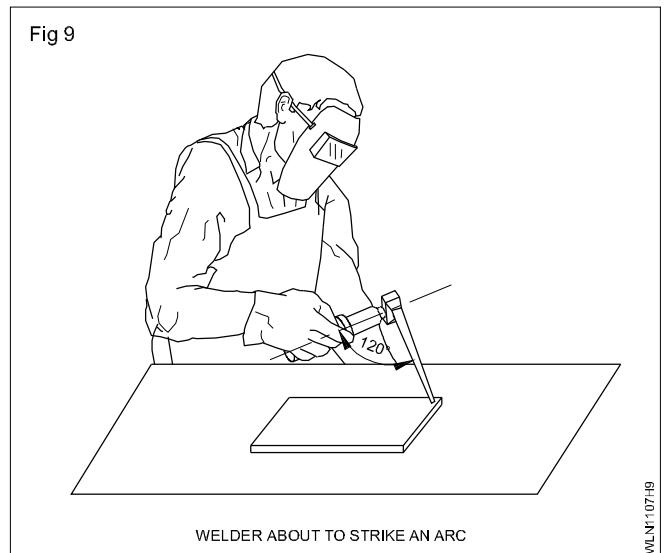
Switch 'on' the main supply of the welding rectifier.

Start and stop the welding rectifier 2-3 times using the 'on' - 'off' switch provided with the machine.

**In some of the rectifiers, a transfer switch is provided. By operating this switch the machine can be used as DC welding machine or as AC welding machine.**

#### Striking of arc on mild steel (M.S.) plate in flat position

Fix a 3.15 mm dia medium coated mild steel electrode between the jaws of the electrode holder. (Fig 9).



Ensure the bare wire end of the flux coated electrode is firmly held in the slot/groove provided in the electrode holder.

Set 110 ampere for the 3.15  $\phi$  electrode. All electrode manufacturers indicate the current values for different size electrodes which can be used as a guide while setting currents.

Striking the arc is a basic action whenever a welder has to start welding or an electrode is changed or an arc is put-off during welding.

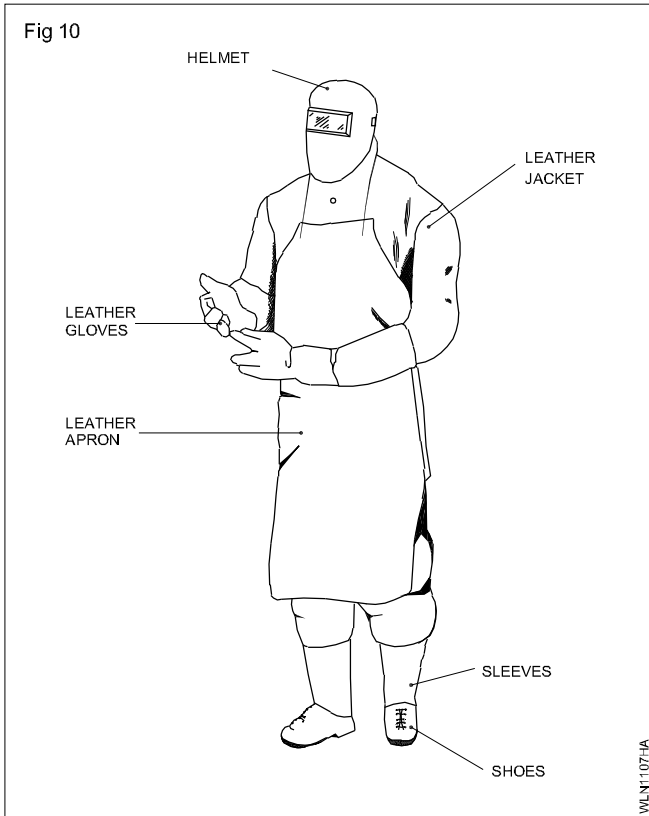
Connect the electrode to negative if the machine is a DC welding machine.

Clean the given scrap iron plate (work piece) surface with a steel wire brush, and clean the oil or grease, water and paint, if any.

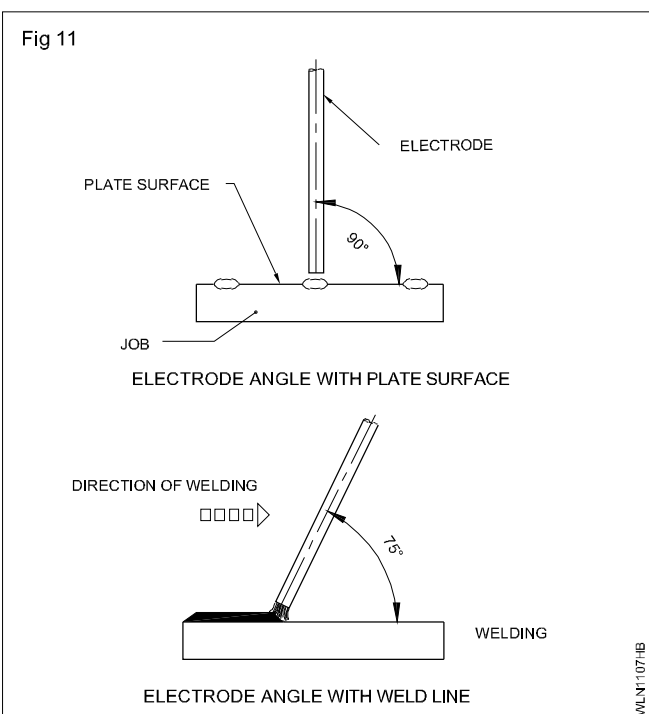
**Improper cleaning makes poor electrical contacts and weak welds due to weld defects.**

Set the work piece on the welding table in a flat position.  
Switch 'on' the input supply and start the welding machine.

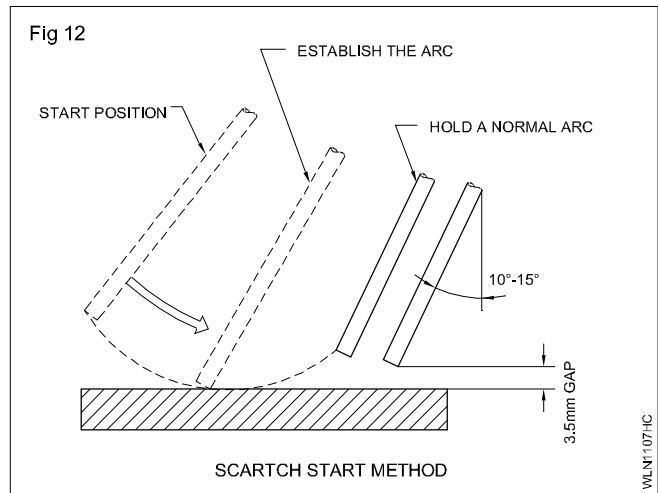
**Ensure safety apparels are worn. Fig 10**



Hold the electrode about 5 mm above the job piece at one end at 75° angle to the line of weld and at 90° to the plate surface. (Fig 11)



**Scratching method (Fig 12)**



Put on the welding helmet or bring the welding shield in front of your eyes.

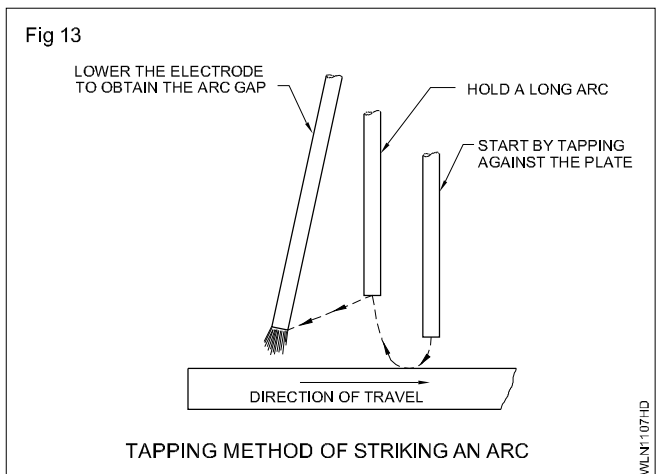
Strike the arc by dragging the electrode quickly and softly across the welding job using wrist movement only.

Withdraw the electrode approximately 6 mm from the surface for a few seconds and then lower it to approximately 3 mm distance to maintain the arc. (Fig 12)

If the arc has been properly struck a 'burst of light with a steady sharp crackling sound' will be produced.

To break the arc quickly withdraw the electrode up.

**Tapping method (Fig 13)**

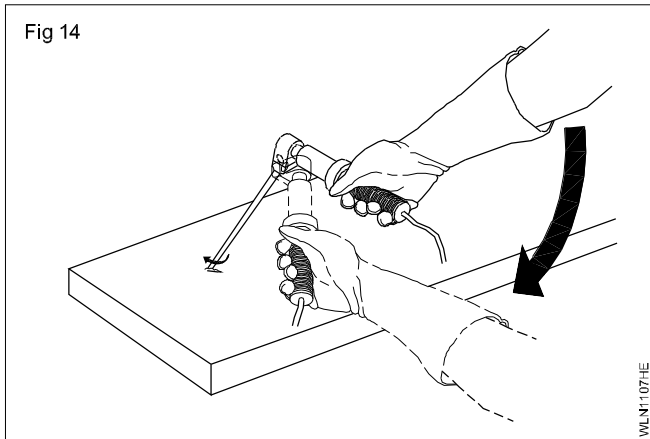


Strike the arc by moving the electrode down to touch the job surface lightly.

Lift the electrode up slowly approximately 6 mm for a few seconds and then lower it to approximately 3 mm from the surface to maintain a correct arc.

The tapping method is mostly recommended as it does not put pit marks on the job surface.

If the electrode freezes (sticks) to the plate, it should be immediately freed by a quick twist of the wrist to avoid its overheating or spoiling. (Fig 14)



Strike the arc by the scratching method.

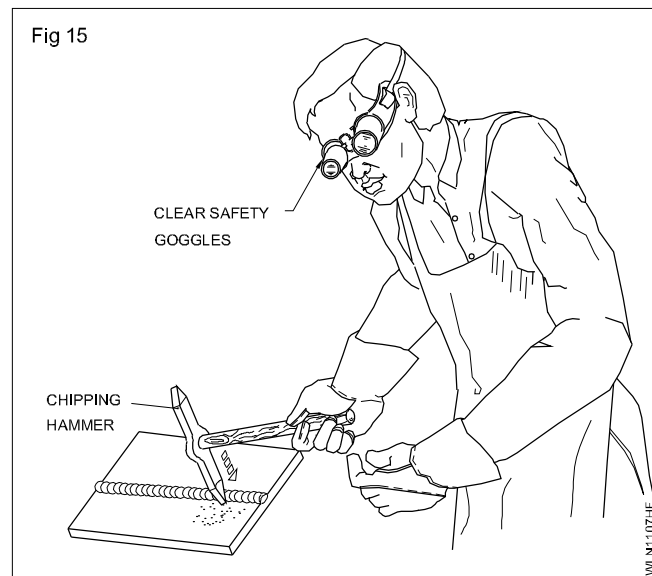
Look at the arc through the filter glass only fitted in the welding screen/shield or helmet.

Remove the slag covering from the top of the short weld deposits by using a chipping hammer, and clean with a wire brush. Fig 15.

Use chipping goggle or chipping screen, while Deslagging welds. Fig 15

If the welded job is small in size use tongs to hold a hot job.

Repeat striking the arc on the scrap MS plate until the arc can be struck every time without the electrode freezing.



### Safety precautions during arc welding

During metal arc welding, the metal is heated and fused by the heating source - electric arc. The following are the common dangers involved.

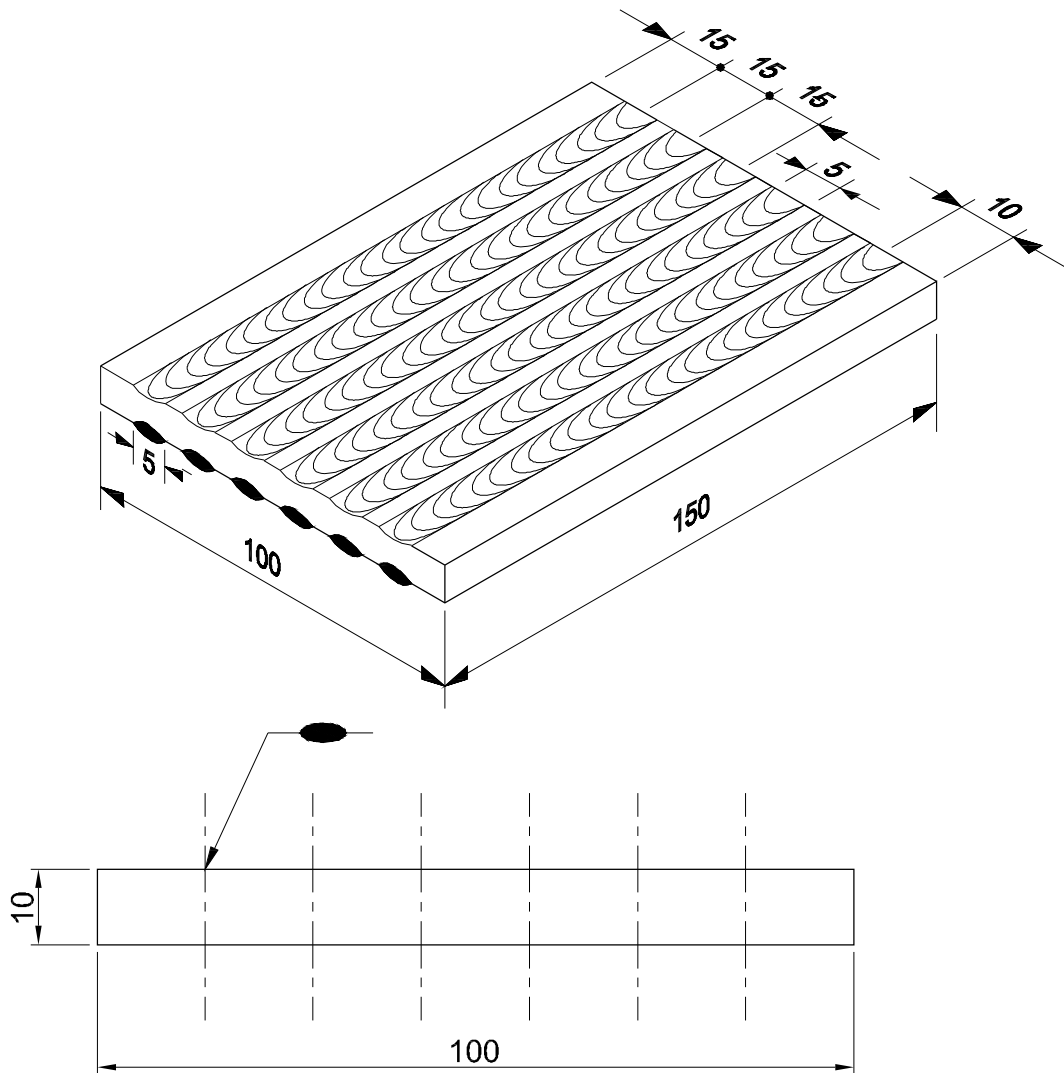
- Electric shock
- Sparks and spatters
- Smoke and fumes
- Heat radiation
- Chipped and hot slag particles
- Hot jobs and the hot stub ends.

To protect the welder from the above dangers, he has to follow certain safety precautions which are explained in the Related Theory on Induction Training.

**Deposit straight line bead on MS plate in flat position**

**Objectives:** At the end of this exercise you shall be able to

- prepare and set job pieces for straight line beading
- select the electrode, current and polarity for depositing the weld beads
- deposit uniform straight bead in flat position by arc welding
- maintain constant arc length, electrode angle and travel speed
- restart a broken arc and fill the crater properly
- remove and clean the slag and spatter from the weld bead using a chipping hammer and wire brush
- inspect deposited beads for any surface defects.



1	100ISF x 10-100	-	Fe310	-	-	1.1.08
NO.OFF	STOCK SIZE	SEMI-PRODUCT	MATERIAL	PROJECT NO.	PART NO.	EX. NO.
SCALE 1:1	<b>DEPOSITE STRAIGHT LINE BEADS ON M.S PLATE 10mm THICK IN FLAT POSITION.</b>				DEVIATIONS ±0.5	TIME 5 Hrs
					CODE NO. WLN1108E1	

## Job Sequence

- Prepare the plates to size (as per drawing) by Hacksaw cutting and grinding.
- Clean the plate surface (job) with a stainless steel wire brush and remove the burrs by filing.
- Lay out parallel lines on both sides of the job surface as per sketch and mark with a center punch.
- Set the plate on the welding table in a flat position.
- Ensure the plate is contacting well with the welding table and the earth clamp is not loosely connected with the work table.
- Wear protective clothing (safety apparels).
- Use welding goggles.
- Ensure the filter glass of the welding shield is in good condition.
- Fix a 4 mm  $\varnothing$  M.S. electrode in the holder.
- Set the welding current to 150 to 160 amps approximately.
- Connect the electrode cable with the transformer welding machine. In case of a DC welding generator or rectifier, connect it to the negative terminal.
- Connect the earth clamp on the right extreme end of the job/work table.
- Start the welding machine.
- Strike the arc on a scrap piece for trial and observe the current setting.
- Ensure the burning of the electrode is normal and the arc is smooth.
- Re-adjust the welding current if necessary.
- Use a short arc.
- Deposit straight line beads on the work piece along the punched line from the left hand end to the other end.
- Hold the electrode at 70° to 80° to the line of weld. Move it along the line of weld and towards the job at uniform speed.
- Restart the bead whenever the arc is broken and ensure to fill the crater.
- Fill the crater at the end of the bead without fail.
- Remove slag from the weld bead using a chipping hammer and clean with steel wire brush.
- Use a chipping screen while Deslagging.
- Inspect deposited beads for:
  - uniform width and height
  - straightness
  - uniform ripples
  - slag inclusion
  - unfilled crater
  - porosity
  - undercut
- Repeat the exercise on the other side of the plate.

## Skill Sequence

### Straight line bead on MS plate in flat position

**Objective:** This shall help you to

- **set and weld the straight line beads on MS plate in flat position.**

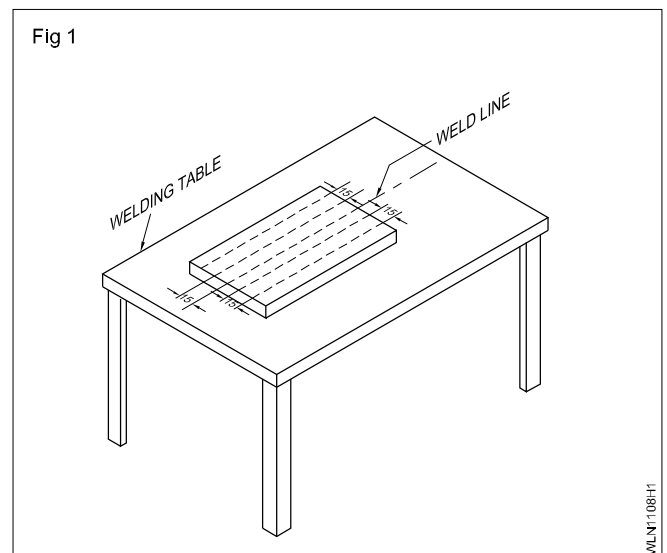
Prepare a M.S. plate piece 100×150×10 using a hacksaw and file.

Mark straight line, punch the line keeping 15mm distance in between. (Fig 1)

Set the job on the welding table in a flat position with the punched surface facing up. (Fig 1)

The bottom surface of the job should be perfectly clean to get good electrical contact between the job and the welding table.

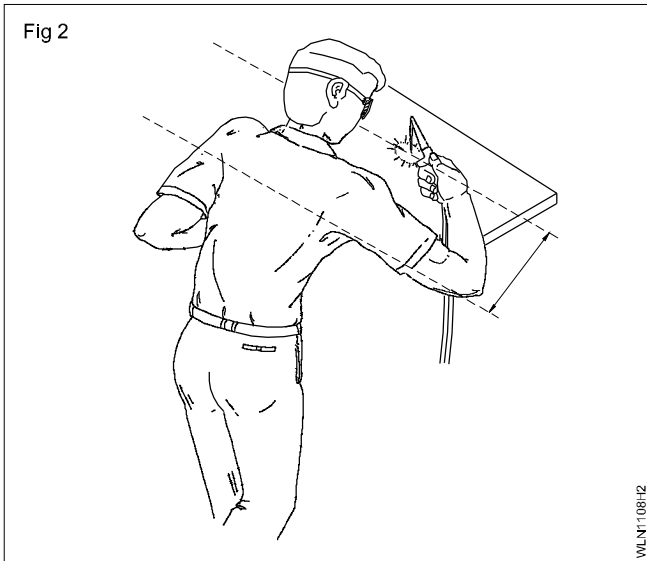
Always follow the current range according to the diameter of the electrode, as given in the electrode packet by the electrode manufacturer.





Check for proper melting of the job and electrode on a scrap metal piece.

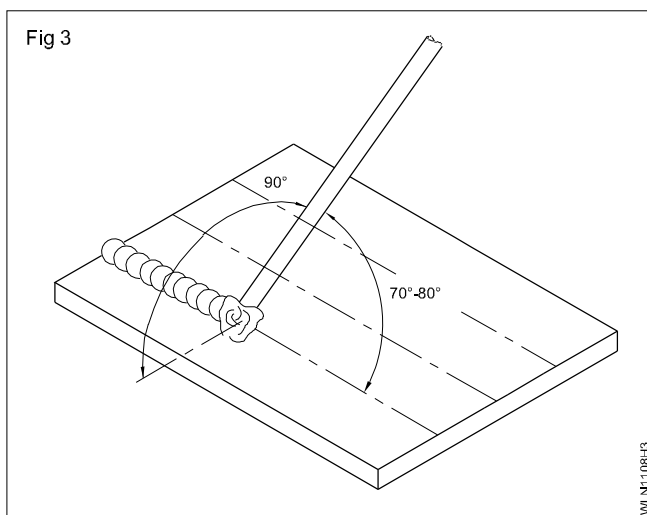
Hold the electrode at an angle of 70° to 80° with weld line/punched line. (Fig 2)



When a DC welding machine is used connecting the earth cable at the right end of the job or work table will help to deposit the weld metal at the correct place in the joint.

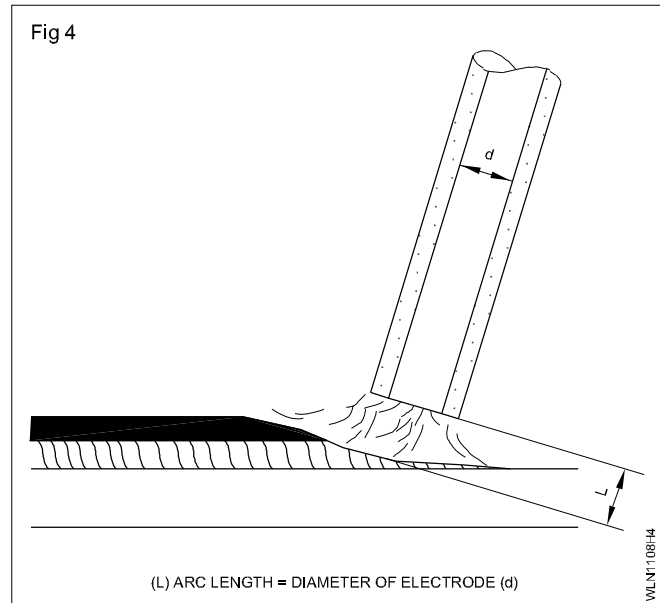
Deposit straight line beads taking the punched lines as a guide maintaining:

- the medium arc length (L) (i.e. equal to dia. of electrode used (d). If a DC welding machine is used then use of a short arc length will help to reduce the deviation of the molten metal from its intended path.
- correct travel speed (approximately 150 mm per minute)
- correct electrode position/angles. Fig 2 and 3



The electrode should be moved towards the job to maintain a gap between the tip of the electrode and the molten pool. (Fig 4)

Welding screen glasses should be clean enough to see the arc action on the molten pool and punched line mark.

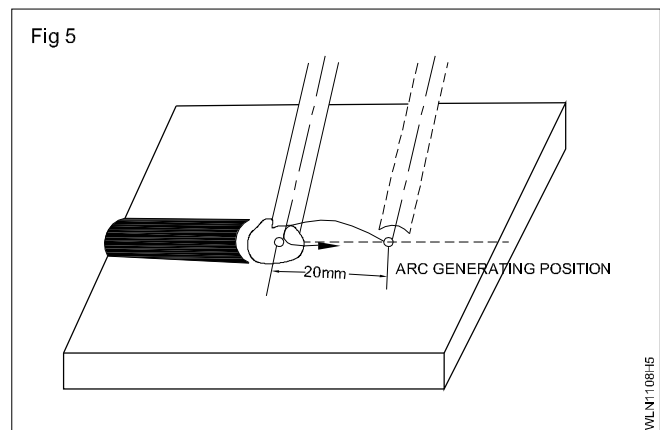


Listen to the arc's steady sharp crackling sound while welding. It indicates uniform burning of the electrode.

Adjust the travel speed by watching the electrode melting rate and flowing through the molten pool to form the deposited metal. The uniform travel speed of the electrode along and towards the line of the weld gives a uniform bead.

Whenever the arc is broken a depression called crater is formed at the breaking point and this crater has to be filled first while restarting the arc. So clean the crater and generate an arc at about 20mm ahead of the crater and return to the crater at a faster rate.

Build the deposit so that it fills the crater, then move the electrode ahead. Fig 5.



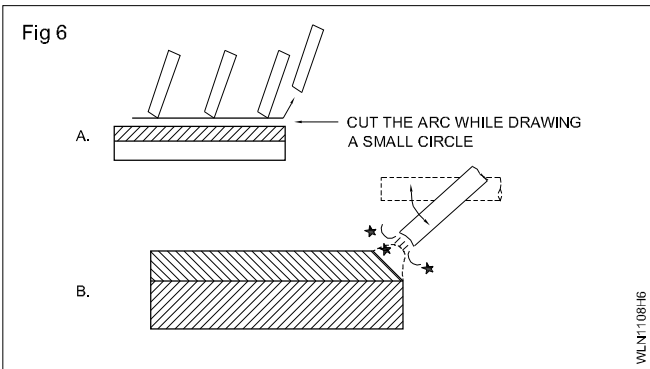
Also after completion of each bead fill the crater as follows. Fig 6

Build the deposit on the crater so that it is the same level as the welding bead.

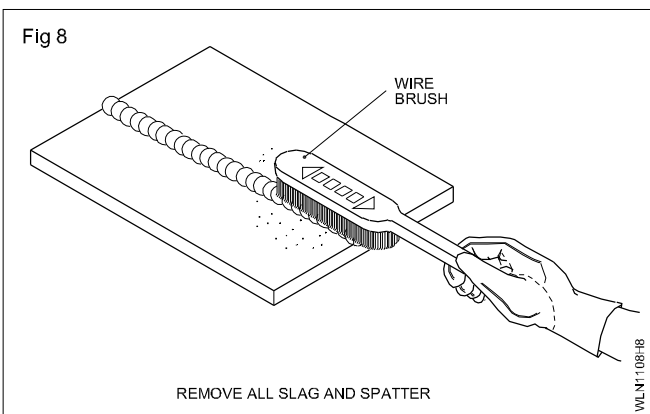
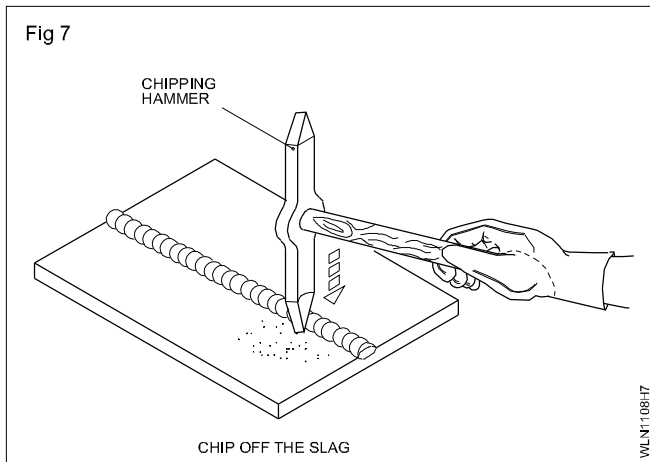
- Let the arc length be shorter at the end of the run and draw a small circle 2 to 3 times.
- Repeat Off and On the arc at the end.



Fill the crater. Fig 6



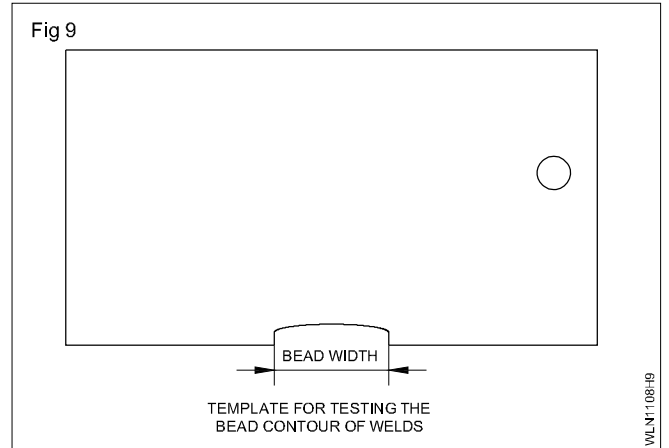
Remove the slag and spatters from the weldment using a chipping hammer and wire brush, so that the metal surface of the bead is exposed for checking for any defects. (Figs 7 and 8)



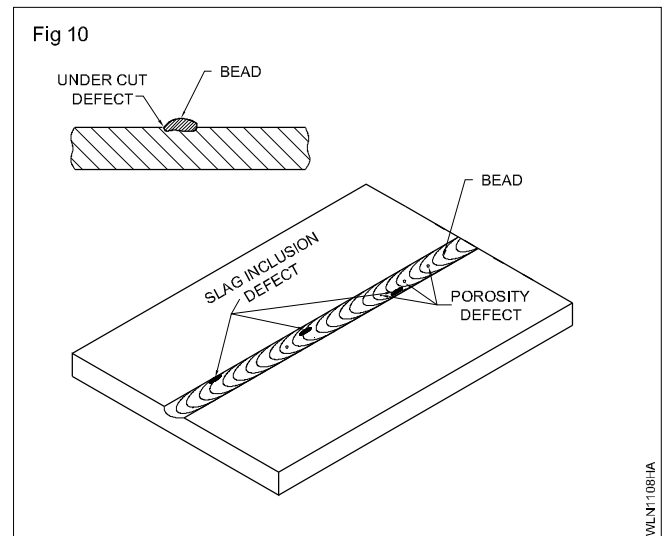
Determine the causes for the above weld defects and use the remedial/prevention methods in further deposits.

Check the deposited beads and note any variation in the:

- width and height using a template Fig 9.



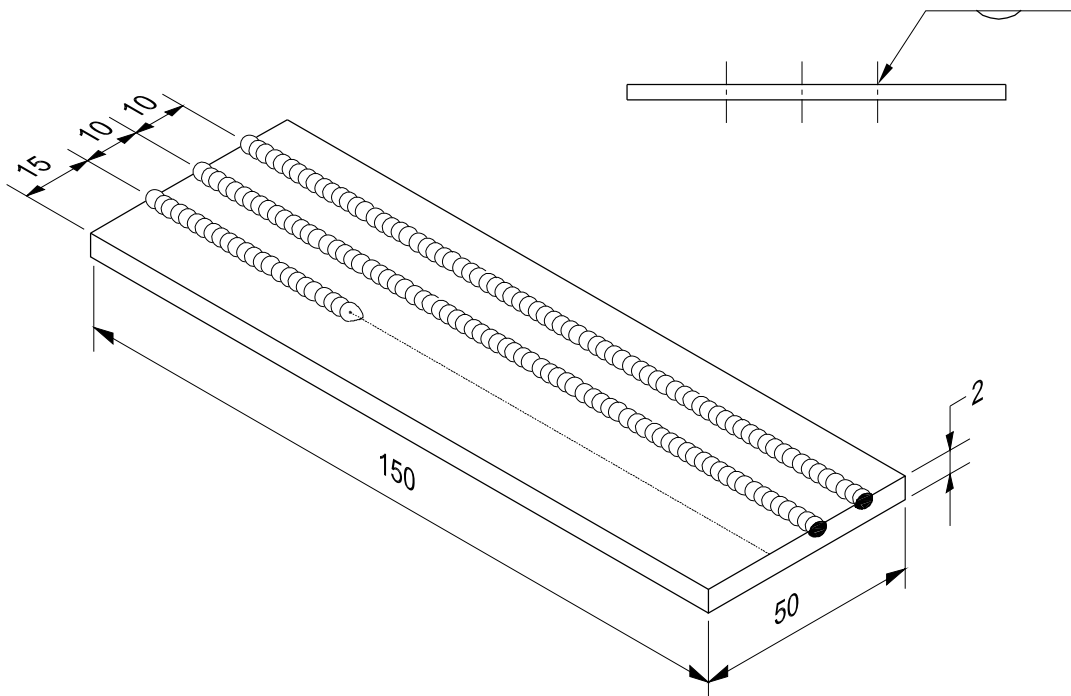
- depth of fusion
- straightness of the run
- check for surface defects such as slag inclusion, surface porosity, undercut, improper bead profile etc.



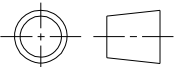
Depositing bead with filler rod on MS sheet 2mm thick in flat position

Objectives: At the end of this exercise you shall be able to

- manipulate the blowpipe and filler rod in the correct position for fusion cut
- fusion run by adding filler metal, using the leftward technique in a flat position with the correct type of flame
- clean the weldment and visually inspect for weld defects.



Note: Permit the trainees to repeat until he/she acquired the required skill.

2	ISSH 160 x 2.5-50	-	Fe310-W	-	-	1.1.09
NO.OFF	STOCK SIZE	SEMI-PRODUCT	MATERIAL	PROJECT NO.	PART NO.	EX. NO.
SCALE : NTS	<b>DEPOSITE BEAD WITH FILLER ROD ON M.S SHEET 2mm THICK IN FLAT POSITION</b>				DEVIATIONS	TIME : 10 Hrs
					CODE NO. WLN1109E1	

## Job Sequence

### Fusion run with filler rod in flat position

- Select and fix the nozzle size 5 and set acetylene / oxygen pressure 0.15 kg/cm<sup>2</sup>.
- Select copper-coated mild steel (CCMS) filler rod of  $\varnothing$ 1.6 mm.
- Wear safety apparels and gas welding goggles.
- Ignite the oxy-acetylene gases and set the neutral flame.
- Hold the blowpipe on the right hand at an angle of 60° - 70° with the punched line of the job and make a small molten pool at the right hand edge of the line.
- Keep the flame cone distance 2.0 to 3.0 mm above the job surface.
- Hold the filler rod in the left hand, pointing near the molten pool with an angle of 30° - 40° with the line of weld.
- Melt the base metal at the right end of a punched line and create a molten pool/puddle.
- Fuse the end of the filler rod by dipping at the center of the molten pool and add filler metal on the job surface to form a weld bead.
- Move both the blow pipe and the filler rod towards left with uniform speed along the punched line with a slight circular motion to the blowpipe.
- Move the filler rod up and down (piston like motion) at a constant speed.
- Add enough rod into the molten pool to build up the bead evenly in height and width.
- Adjust the rate of travel of the blowpipe with the filler rod to control the size of the bead and the required penetration/depth of fusion.
- Keep the filler rod end within the flame outer flame to avoid oxidation.
- Stop at the left hand end of the punched line by filling the crater properly.
- Extinguish the flame and cool the nozzle.
- Clean the weld surface. Inspect for even ripples and uniform width/height of weld bead.
- Repeat this for the remaining 4 more punched lines to achieve better manipulation of blow pipe and filler rod.

## Skill Sequence

### Fusion run with and without filler rod

**Objective:** This shall help you to

- **set and carry out fusion run with and without filler rod.**

The beginner for gas welding must practice:

- holding the blowpipe in the correct position
- fusing of the metal by using a proper blow pipe manipulation
- getting proper coordination of both hands to manipulate the blow pipe and filler rod together
- deposit fusion run in a straight line from the right end to the left end of the job.

#### Preparation of sheet for welding

**Use gloves while handling sheets.**

Shear the MS strip to get job pieces 152 mm long  $\times$  122 mm wide  $\times$  2.5 mm thick.

2 mm is the shearing allowance so that the finished size after filling will be 150  $\times$  120mm.

Remove buckling of sheet due to shearing by hammer on the anvil.

File the irregular edges of the job to remove burrs and unevenness on the edge to get a sheet size of 150  $\times$  120mm.

#### Cleaning and setting job piece

Remove rust if any using a wire brush and emery paper.

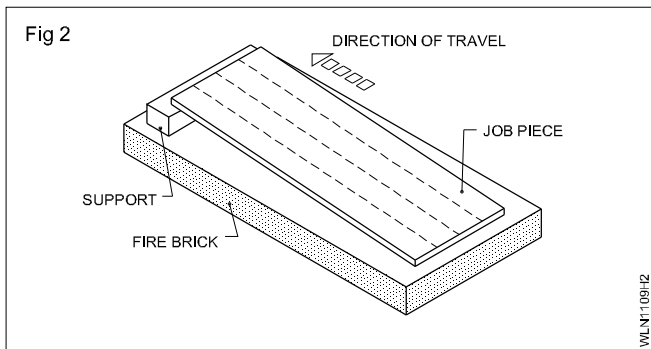
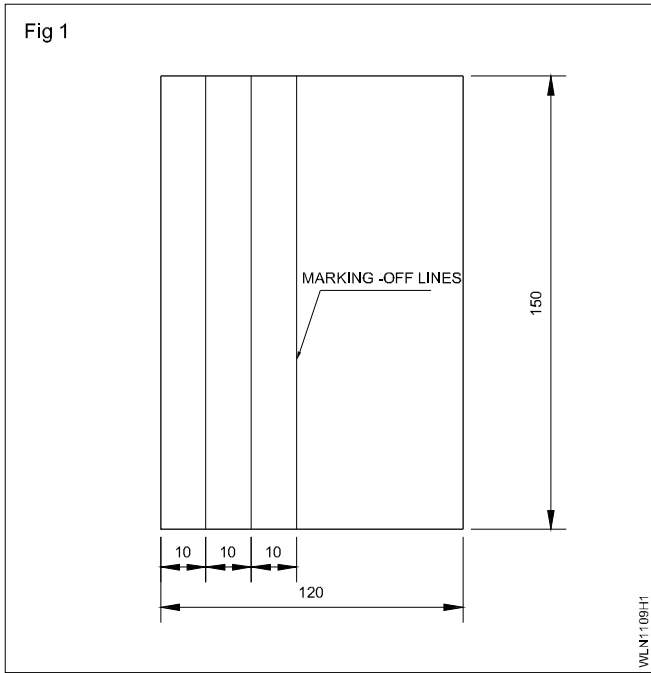
Do not rub with heavy pressure on the wire brush.

Use the emery paper rolled on a piece of wood while cleaning.

Remove paint, oil or grease by dipping the M.S. sheet in a solvent of dilute hydrochloric acid.

Draw lines parallel to the longer edge of the sheet at 10mm from one edge and punch along the lines to serve as a guide. Fig 1

Keep the job on the work table on a fire brick (Fig 2) to reduce the heat conduction and to position the job flat.

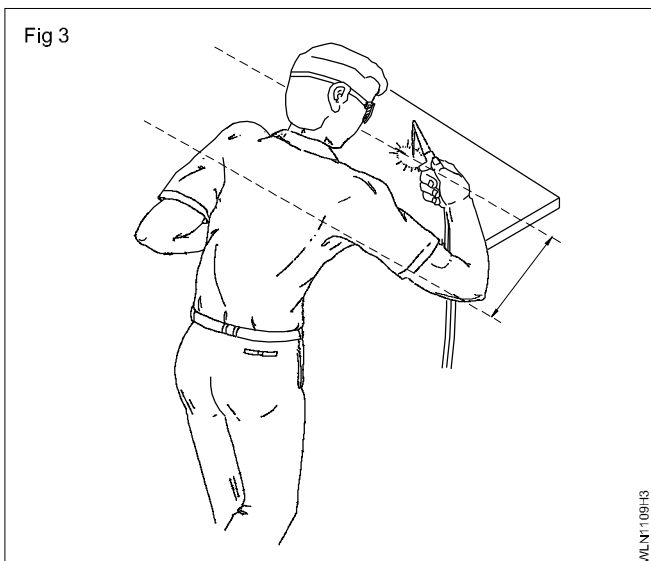


Use welding goggles.

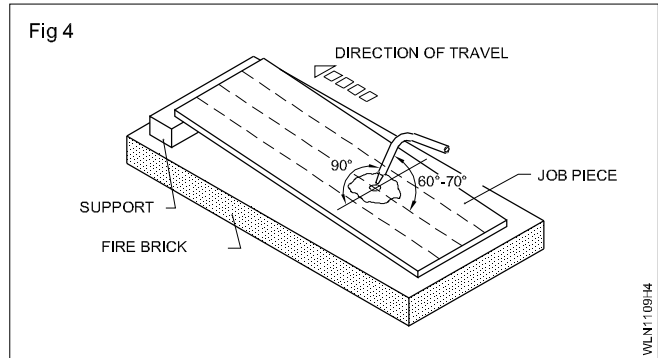
Hold the blowpipe and flame in correct position (angle) for proper fusion.

Position the blowpipe in such a way that:

- the punched lines of the sheet is parallel to the operator (Fig 3)



- there is less fatigue to the hand of the operator
- the angle of the nozzle with the welding line is between  $60^\circ - 70^\circ$ . The angle between the nozzle and the job surface should be  $90^\circ$ . (Fig 4)

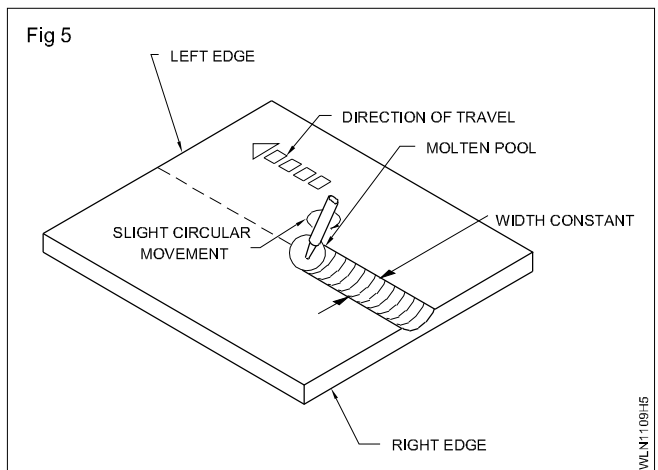


Fuse the metal to form a small puddle of molten pool on the job surface at the right end.

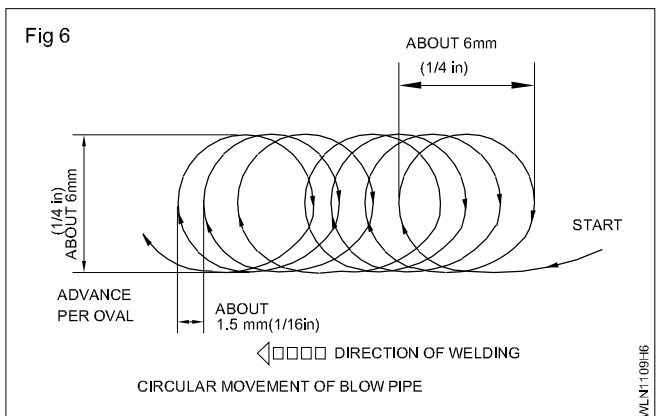
### Making fusion run without filler rod

Move the blowpipe in the leftward direction as location fusion is obtained at the right end of a line.

Keep the molten pool on the punch line. (Fig 5)



Maintain constant speed of travel with slight circular motion to the blowpipe. (Fig 6)

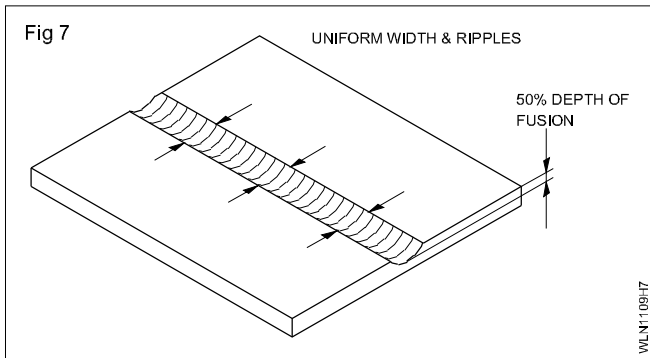


Reduce the blowpipe angle slightly near the left edge and slowly withdraw the flame to avoid burn through at the end.

Maintain a constant distance of 2-3mm between the white cone of the flame and the sheet surface for proper heat input and to avoid backfire.

### Visual inspection of fusion run

Visual examination can be done to ensure uniform width, ripples and proper depth of fusion (penetration) (Fig 7) for the bead after the welded job is cleaned thoroughly to remove the scales from its surface.



**Use tongs while handling hot jobs.**

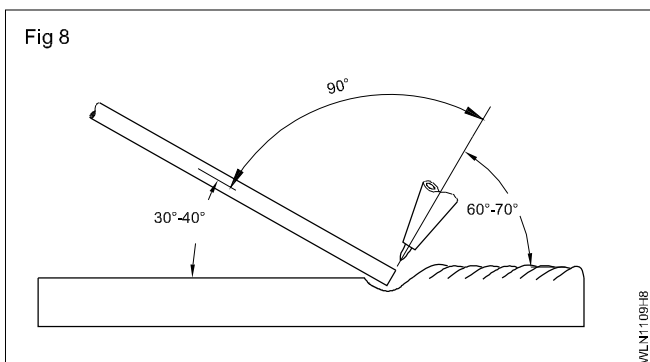
**Making fusion run with filler rod:** During gas welding, most of the joints require filler metal to obtain proper size of weld and to get a strong joint. So while the flame melts the base metal, it also melts the filler rod to fill the groove or depression in the joint.

The feeding of filler metal in molten pool requires special skills.

The heat input by the flame depends on the volume of acetylene and oxygen gas burnt. Different size nozzles will give different volume of gases and heat required to melt the metal depends on the thickness of metal to be welded. So select nozzles based on thickness of base metal to be welded.

For 3.0mm thick MS sheet select No. 5 nozzle and fix it to the blow pipe.

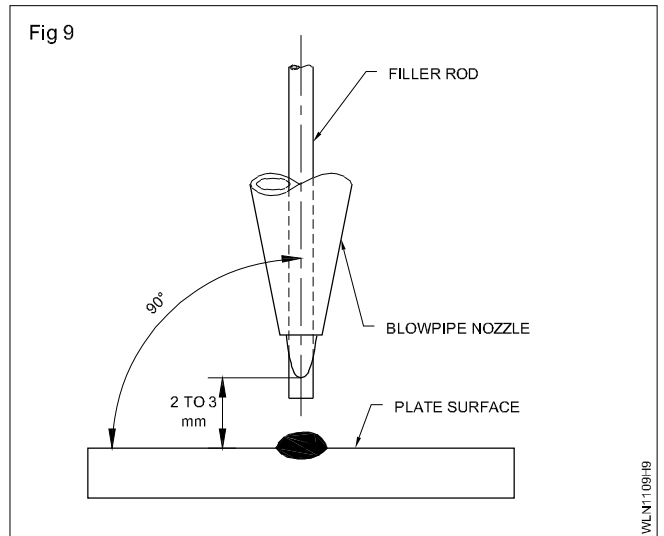
Blowpipe angle  $60^{\circ}$  -  $70^{\circ}$  with weld line (towards right). Filler rod angle  $30^{\circ}$  -  $40^{\circ}$  with weld line (towards left). (Fig 8)



This angle helps in moving the molten puddle along the line of weld and keeps the unwanted materials like scale, any dirt, etc. away from the molten pool. This also controls the depth of fusion (penetration) to the required

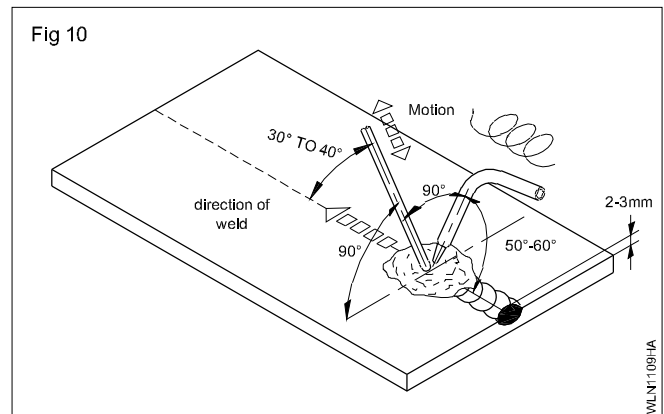
extent. In addition the visibility of the melting region is better.

Keep the blowpipe and filler rod at  $90^{\circ}$  to the plate surface, so that the metal melts equally on both sides of the inner cone of the flame. (Fig 9)



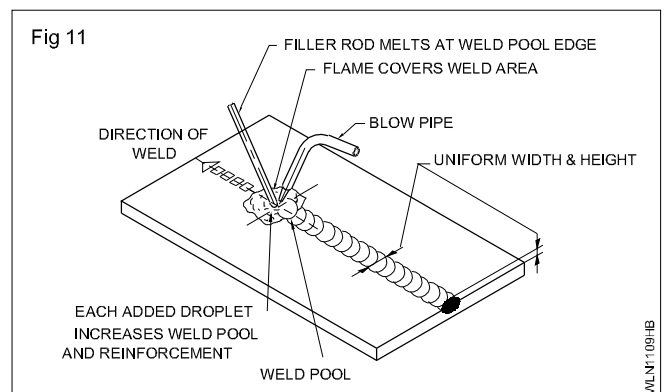
Fuse the metal surface, maintain the molten pool and add filler metal with proper motion.

For the blowpipe, a slight circular motion is required and for the filler rod, a piston like motion (Fig 10) (up and down) is required.



Maintain the flame cone distance to metal surface 2-3 mm.

Move the blowpipe and filler rod in leftward direction, along the punch-marked straight line, to progress the weld. (Fig11)



Add filler rod in the weld pool to get 0.5 to 1 mm weld reinforcement above the sheet surface.

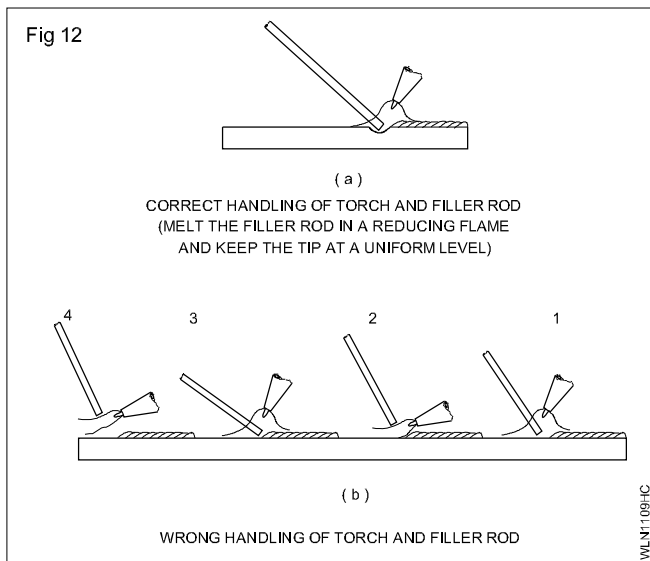
Maintain constant speed, angles and motion during welding for the blowpipe and the filler rod.

Keep the end of the filler rod within the outer envelope of the flame to avoid its oxidation.

### Restarting and stopping of weld

#### Restarting

Hold the blowpipe nozzle at 80° angle with the cone pointing on the last 3 mm of weld bead deposited i.e. the crater. (Fig 12)



Re-melt the weld bead at crater to form a molten pool, add filler rod and proceed with the deposition.

#### STOPPING

Reduce the angle of the blowpipe and filler rod as the weld pool reaches the left end to control burn through.

Build up the crater by adding enough filler metal, by dropping a few drops of molten metal at the crater.

Remove the flame slowly but cover the weld pool with the end of the flame's outer envelope to protect it from atmosphere.

Remove the filler rod end from the weld zone before the weld pool solidifies.

### Inspection of the deposited run

Look for the following on the deposited bead.

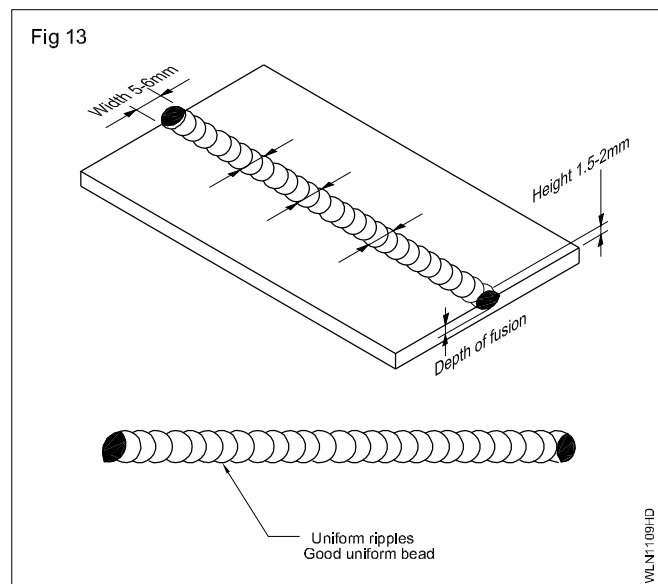
Depression at various points on the bead. (This is due to variation in speed of travel of the blowpipe; improper feeding of the filler rod; wrong restarting; splashing of molten pool due to inner cone of flame touching the molten metal.)

Undercut at the toes of the bead. (This is due to excessive pressure of gases and setting harsh flame; improper manipulation of the blowpipe; improper feeding of the filler rod.)

Concave bead surface. (This is due to harsh flame and excessive pressure of gases; inadequate feed of filler rod.)

Porosity. (This is due to improper cleaning of the sheets; rusted filler rod.)

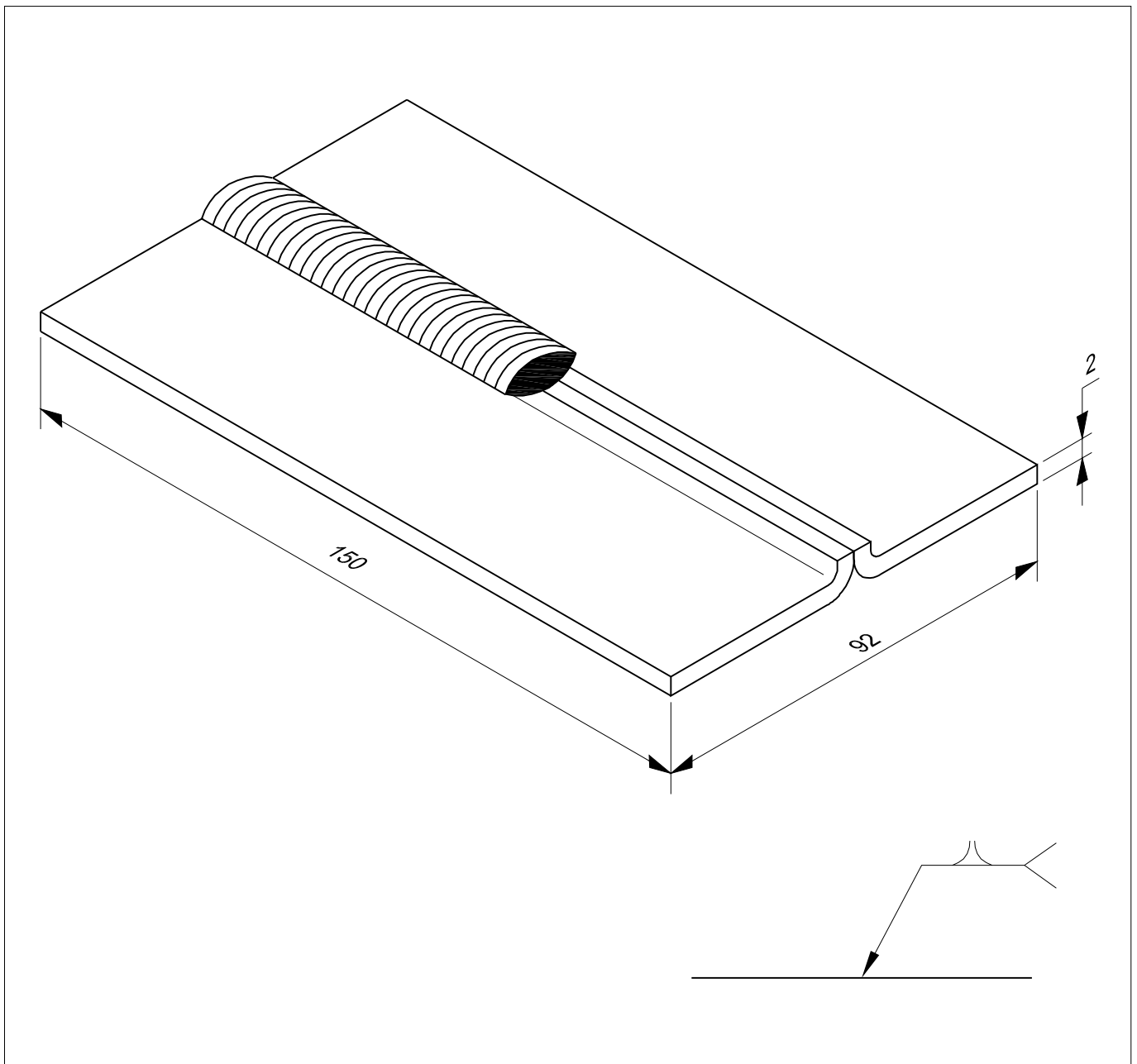
The correct bead is shown in Fig 13.



**Edge joint on MS sheet 2mm thick in flat position without filler rod (OAW-03)**

**Objectives:** At the end of this exercise you shall be able to

- prepare the job to the given size as per drawing
- bend the edges of the plate as per drawing
- set the job as a edge joint and tack weld them
- weld the edge joint in flat position using leftward technique
- clean and inspect the edge weld for surface uniformity.



2	ISST 50 x 2 - 150		Fe 310 - W			1.1.10
NO.OFF	STOCK SIZE	SEMI-PRODUCT	MATERIAL	PROJECT NO.	PART NO.	EX. NO.
SCALE NTS	<b>EDGE JOINT ON M.S.SHEET 2mm IN FLAT POSITION WITHOUT FILLER ROD (QAW-03)</b>				TOLERANCE ±1	TIME 15Hrs
					WLN1110E1	

## Job Sequence

- Prepare the job pieces as per drawing.
- File the edges of square and ensure thorough cleaning of the edges.
- Bend the edges of the plates to be joined at 90° to the surface.

**The length of the bent portion should be twice of the thickness of the plate.**

- Set the gas welding plant, fix nozzle No. 7 and set the gas pressure of 0.15 kg/cm<sup>2</sup> for both gases.
- Select CCMS filler rod 3mm ø for tacking and welding. (If necessary)
- Set neutral flame.
- Clean the tacks and set the job on the welding table in a flat position, over fire brick supports.

- Start the weld at right end of the job.
- Keep the blowpipe at 60° - 70°.
- Fuse the edges uniformly and proceed towards left.

**Fuse the bent edges up to the entire surface of the plate.**

- Stop at the left end, fill the crater and complete the weld.
- Extinguish the flame, cool the nozzle in water.
- Clean the welded joint and inspect for
  - Uniform width and height of bead.
  - Uniform ripples.

## Skill Sequence

### Edge joining on MS plate

**Objective:** This shall help you to

- **join the edge of the MS plate.**

Preparation: Prepare the job pieces of size 150x5x2mm by shearing and then filing.

#### **Setting and bending:**

- Bend the edges of the plates.
- Set the prepared job pieces on the welding table and tack at both ends.
- Length of the tack weld is 6 mm approximately.
- Check the alignment after tacking.

#### **Welding**

- Start the weld at the right end of the joint.
- Use leftward technique.
- Maintain uniform travel speed and feed to the flame.

- Clean the deposited bead using wire brush.

**Use all the safety apparels and gas welding goggles.**

#### **Inspection**

Inspect the quality of weld by

- Checking the finish of the job.
- Checking the uniformity of width and height of the weld bead in size.
- Checking the uniformity of ripples, fusion and complete penetration.
- Checking that the weld is free from faults such as porosity, undercut, lack of fusion etc.



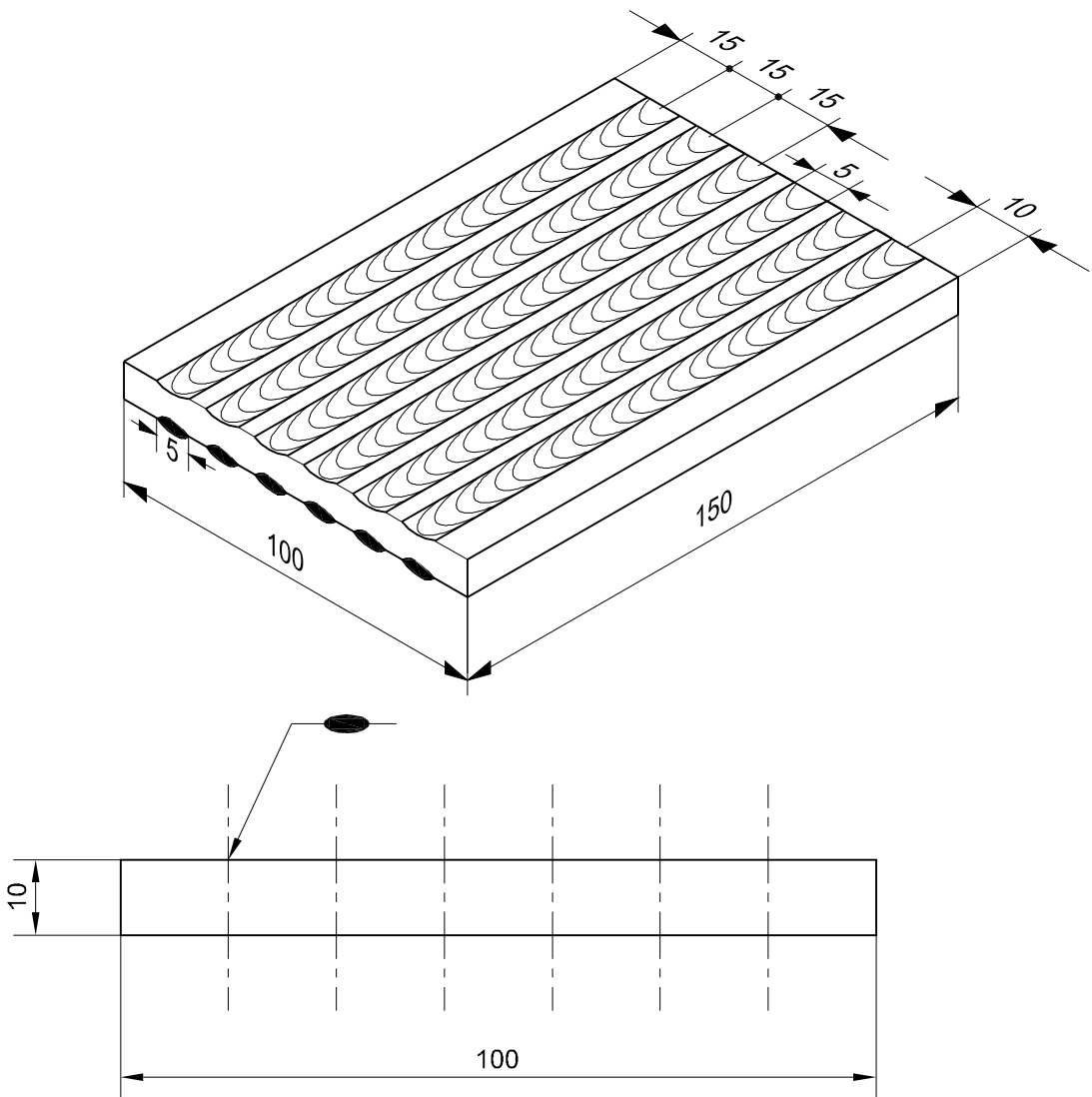
Scan the QR Code to view the video for this exercise



**Straight line beads on MS plate 10mm thick in flat position (SMAW - 02)**

**Objectives:** At the end of this exercise you shall be able to

- prepare and set job pieces for straight line beading
- select the electrode, current and polarity for depositing the weld beads
- deposit uniform straight bead in flat position by arc welding
- maintain constant arc length, electrode angle and travel speed
- restart a broken arc and fill the crater properly
- remove and clean the slag and spatter from the weld bead using a chipping hammer and wire brush
- inspect deposited beads for any surface defects.



1	100 ISF 10 - 150		Fe 310 - W			1.1.11
NO.OFF	STOCK SIZE	SEMI-PRODUCT	MATERIAL	PROJECT NO.	PART NO.	EX. NO.
SCALE NTS	<b>STRAIGHT LINE BEADS ON M.S.PLATE10mm THICK IN FLAT POSITION (SMAW-02)</b>				TOLERANCE ±1	TIME 10 Hrs
					CODE NO. WLN1111E1	

## Job Sequence

- Prepare the plates to size (as per drawing) by Hack-saw cutting and grinding.
- Clean the plate surface (job) with a stainless steel wire brush and remove the burrs by filing.
- Lay out parallel lines on both sides of the job surface as per sketch and mark with a center punch.
- Set the plate on the welding table in a flat position.
- Ensure the plate is contacting well with the welding table and the earth clamp is not loosely connected with the work table.
- Wear protective clothing (safety apparels).
- Use welding goggles.
- Ensure the filter glass of the welding shield is in good condition.
- Fix a 4 mm  $\varnothing$  M.S. electrode in the holder.
- Set the welding current to 150 to 160 amps approximately.
- Connect the electrode cable with the transformer welding machine. In case of a DC welding generator or rectifier, connect it to the negative terminal.
- Connect the earth clamp on the right extreme end of the job/work table.
- Start the welding machine.
- Strike the arc on a scrap piece for trial and observe the current setting.
- Ensure the burning of the electrode is normal and the arc is smooth.
- Readjust the welding current if necessary.
- Use a short arc.
- Deposit straight line beads on the work piece along the punched line from the left hand end to the other end.
- Hold the electrode at 70° to 80° to the line of weld. Move it along the line of weld and towards the job at uniform speed.
- Restart the bead whenever the arc is broken and ensure to fill the crater.
- Fill the crater at the end of the bead without fail.
- Remove slag from the weld bead using a chipping hammer and clean with steel wire brush.
- Use a chipping screen while Deslagging.
- Inspect deposited beads for:
  - uniform width and height
  - straightness
  - uniform ripples
  - slag inclusion
  - unfilled crater
  - porosity
  - undercut
- Repeat the exercise on the other side of the plate.

## Skill Sequence

### Straight line bead on MS plate in flat position

**Objective:** This shall help you to

- **set and weld the straight line beads on MS plate in flat position.**

Prepare a M.S. plate piece 100x150x10 using a hacksaw and file.

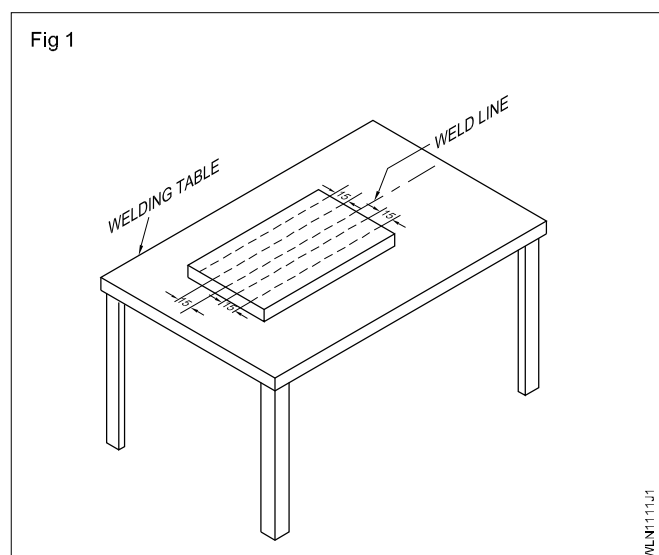
Mark straight line, punch the line keeping 15mm distance in between. (Fig 1)

Set the job on the welding table in a flat position with the punched surface facing up. (Fig 1)

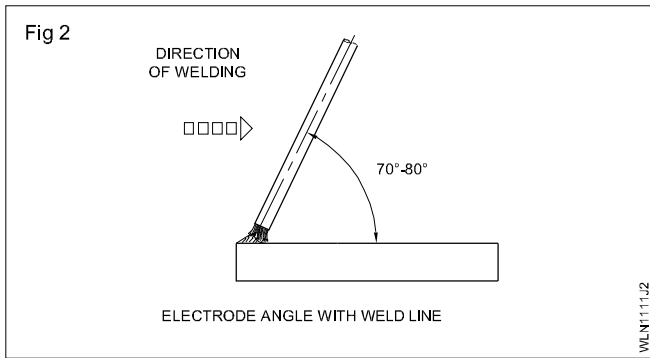
The bottom surface of the job should be perfectly clean to get good electrical contact between the job and the welding table.

Always follow the current range according to the diameter of the electrode, as given in the electrode packet by the electrode manufacturer.

Check for proper melting of the job and electrode on a scrap metal piece.



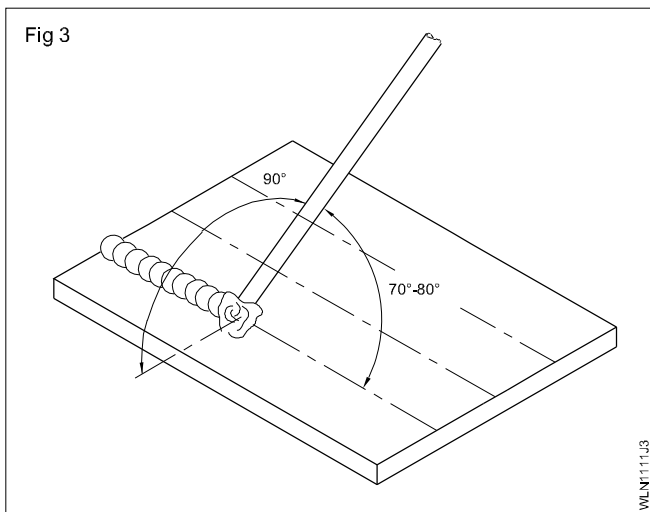
Hold the electrode at an angle of 70° to 80° with weld line/punched line. (Fig 2)



When a DC welding machine is used connecting the earth cable at the right end of the job or work table will help to deposit the weld metal at the correct place in the joint.

Deposit straight line beads taking the punched lines as a guide maintaining:

- the medium arc length (L) (i.e. equal to dia. of electrode used (d). If a DC welding machine is used then use of a short arc length will help to reduce the deviation of the molten metal from its intended path.
- correct travel speed (approximately 150 mm per minute)
- correct electrode position/angles. Fig 2 and 3

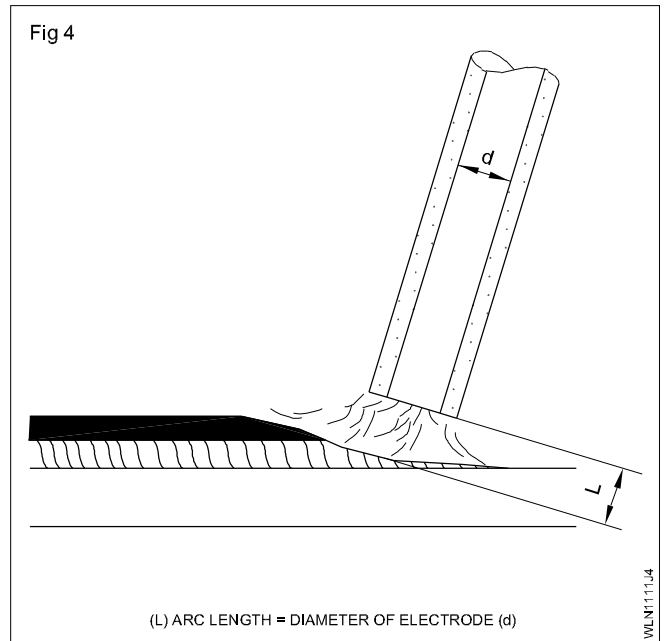


The electrode should be moved towards the job to maintain a gap between the tip of the electrode and the molten pool. (Fig 4)

Welding screen glasses should be clean enough to see the arc action on the molten pool and punched line mark.

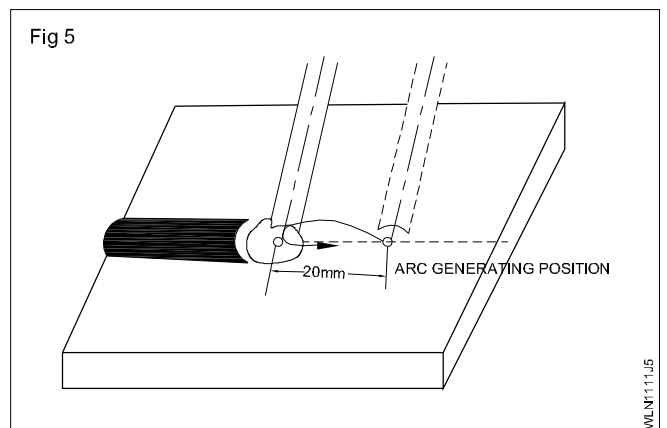
Listen to the arc's steady sharp crackling sound while welding. It indicates uniform burning of the electrode.

Adjust the travel speed by watching the electrode melting rate and flowing through the molten pool to form the deposited metal. The uniform travel speed of the electrode along and towards the line of the weld gives a uniform bead.

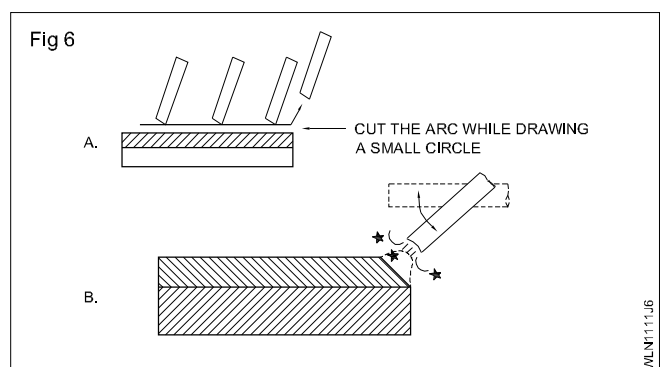


Whenever the arc is broken a depression called crater is formed at the breaking point and this crater has to be filled first while restarting the arc. So clean the crater and generate an arc at about 20mm ahead of the crater and return to the crater at a faster rate.

Build the deposit so that it fills the crater, then move the electrode ahead. Fig 5.



Also after completion of each bead fill the crater as follows. Fig 6

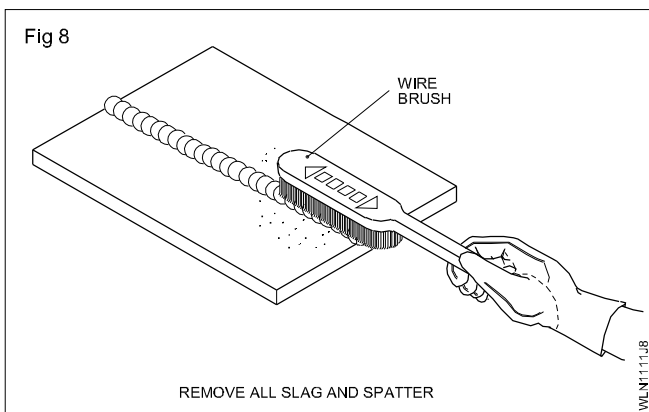
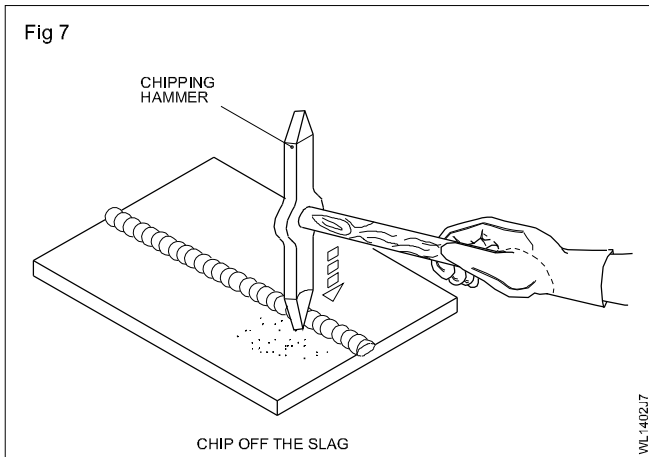


Build the deposit on the crater so that it is the same level as the welding bead.

- Let the arc length be shorter at the end of the run and draw a small circle 2 to 3 times.
- Repeat Off and On the arc at the end.

Fill the crater. Fig 6

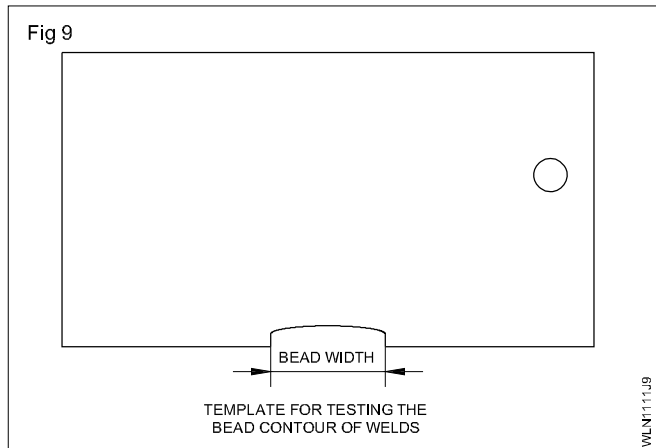
Remove the slag and spatters from the weldment using a chipping hammer and wire brush, so that the metal surface of the bead is exposed for checking for any defects. (Figs 7 and 8)



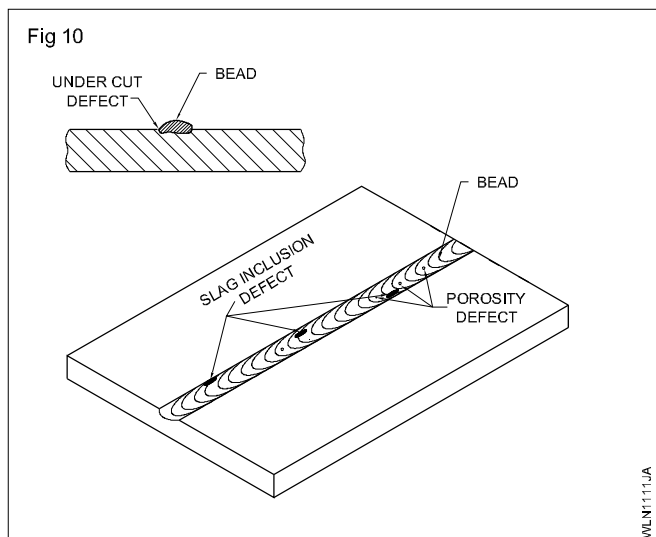
Determine the causes for the above weld defects and use the remedial/prevention methods in further deposits.

Check the deposited beads and note any variation in the:

- width and height using a template Fig 9.



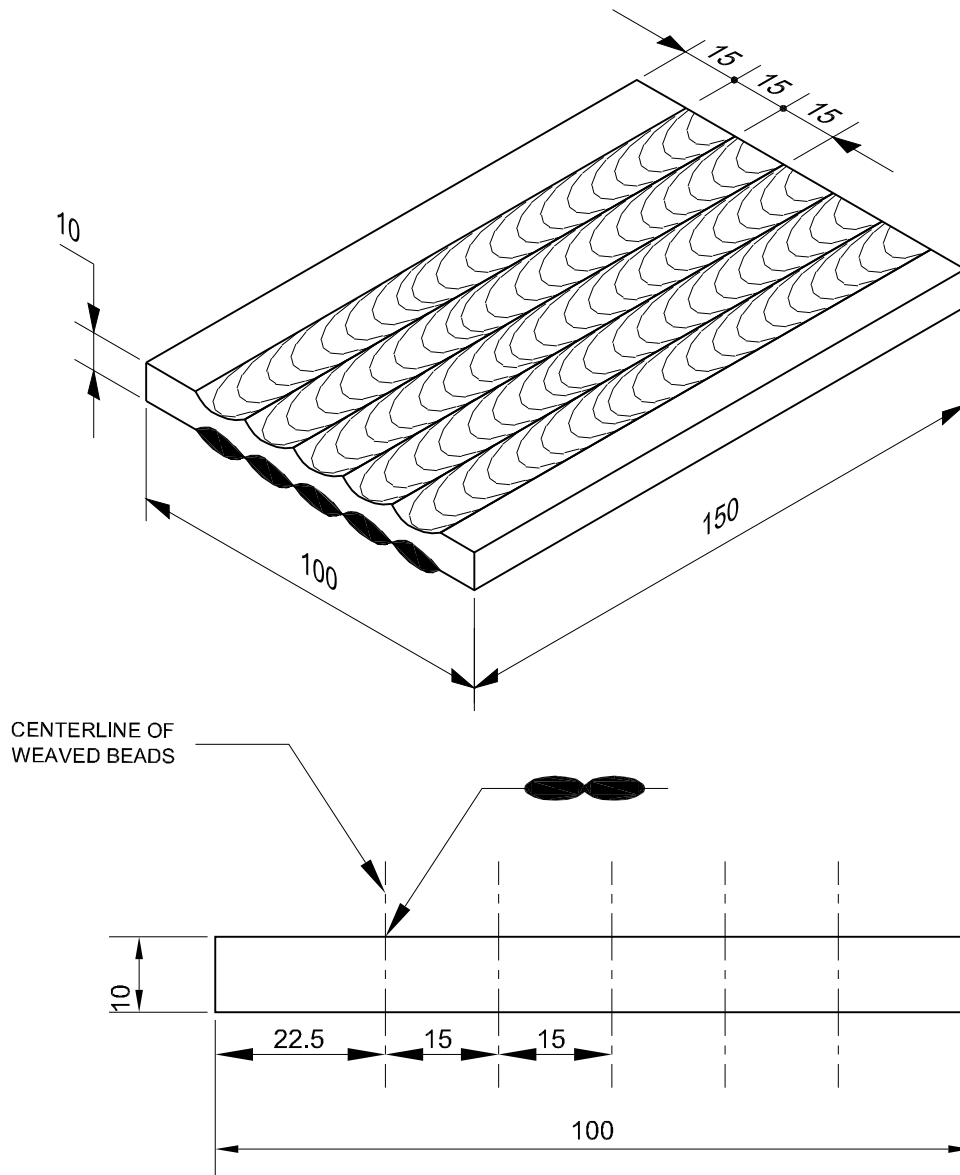
- depth of fusion
  - straightness of the run
  - check for surface defects such as slag inclusion, surface porosity, undercut, improper bead profile etc.
- Fig 10



**Weaved beads on MS plate 10mm thick in flat position (SMAW-03)**

**Objectives:** At the end of this exercise you shall be able to

- prepare and set the plate pieces for depositing weaved beads
- select and set the electrode, current, polarity
- deposit uniform beads by weaving the electrode in flat position
- maintain the required arc length, electrode travel speed and angle
- restart and end the bead properly without crater defect
- inspect to ensure the welds are free from defects and of specified size.



1	100 ISF 10 - 150		Fe 310 - W			1.1.12
NO.OFF	STOCK SIZE	SEMI-PRODUCT	MATERIAL	PROJECT NO.	PART NO.	EX. NO.
SCALE NTS		<b>WEAVED BEADS ON M.S PLATE 10mm THICK IN FLAT POSITION (SMAW-03)</b>			TOLERANCE ±1	TIME 15Hrs
					CODE NO. WLN1112E1	

## Job Sequence

- Prepare the job to size as per the given drawing.
- Ensure the job piece is free from oil, grease, paint, dirt etc.
- Clean the job surface with a steel wire brush and by grinding the edges.
- Mark parallel lines on the job surface as per drawing for depositing weaved beads and punch.
- Set the work piece (job) on the welding table in a flat position.

### **Wear protective clothing (safety apparels).**

- Inspect the welding screen glasses for spatters and for suitable shade number.
- Select 4mm  $\varnothing$  medium coated M.S. electrode. (BIS Code:ER4211)
- Set the welding current between 150 - 160 amps.
- Observe the electrode burning rate on a scrap piece and re-adjust the current, if necessary.
- Deposit the weaved beads on the work piece between the punched lines from one end to the other.

- Restart the weld whenever the arc is put off or when changing electrode or otherwise.
- Stop weld in the end and fill up the crater.
- Deslag the weld bead using a chipping hammer and clean with a steel wire brush.

Use chipping goggles and tongs during Deslagging.

- Inspect the deposited weaved beads for:
  - uniform width and height
  - straightness of beads
  - uniform ripples
  - overlap on sides of weld
  - external weld defects like undercut, porosity, slag inclusion etc.
  - unfilled crater
  - restarting defects.
- Repeat the exercise till you produce uniform weaved beads, with correct restarts and stops.

## Skill Sequence

### Deposit weaved beads in flat position

**Objective:** This shall help you to

- **deposit weaved bead on 10mm MS plate at required place.**

Wider or weaved beads are required while welding deep groove joints (Fig 1) and multi-pass fillet welds used while welding thicker plates and pipes.

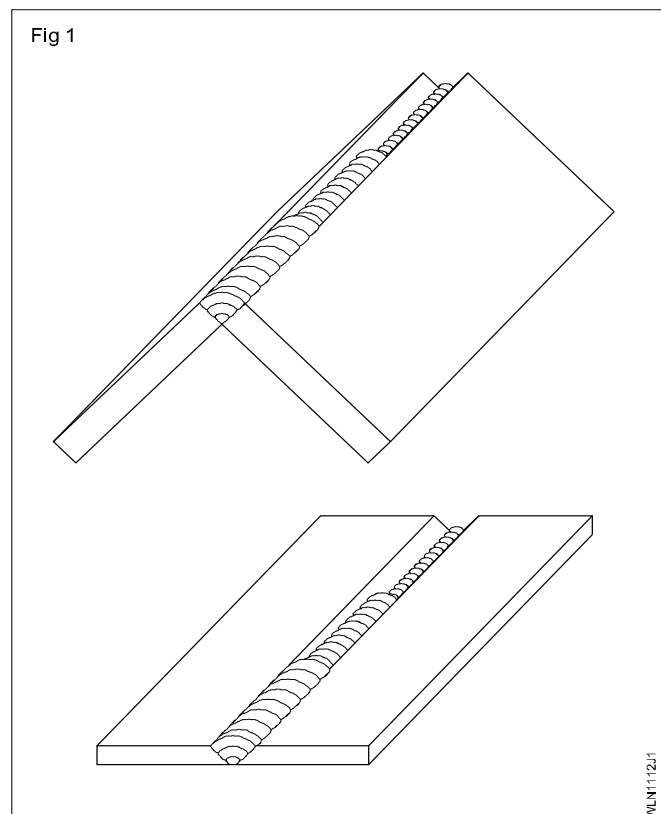
#### **Deposition of weaved beads in flat position**

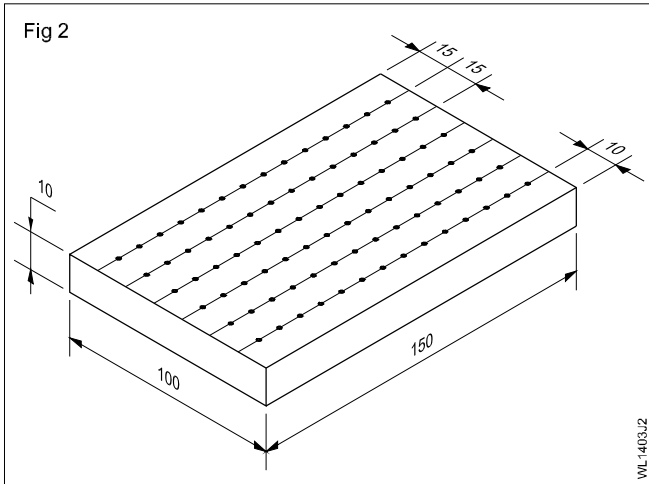
Prepare M.S. plate piece 150×100×10mm with punched lines for laying weaved beads. (Fig 2)

Ensure 150 - 160 amps current setting for a 4.00 mm  $\varnothing$  medium coated M.S. electrode. For selecting the current to be used for different types and sizes of electrodes, refer the electrode packet on which the details are given.

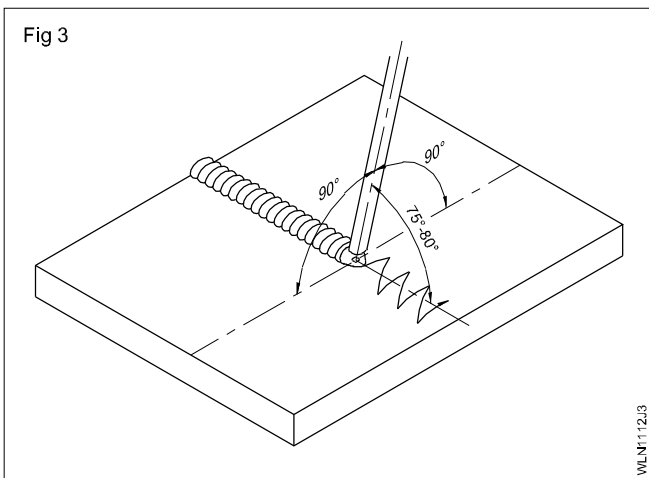
Position the electrode with the weld line at an angle of 75° - 80°. Fig 3.

Position the electrode with the adjoining plate surface at an angle of 90° giving side-to-side weaving motion using the arm movement. Avoid using wrist movement for electrode weaving.

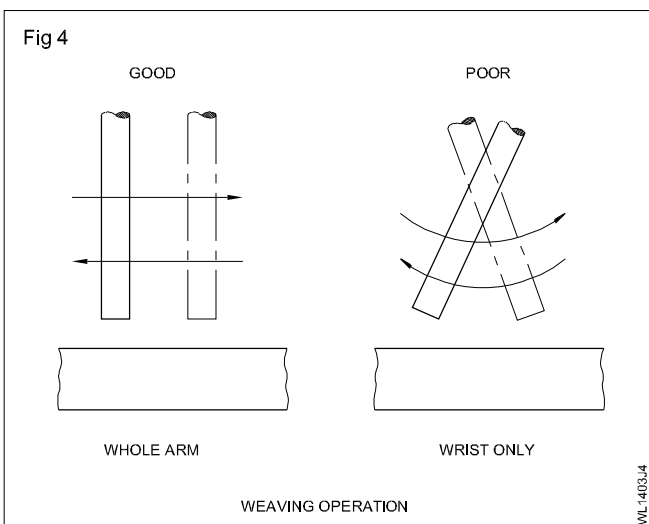




Deposit the weaved beads between the punched lines by:  
Positioning the electrode correctly (as shown in the Fig 3)



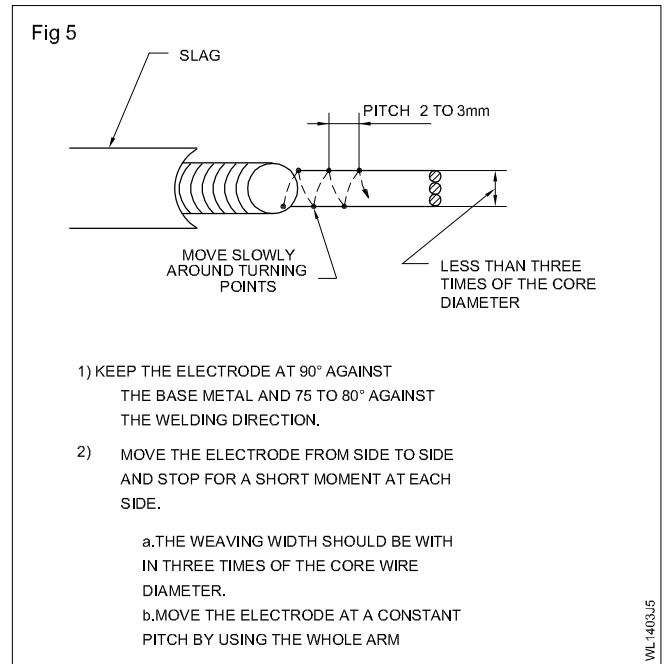
Weaving the electrode side-to-side. (Fig 4)



Restrict the weaving motion to three times the electrode diameter i.e. 10 to 12mm for 4mm $\varnothing$  electrode.

Advance the bead on each weave by not more than 2 to 3 mm, so that the light, thin, molten slag will always be kept away from the molten pool of metal. Fig 5.

Advancing the bead too far ahead will result in slag inclusion and poor appearance.

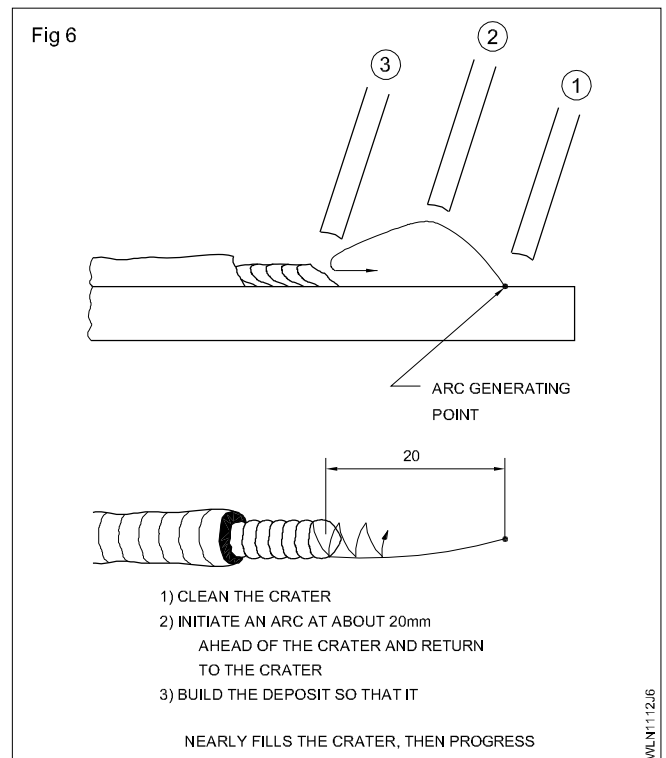


### Restarting of bead

To ensure a good restart, proper fusion and fill up at the crater, proceed as follows.

Remove the slag about 25 mm from the end of the crater.

Restart with a long arc at the forward edge of the crater. (Fig 6)



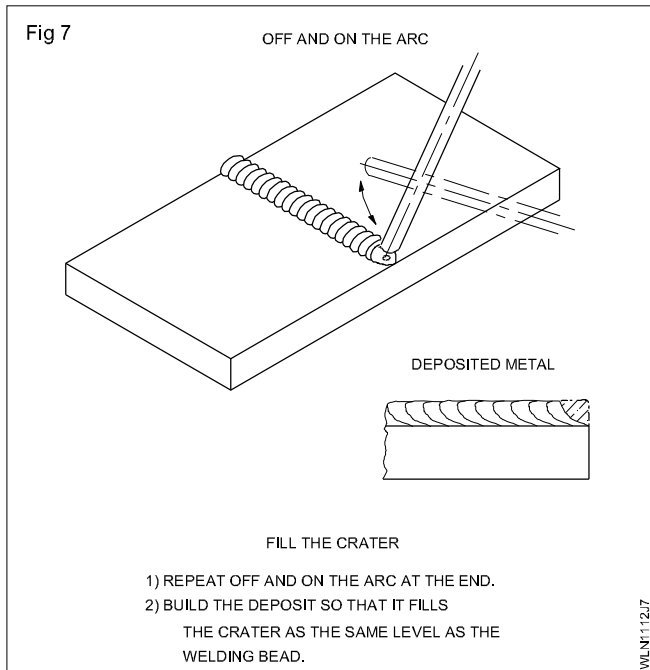
Move the arc slowly across the crater reducing the arc length and fill the crater.

Start forward travel at the normal rate with medium arc length.

## Ending the bead

At the end of each weld bead fill up the crater as follows.

Stop the forward movement of the electrode at the end of the weld. (Fig 7)

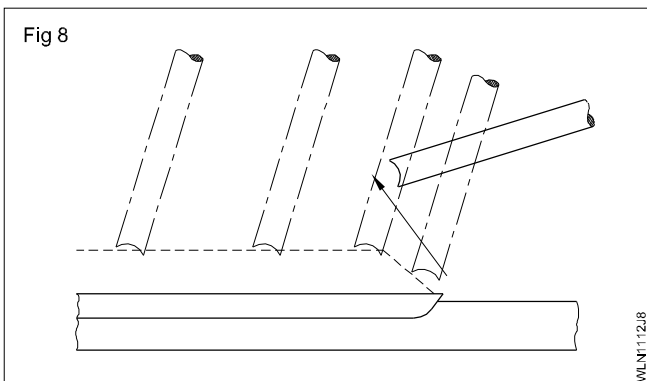


Change the angle of the electrode.

Move back along the weld about 15-20 mm.

Hold for 2 to 3 seconds to fill the crater.

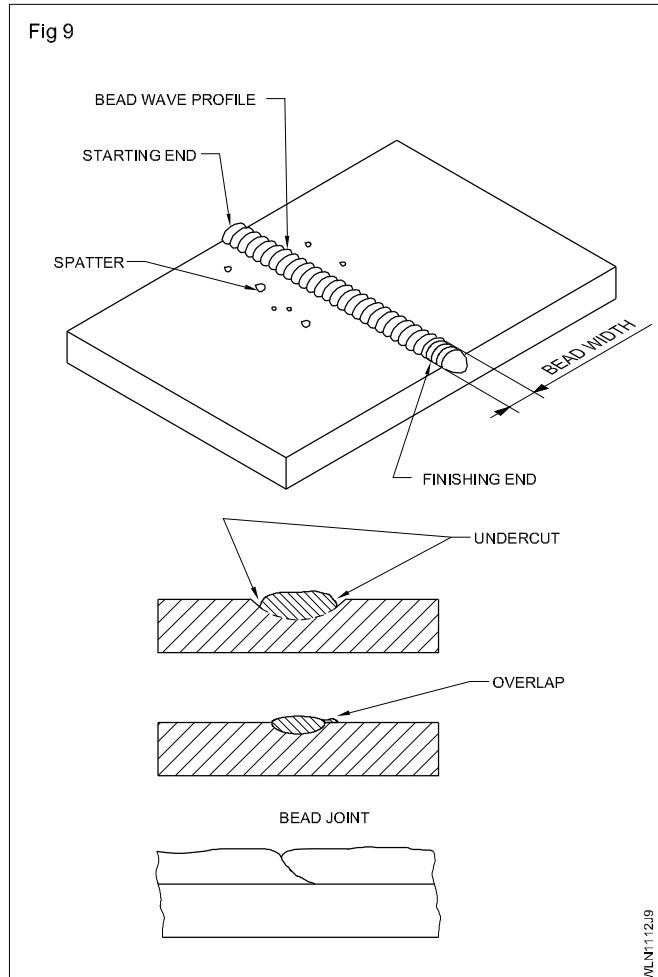
Break the arc quickly. (Fig 8)



Inspect the beads.

Check for

- Bead form (width, reinforcement and wave profile). Fig 9
- Undercut and overlap porosity, slag inclusion and finish. Fig 9

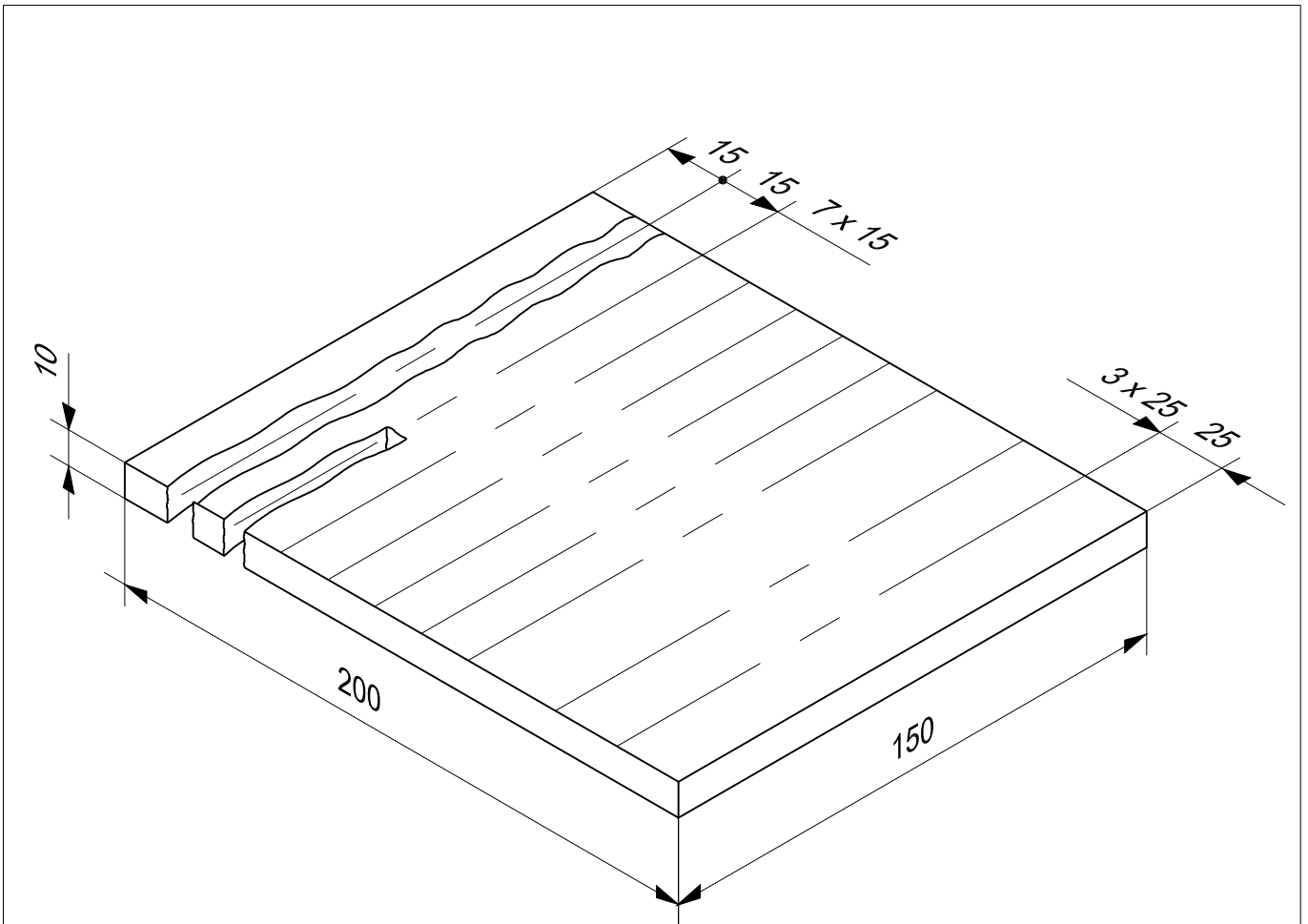




**Setting of Oxy - Acetylene and make straight cuts (free hand)**

**Objectives:** At the end of this exercise you shall be able to

- set the work piece for a straight cutting
- adjust the gas cutting flame
- gas cut along a straight line by hand
- observe safety while cutting with gas
- clean and inspect the gas cut surface.



1	100 ISF 10x100x200mm	-	Fe310-W	-	-	1.1.13
NO.OFF	STOCK SIZE	SEMI-PRODUCT	MATERIAL	PROJECT NO.	PART NO.	EX. NO.
SCALE 1:2	<b>SETTING UP OF OXY - ACETYLENE AND MAKE STRAIGHT CUTS (FREE HAND)</b>				DEVIATIONS	TIME 2hrs
					CODE NO. WLN1113E1	

## Job Sequence

- Wear complete safety apparel.
- Set the gas welding plant with a cutting blowpipe.
- Attach the correct nozzle according to the thickness of the metal.
- Adjust the gas pressure of acetylene and cutting oxygen according to the thickness of the metal and the cutting nozzle.
- Clean the surface to be cut.
- Punch a straight line.
- Adjust proper cutting flame.
- Hold the cutting blowpipe at 90° to the cut line and plate surface.
- Hold at one end of the plate on the punch line up to cherry red hot.

**Keep a distance of about 5mm between the work piece and the nozzle.**

- Release the cutting oxygen and observe the cutting action.
- Move the cutting blowpipe towards the other end, following the procedure line.

**Maintain a correct speed and distance of the nozzle.**

- Close the cutting oxygen and shut off the flame on the completion of the cut.
- Clean the cut and inspect for its accuracy.
- Repeat the exercise till a good and smooth cut is achieved.

## Skill Sequence

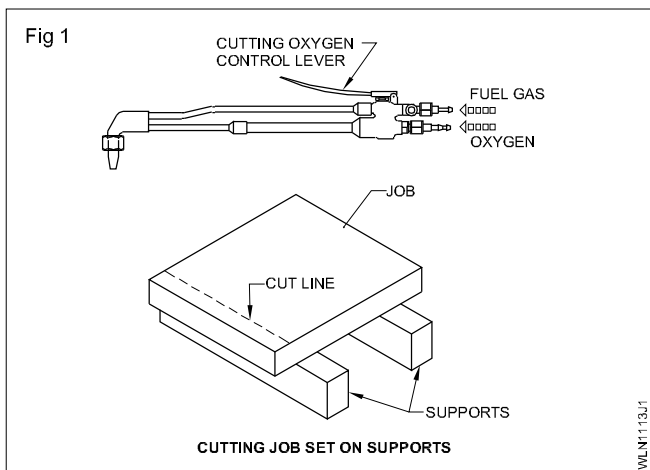
### Straight cutting along by hand

**Objectives:** This shall help you to

- set an oxy-acetylene plant for gas cutting
- gas cut in a straight line by hand
- inspect the faults in a gas cut.

**Setting the gas cutting plant:** Set the oxy-acetylene plant and connect the cutting blowpipe.

**Setting the job for cutting (Fig 1)**



Set the job for cutting on a rigid surface.

Provide overhang so that the parting piece is free to fall.

Ensure the underside of the cut line is free from any obstruction.

Wear safety apparel while gas cutting.

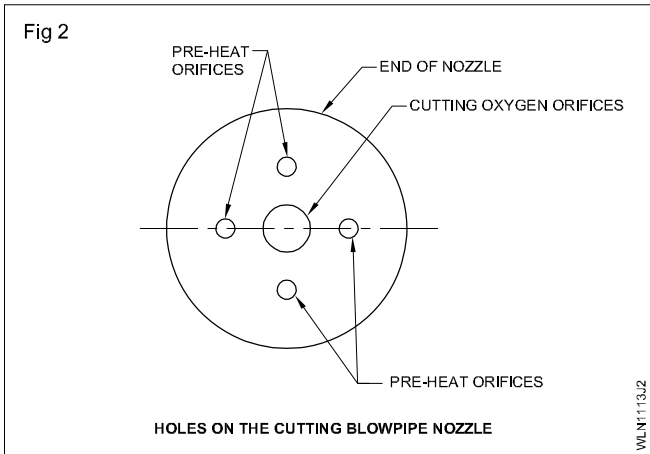
### Adjusting the cutting flame

Select the cutting nozzle and set the gas pressure as per the cutting job thickness. (Table 1)

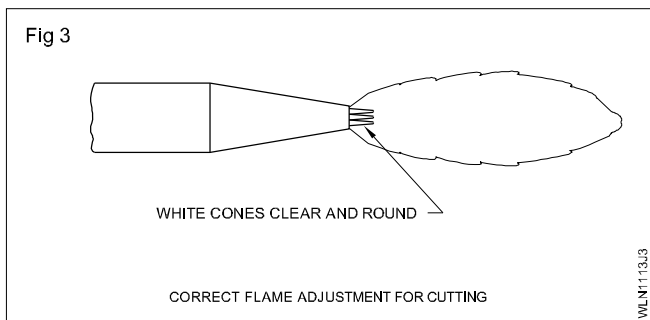
Set the cutting nozzle in the blowpipe correctly. (Fig 2)

**TABLE 1**  
**Data for cutting**

Diameter of cutting oxygen orifice nozzle	Thickness of steel plate	Cutting oxygen Pressure
(1) mm	(2) mm	(3) kg/cm <sup>2</sup>
0.8	3-6	1.0-1.4
1.2	6-19	1.4-2.1
1.6	19-100	2.1-4.2
2.0	100-150	4.2-4.6
2.4	150-200	4.6-4.9
2.8	200-250	4.9-5.5
3.2	250-300	5.5-5.6



Adjust the neutral flame for preheating. (Fig 3)



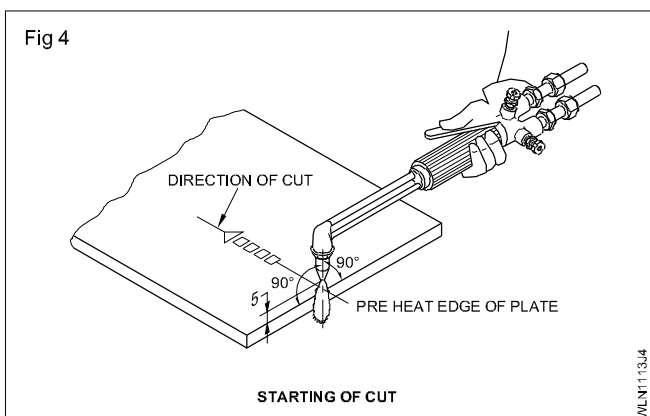
**Ensure that the flame adjustment is not disturbed while operating the control lever for cutting oxygen.**

### Straight cutting

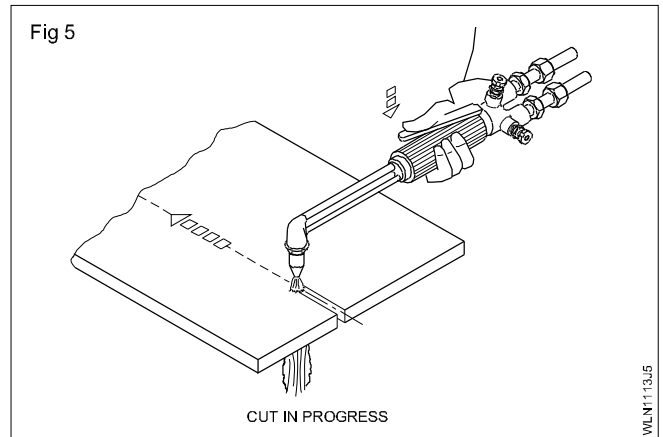
Hold the cutting blowpipe at 90° with the plate surface, and cut along the line (Fig 4)

Preheat the starting point to red heat. (Fig 4)

**Keep the distance between the work piece and the nozzle about 5mm to avoid backfire. (Fig4)**



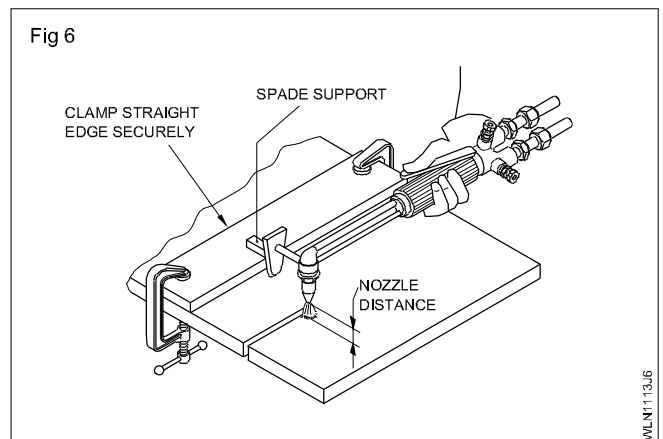
Release the extra oxygen, observe the cutting action and start travelling along the punched line at a uniform speed. (Fig 5)



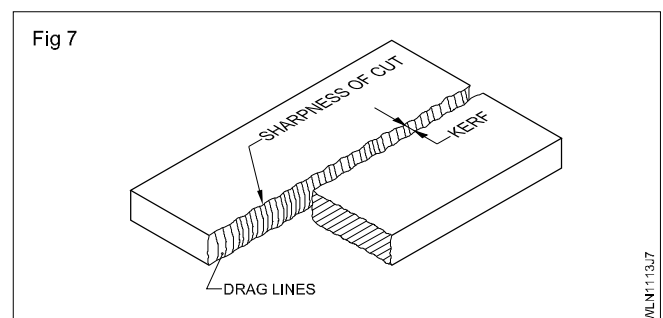
**While gas cutting ensure**

**Straight travel of the cutting blowpipe without side-to-side movement and correct nozzle position with the plate surface till the cutting oxygen valve is fully open.**

If possible, fix the straight edge to the plate, and also the spade support to ensure a straight cut (Fig 6) and to maintain correct nozzle distance.



**Inspection of gas cut (Fig 7)**



Clean the gas cut with a chipping hammer, chisel and wire bunch.

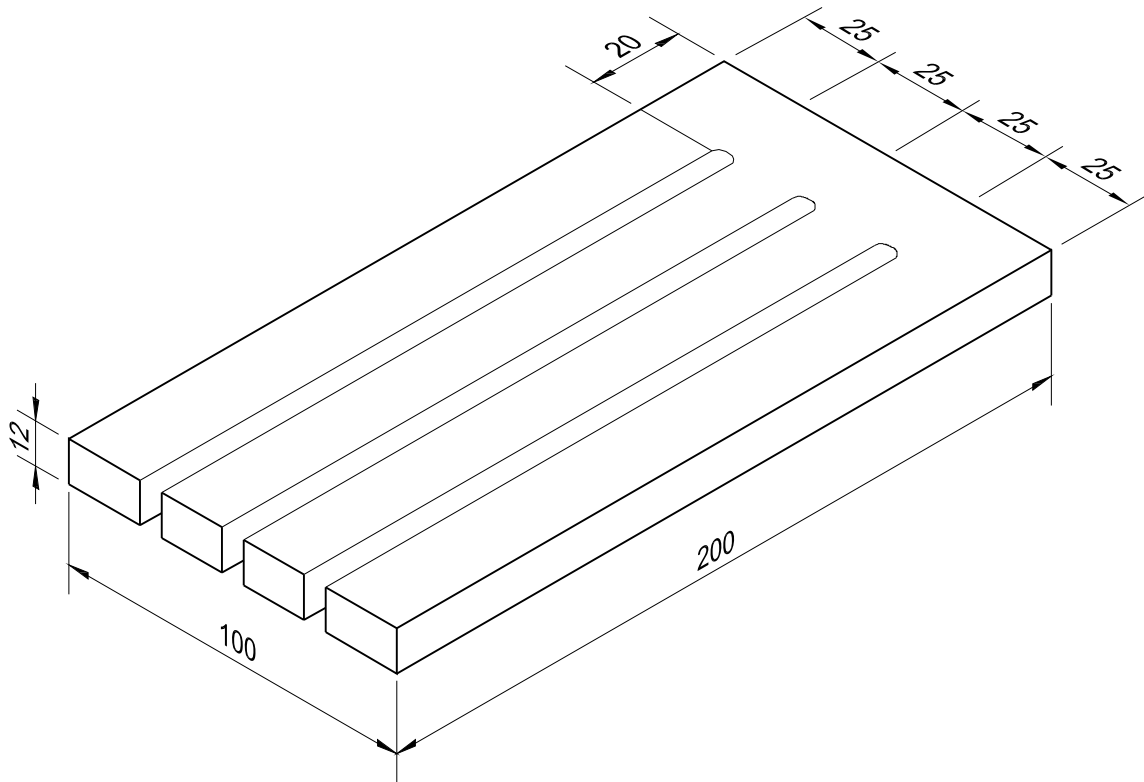
**Inspect for uniform**

- Smooth cut or drag lines
- Straightness of cut
- Sharpness of cut
- Width of cut.

**Perform making straight line cutting of MS plate 10mm thick by gas accuracy within  $\pm 2\text{mm}$**

**Objectives:** At the end of this exercise you shall be able to

- set the work pieces for a straight cutting
- adjust the gas cutting flame
- gas cut along a straight line by hand
- observe safety while cutting with gas
- clean and inspect the gas cut surfaces.



2	100 ISF 12-200	-	Fe310-W	-	-	1.1.14
NO.OFF	STOCK SIZE	SEMI-PRODUCT	MATERIAL	PROJECT NO.	PART NO.	EX. NO.
SCALE 1:2	<b>PERFORM MAKING STRAIGHT LINE CUTTING OF M.S PLATE 10mm THICKNESS BY GAS. ACCURARY WITH IN <math>\pm 2\text{mm}</math></b>				DEVIATIONS	TIME 4hrs
					CODE NO. WLN1114E1	

# Job Sequence

## Making straight cuts

- Wear all safety clothing.
- Set the gas welding plant with a cutting blowpipe, and cutting oxygen regulator.
- Fit the correct cutting nozzle according to the thickness of the metal to be cut (for M.S. plate 10mm thickness use 1.2mm dia. orifice cutting nozzle)
- Adjust both oxygen and acetylene gas pressure according to the cutting nozzle size. (Oxygen 1.6 kg/sq.cm and acetylene 0.15 kg/sq.cm)

**While adjusting the pressure, keep the cutting blowpipe valves open.**

- Take 200x150x10 thick plate, clean, mark and punch the straight lines on the plate 25mm apart.
- Set the neutral flame.
- Wear the gas welding goggles.
- Hold the blowpipe at an angle of 90° between the line of cut and the cutting nozzle axis and between the nozzle and the surface of the plate.
- Heat one end of the punched line up to cherry red hot condition.

- Keep the distance between the work piece and the tip of the nozzle about 5mm.
- Place the preheat cone approximate 1.6mm above the plate.
- Move the flame in circle a little larger than the tip size. When metal is heated to Cherry red, move the tip to the edge of the plate.
- Operate the cutting oxygen lever immediately and move the torch slowly along cutting direction.
- Maintain correct torch speed and distance between the plate surface and the nozzle up to the end of the cut.
- If long plates are to be cut, to get a good straight gas cut surface, clamp a straight edged flat parallel to the line of cut and use a spade guide attached to the cutting torch. Move the torch uniformly along the clamped flat and pressing the spade guide against the flat.
- On completion of the cut release the cutting oxygen lever and shut off the flame.
- Clean the cut surface by wire brush after chipping off any slag sticking to the cut edge.

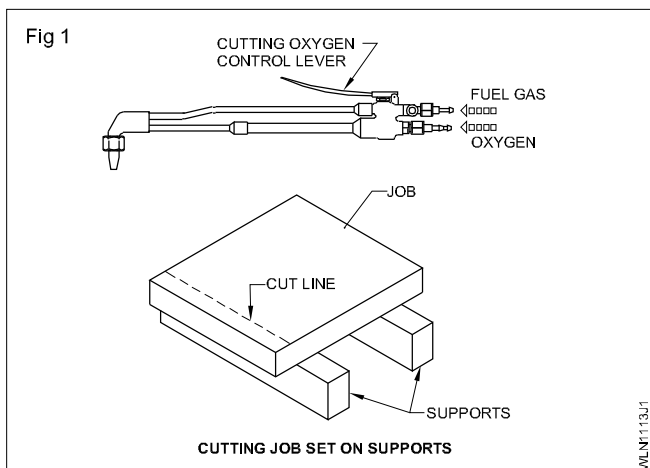
# Skill Sequence

## Gas cutting

**Objectives:** This shall help you to

- set the gas cutting plant
- cut the material to the required size.

**Setting the gas cutting plant:** Set the oxy-acetylene gas cutting plant in the same way as was done for welding and connect the cutting blowpipe in the place of the welding blowpipe. (Fig 1) Also change the oxygen welding regulator with oxygen cutting regulator.



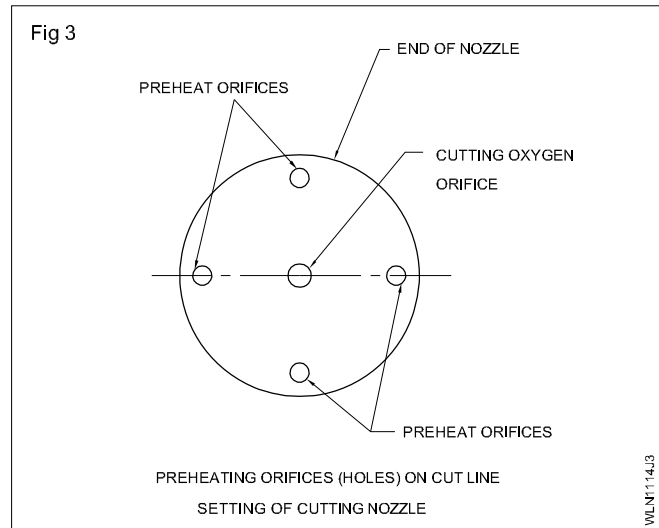
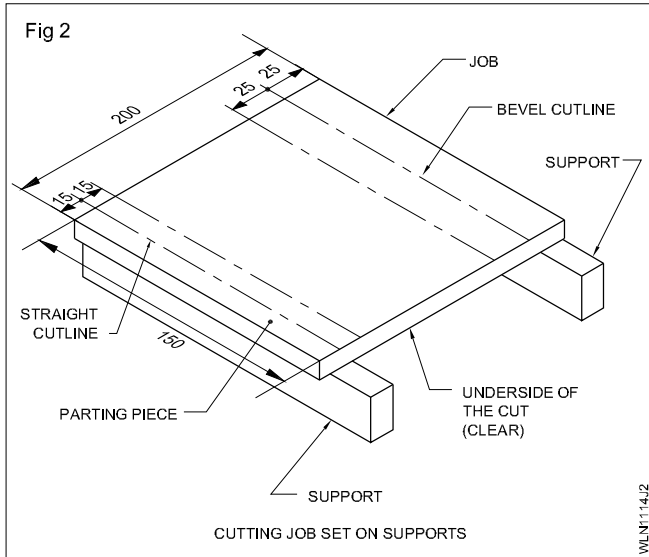
**Setting the job for straight line cutting (Fig 2):** Mark and punch 7 straight lines on the plate 15 mm apart for a straight line cut and 3 lines 25mm apart for bevel cutting on other edge.

Set the job on the cutting table so that the parting piece is free to fall.

**Ensure that the underside of the cutting line is clear and no combustible materials are lying nearby.**

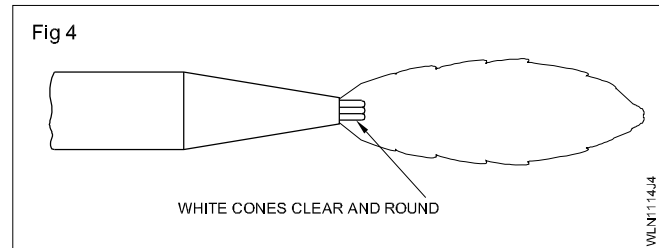
**Adjusting cutting flame:** Select the cutting nozzle and set the gas pressure as per the cutting job thickness. (Table 1)

The bevel thickness will be more for bevel cut, when compared with a square cut for same thickness.



**TABLE 1**  
**Data for cutting**

Diameter of cutting oxygen orifice nozzle	Thickness of steel plate	Cutting oxygen Pressure
(1) mm	(2) mm	(3) kg/cm <sup>2</sup>
0.8	3-6	1.0-1.4
1.2	6-19	1.4-2.1
1.6	19-100	2.1-4.2
2.0	100-150	4.2-4.6
2.4	150-200	4.6-4.9
2.8	200-250	4.9-5.5
3.2	250-300	5.5-5.6



Ensure that the flame adjustment is not disturbed while operating the cutting oxygen lever.

**Straight line cutting:** Keep the hand cutting blowpipe at 90° angle with the plate surface and start cutting a straight line. (Fig 5)

Acetylene pressure should be 0.15 kg/cm<sup>2</sup> for all thickness of plates.

Select ø 1.2 mm (orifice) cutting nozzle for cutting a 10mm thick plate.

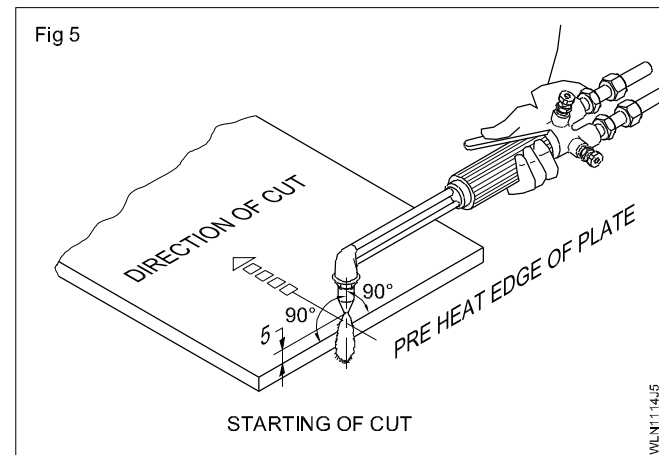
Set 1.6 kg/sq.cm pressure for the cutting oxygen and 0.15 kg/sq.cm pressure for the acetylene gas.

Ensure safety apparel is worn.

Fix the cutting nozzle into the cutting blowpipe correctly. (Fig 3)

Check for leakage in the blowpipe connections of oxygen and acetylene gas lines.

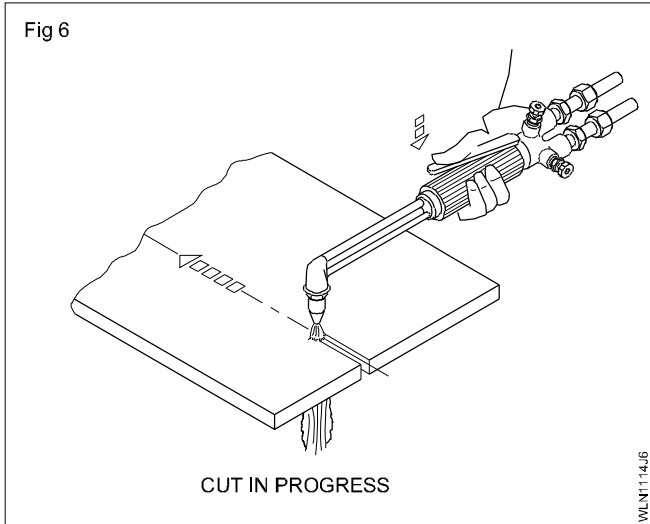
Adjust the neutral flame for preheating. (Fig 4)



Preheat the starting point to red heat before pressing the cutting oxygen lever. (Fig 5)

Keep the distance between the work piece and the nozzle about 5 mm to avoid backfire. (Fig 5)

Release the cutting oxygen by pressing the cutting oxygen control lever and start the cutting action and move the blowpipe along the punched line with uniform speed. (Fig 6)

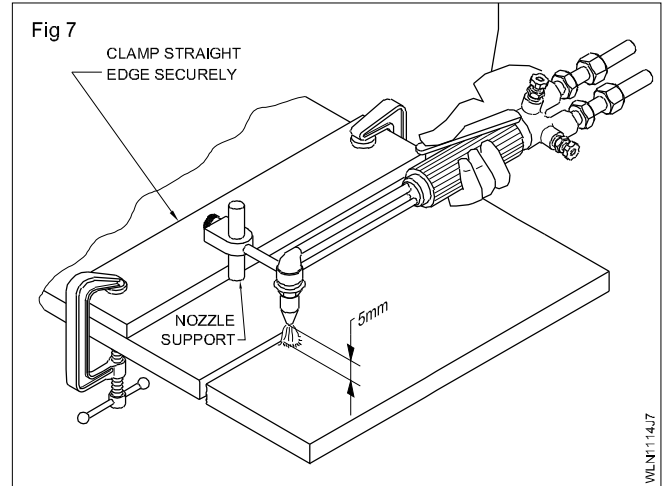


Ensure straight travel without any side-to-side movement.

The nozzle angle is 90° with the plate surface till the completion of cut.

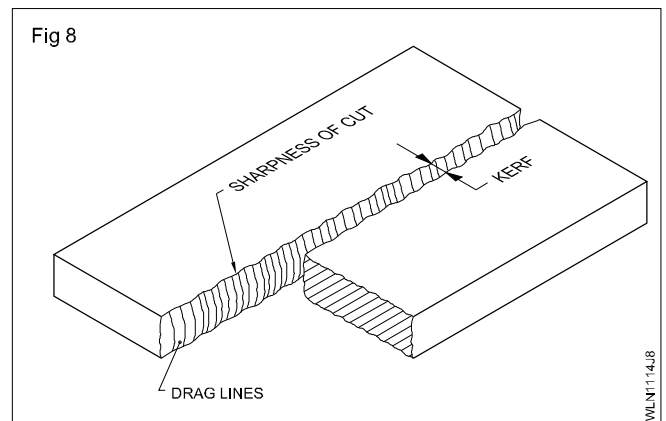
Open the cutting oxygen valve fully.

If possible fix a straight edge or template to the plate and fix a support to the cutting nozzle so as to ensure constant distance between the tip of the nozzle and the plate surface and maintain a uniform straight cut. (Fig 7)



Inspect the cutting for

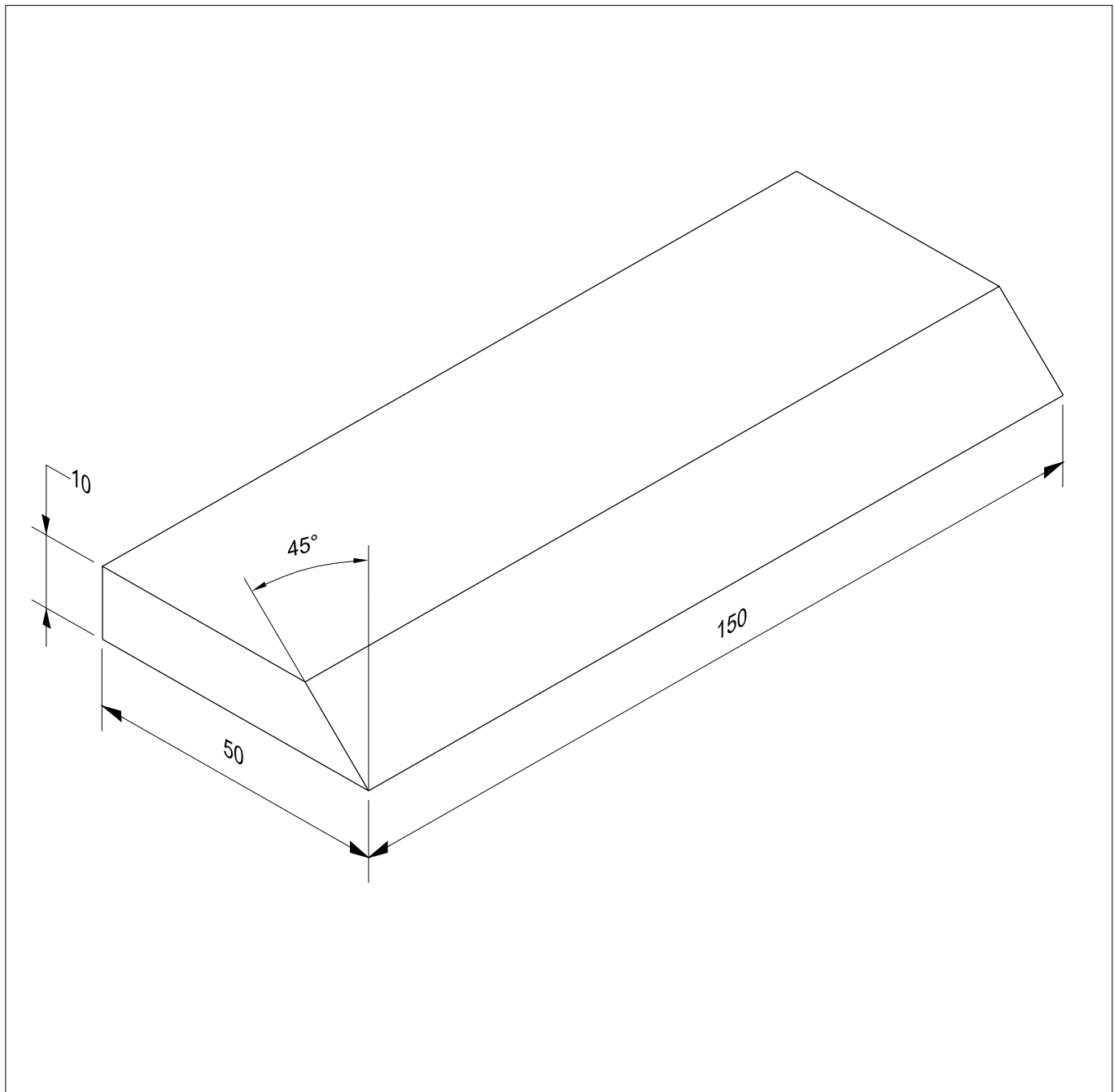
- uniform and smooth cut or drag line
- straightness, sharpness
- width of the cut (Kerf) Fig 8

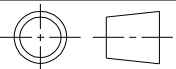


**Beveling of MS plates 10mm thick cutting regular geometrical shapes and irregular shapes cutting chamfers by gas cutting**

**Objectives:** At the end of this exercise you shall be able to

- set the work piece for bevel cutting
- cut bevel by hand using gas cutter
- clean and visually inspect the gas cut.



2	50 ISF 10-150	-	Fe310-W	-	-	1.1.15
NO.OFF	STOCK SIZE	SEMI-PRODUCT	MATERIAL	PROJECT NO.	PART NO.	EX. NO.
SCALE : NTS	<b>BEVELING OF M.S PLATE 10mm THICK CUTTING REGULAR GEOMETRICAL SHAPES AND IRRUGULAR SHAPES CUTTING CHAMPERS BY GAS CUTTING</b>				DEVIATIONS	TIME 7h
					CODE NO. WLN1115E1	



## Job Sequence

- Wear safety apparel.
- Clean the surface to be cut.
- Set the gas welding plant and fix the cutting blowpipe.

**Ensure the cutting nozzle is according to the thickness of the metal.**

- Adjust the gas pressure of acetylene and the cutting oxygen.

**Ensure the pressure setting as per the metal thickness and size of the cutting nozzle.**

- Mark and punch the plate at the required bevel angle.
- Adjust a proper cutting flame.
- Hold the cutting blowpipe at the proper bevel angle to be cut.

- Heat at one end of the plate on the punch line up to cherry red hot.
- Release the cutting oxygen, and observe the cutting action.
- Move the cutting blowpipe towards the other end, following the punched line slowly and steadily at the required angle.

**Maintain a correct speed and distance of the nozzle.**

- Close the cutting oxygen and extinguish the flame on the completion of the cut.
- Clean the cut, and inspect for its accuracy.
- Repeat the exercise till you achieve a good and smooth cut.

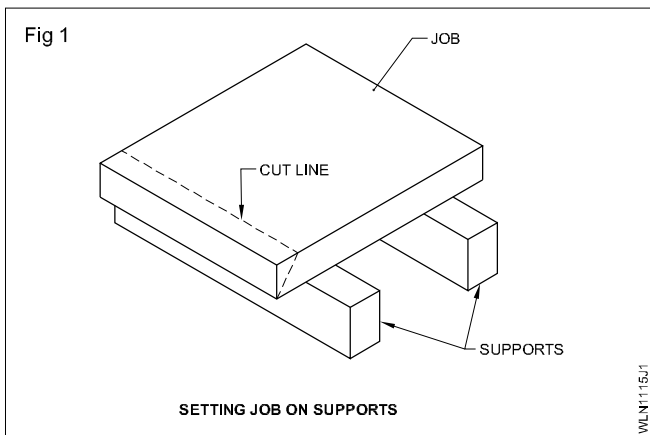
## Skill Sequence

### Bevel cutting by hand (Oxy-acetylene)

**Objectives:** This shall help you to

- set the work piece for bevel cutting
- gas cut bevel surfaces by hand
- inspect the bevel cut.

#### Setting the job (Fig 1)



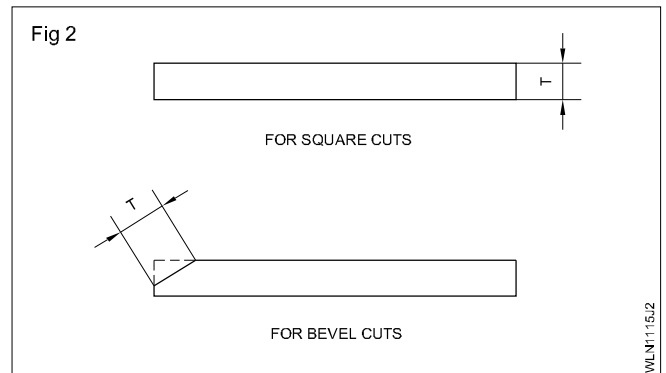
Set the job on a rigid table.

**Ensure the underside of the cut line is clear.**

Adjustment of the cutting flame.

Select a cutting nozzle as per the length of the bevel. (Fig2)

Set the cutting nozzle in the blowpipe and adjust the neutral flame for pre-heating.



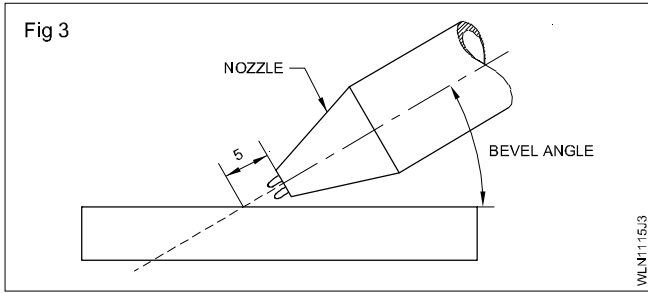
**Ensure that the flame adjustment is not disturbed while operating the cutting oxygen lever.**

#### Bevel cutting

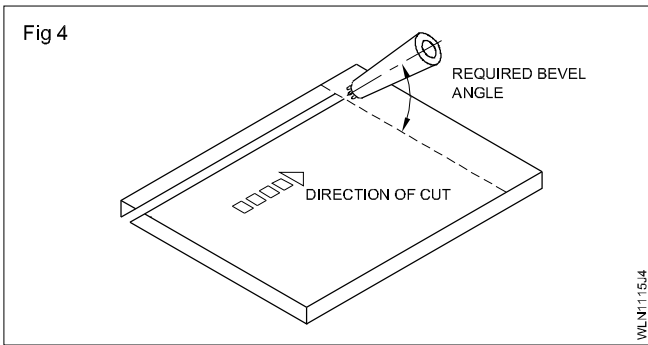
Hold the cutting blowpipe (nozzle) at the required bevel angle. (Fig 3)

Preheat the starting point to a cherry red color.

**Distance between the work piece and the nozzle tip should be about 5mm to avoid backfire. (Fig 3)**

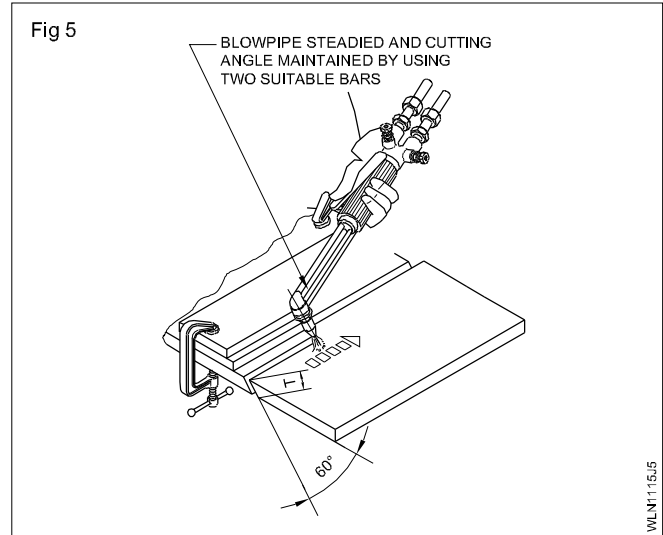


Release extra oxygen, observe the cutting action and start travelling along the punched line with a uniform speed (Fig 4) and steady hand.



**The cutting speed should be less than required for the straight cut for the same thickness.**

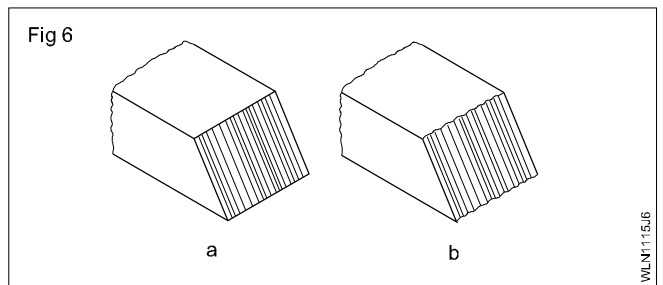
If possible, fix suitable straight bars to the cutting job to ensure a straight cut and angle maintenance. (Fig 5)



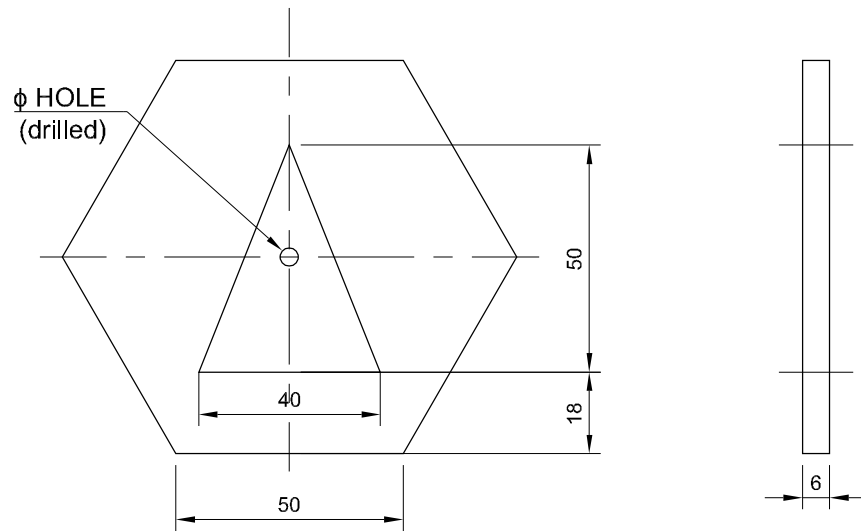
### Inspection of bevel cut

Clean the cut and inspect the cutting quality

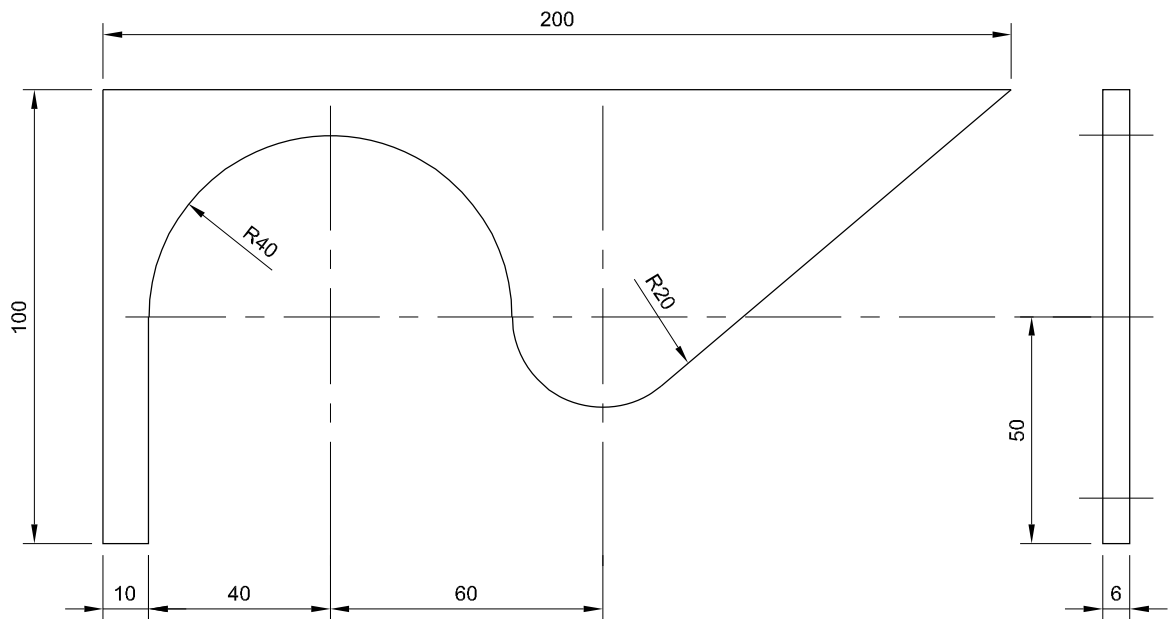
A good quality cut is indicated by a straight top edge and extremely smooth-cut face. (Fig 6a) Poor quality gouging is a common defect in gas cutting. (Fig 6b) This is caused by excess speed or too mild a heating flame.



TASK-2



TASK-3

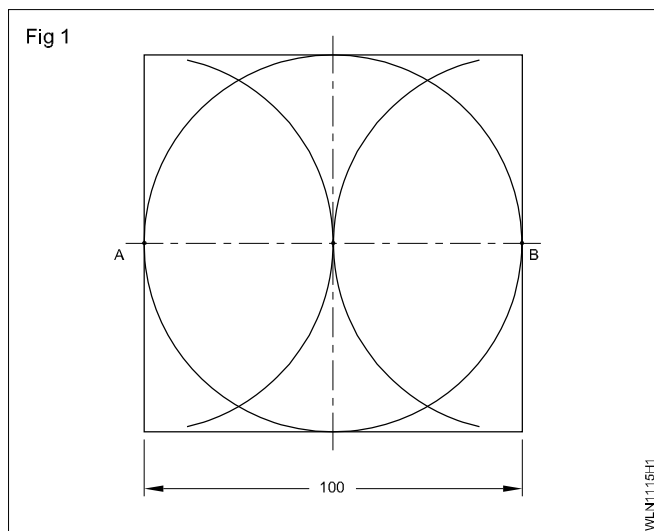


1	200 ISF 6-100	-	Fe 310	-	TASK-3	
1	100 ISF 6-30	-	Fe 310	-	TASK-2	1.1.15
NO.OFF	STOCK SIZE	SEMI-PRODUCT	MATERIAL	PROJECT NO.	PART NO.	EX. NO.
SCALE : 1:1	<b>MARKING AND GAS CUTTING OF GEOMETRICAL SHAPES AND IRREGULAR SHAPE</b>				DEVIATIONS ±0.04	TIME
					CODE NO. WLN1115E2	

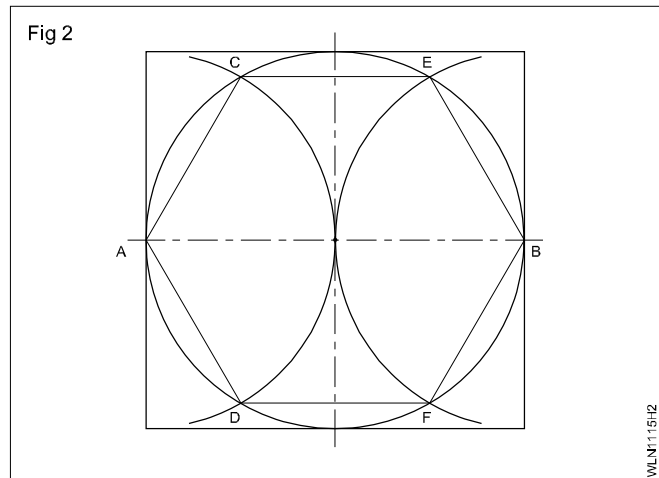
## Task 2

### Job Sequence

- Clean the surface of raw material 100 15F6 50 mm long.
- Mark the center line of the job, and punch the intervention.
- Scribe the circle of diameter 100 mm, using divider (Fig 1).



- Scribe the arc with center A of radius 50 mm (Fig 1) cutting the circle, repeat with center B to scribe the arc as shown in Fig 1.
- Scribe the lines to join AC, CE, EB, BF, DF and DA as in Fig 2, using straight edge and scribes to form hexagon.
- Punch witness marks to complete the hexagon shape.
- Mark the triangle with in the hexagon as per the dimension shown in the drawing, and punch witness marks to complete the triangle.
- Drill a hole of  $\varnothing 6\text{mm}$  on center mark.
- Set the oxy-acetylene plant and cutting blowpipe for gas welding the geometrical profiles.



- Attach suitable nozzle for gas cutting, according to thickness metal to be cut.
- Adjust the gas measure of acetylene and cutting oxygen, according to the thickness of metal to be cut.
- Adjust proper cutting flame, and hold the cutting blowpipe at  $90^\circ$  (Refer skill sequence on 1.1.15).
- Start the gas welding from drilled hole to triangle line marked.
- Cut the profile on marked line to complete the triangle.
- Start the cutting from the edge of plate to the marked line of hexagon as required.

**Maintain correct speed and distance of nozzle while cutting.**

- Close cutting oxygen and extinguish the flame on completion of cut.
- Clean the cut, after one job is cooled.
- Inspect the surface cut for uniformity.

## Task 3

- Clean the surface of metal to be cut.
- Mark and punch as per the profile shown in the drawing.
- Set the gas cutting plant with a cutting blow pipe.
- Attach the correct cutting nozzle according to thickness of the metal.
- Adjust the gas measure for the cutting.
- Adjust a proper cutting flame and has the blowpipe in proper position.
- Heat the metal surface at the starting point to bright red hot.
- Move the cutting blow pipe towards the other end following the punched line slowly and steadily.
- Maintain a correct speed and distance of the nozzle while cutting.
- Close the cutting oxygen and extinguish the flame on completion of the cut.
- Clean the cut, and inspect for its accuracy.

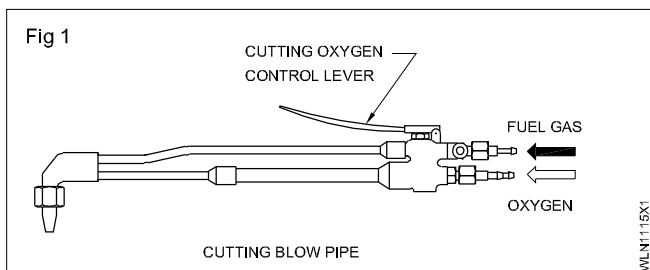
## Skill Sequence

### Setting the gas cutting plant:

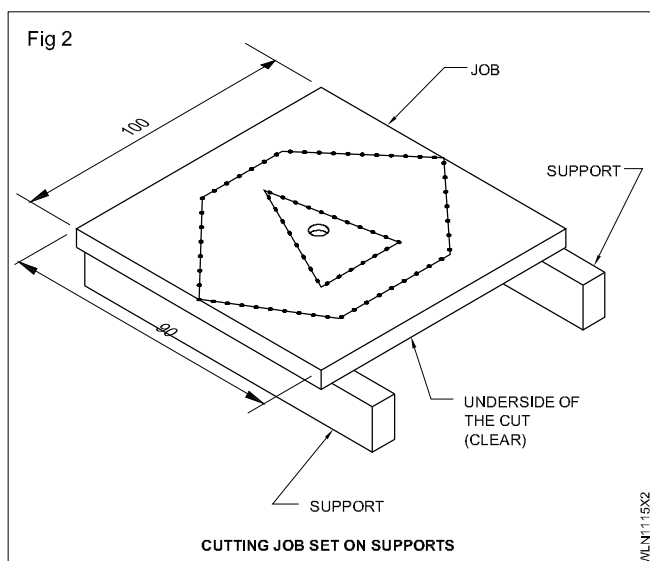
**Objectives:** This shall help you to

- set the work pieces for bevel cutting
- gas cut bevel surfaces by hand
- inspect the bevel cut.

Set the oxy-acetylene gas cutting plant in the same way as was done for welding and connect the cutting blow pipe in the place of the welding blowpipe. (Fig 1) Also change the oxygen welding regulator with oxygen cutting regulator.



**Setting the job for straight line cutting of Triangular shape (Fig 2):** Mark and punch straight lines on the plate.



Set the job on the cutting table so that the parting piece is free to fall.

**Ensure that the underside of the cutting line is clear and no combustible materials are lying nearby.**

**Adjusting cutting flame:** Select the cutting nozzle and set the gas pressure as per the cutting job thickness. (Table 1)

**TABLE 1**  
Data for cutting

Diameter of cutting oxygen orifice nozzle	Thickness of steel plate	Cutting oxygen Pressure
(1) mm	(2) mm	(3) kg/cm <sup>2</sup>
0.8	3-6	1.0-1.4
1.2	6-19	1.4-2.1
1.6	19-100	2.1-4.2
2.0	100-150	4.2-4.6
2.4	150-200	4.6-4.9
2.8	200-250	4.9-5.5
3.2	250-300	5.5-5.6

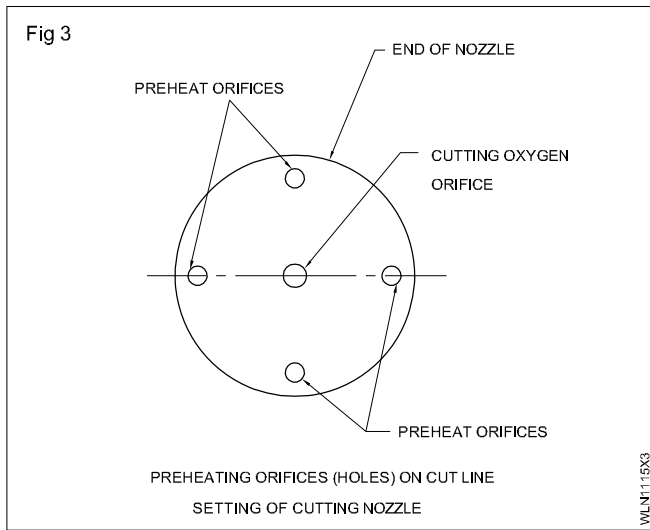
Acetylene pressure should be 0.15 kgf/cm<sup>2</sup> for all thickness of plates.

Select 0.8 mm  $\varnothing$  cutting oxygen (orifice) nozzle for cutting a 6 mm thick plate.

Set 1.4 kg/sq.cm pressure for the cutting oxygen and 0.13 kg/sq.cm pressure for the acetylene gas.

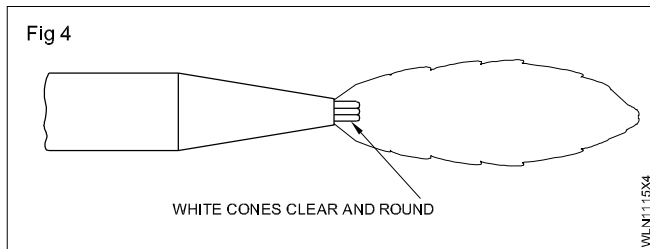
Ensure safety apparel is worn.

Fix the cutting nozzle into the cutting blowpipe correctly. (Fig 3)



Check for leakage in the blowpipe connections of oxygen and acetylene gas lines.

Adjust the neutral flame for preheating. (Fig 4)



Ensure that the flame adjustment is not disturbed while operating the cutting oxygen lever.

**Straight line cutting:** Keep the hand cutting blowpipe at 90° angle with the plate surface and start cutting a straight line. (Fig 5)

Preheat the starting point to red heat before pressing the cutting oxygen lever. (Fig 5)

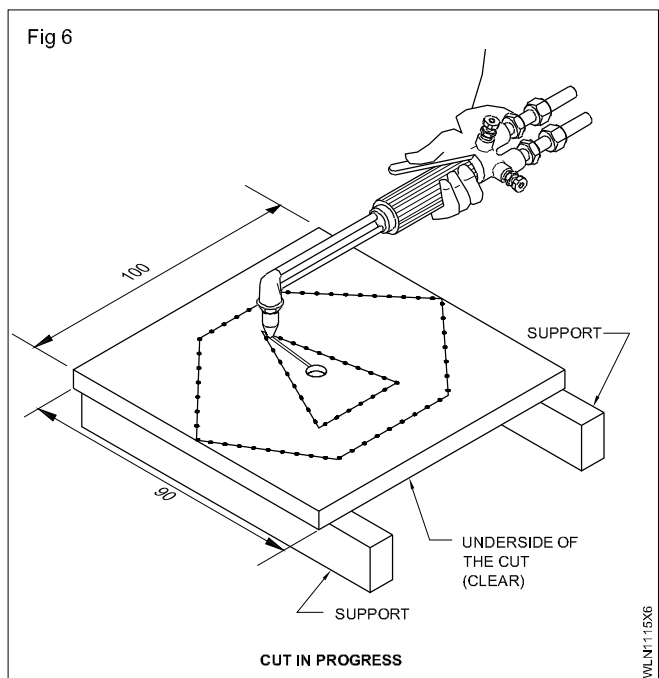
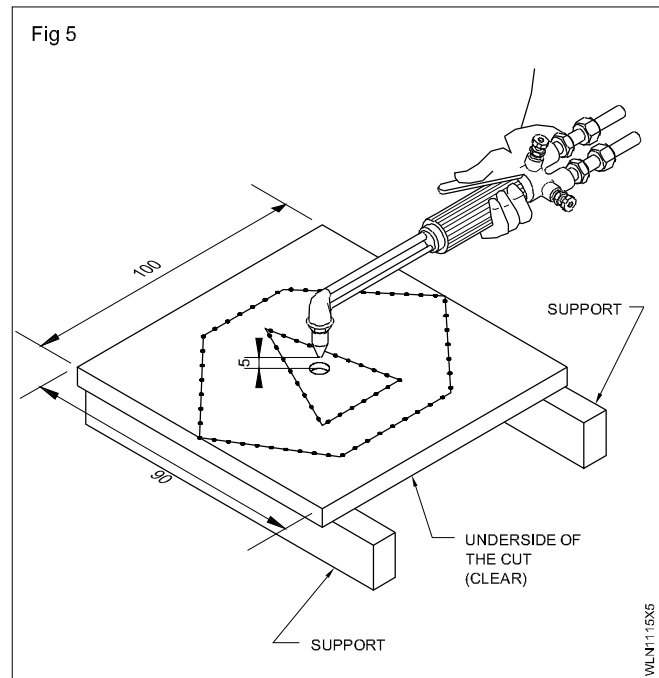
Keep the distance between the work piece and the nozzle about 5 mm to avoid backfire. (Fig 5)

Release the cutting oxygen by pressing the cutting oxygen control lever and start the cutting action and move the blowpipe along the punched line with uniform speed. (Fig 6)

Ensure straight travel without any side-to-side movement.

The nozzle angle is 90° with the plate surface till the completion of cut.

Open the cutting oxygen valve fully.

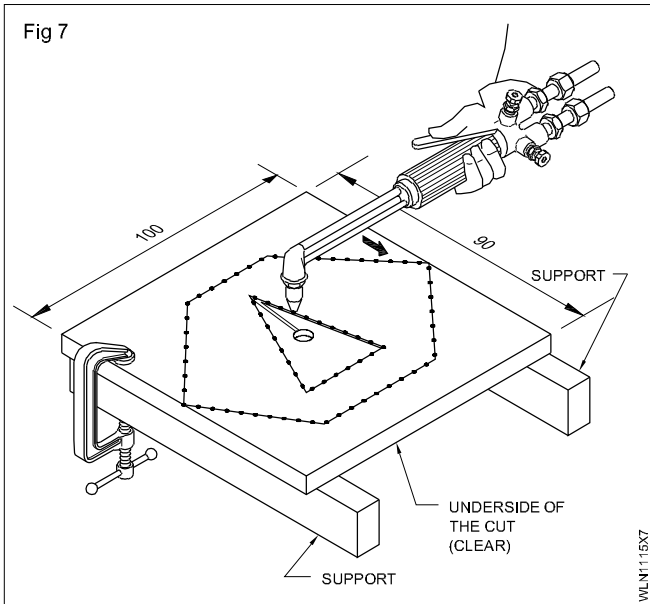


If possible fix a straight edge or template to the plate and fix a support to the cutting nozzle so as to ensure constant distance between the tip of the nozzle and the plate surface and maintain a uniform straight cut. (Fig 7)

- Complete to cut the shown in of interned for angle along the punched times.

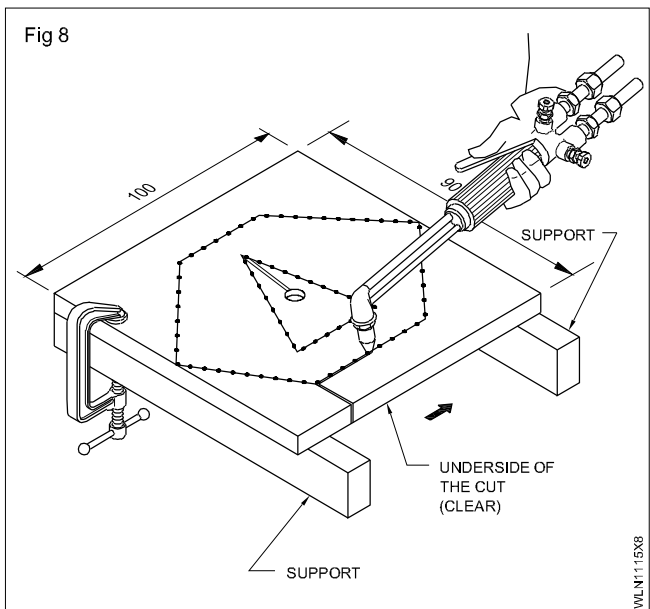
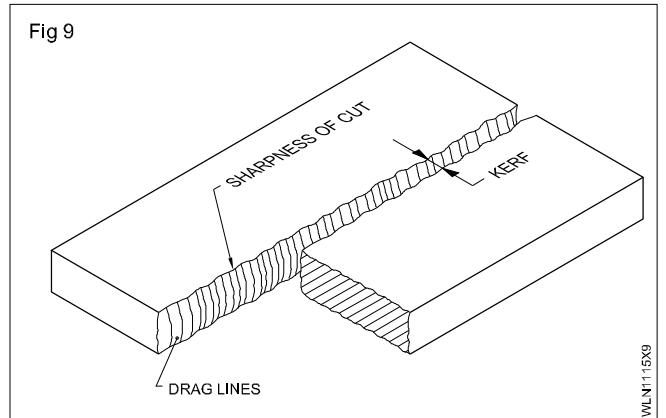
Hexagon cutting

- Set the job as shown in Fig 8.
- Hold the cutting flow pipe (nozzle) at required angle is 90°.
- Cut the hexagon along the punched lines.



Inspect the cutting for

- uniform and smooth cut or drag line
- straightness, sharpness
- width of the cut (Kerf) Fig 9

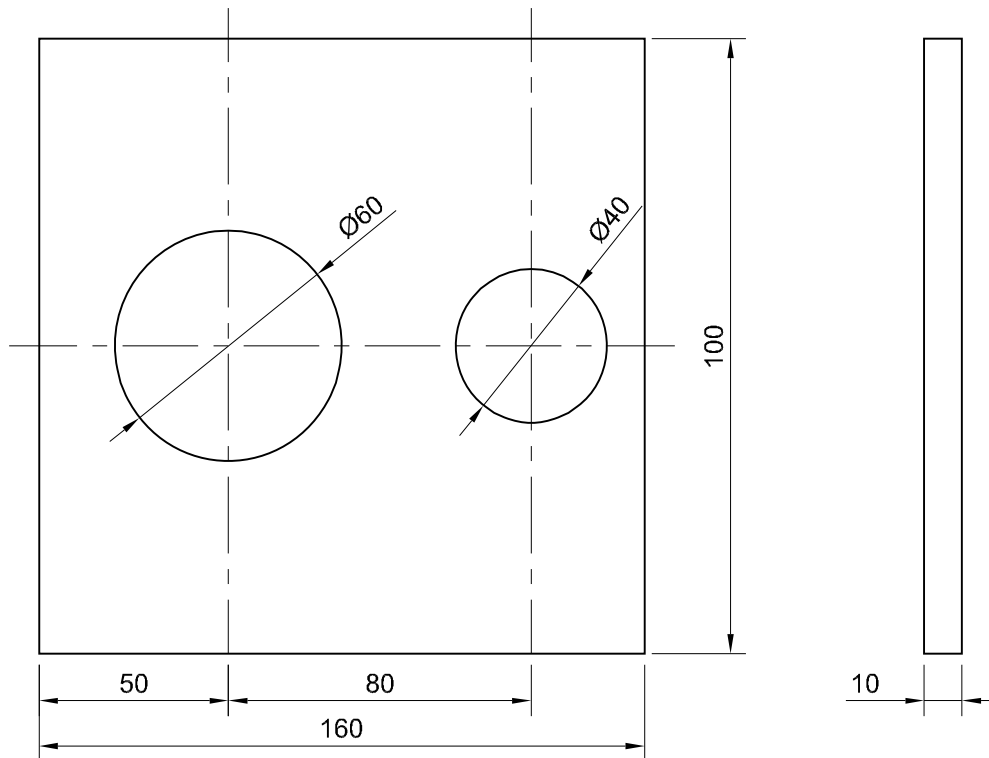


Scan the QR Code to view the video for this exercise

**Circular gas cutting on MS plate 10mm thick by profile cutting machine (OAGC-03)**

**Objectives:** At the end of this exercise you shall be able to

- set the profile cutting machine
- set the cutting parameter for cutting
- cut the circle as per dimensions.



1	100 ISF 10-160	-	Fe 310	TASK-2	-	1.1.16
NO.OFF	STOCK SIZE	SEMI-PRODUCT	MATERIAL	PROJECT NO.	PART NO.	EX. NO.
SCALE NTS	<b>CIRCULAR GAS CUTTING ON MS PLATE 10mm THICK BY PROFILE CUTTING MACHINE (OAGC-03)</b>				DEVIATIONS	TIME 7Hrs
					CODE NO. WLN1116E1	



## Job Sequence

- Set the cutting machine and connect the oxygen and acetylene cylinders, regulators to the hoses of the machine and fix a suitable cutting nozzle.
- Fit the circular and profile template on the cutting machine table.
- Clean the surface of the metal plate to be cut.
- Select and fix the nozzle as per the thickness of the plate to be cut.
- Clean the track on which the cutting torch assembly unit is mounted and the circular and profile templates and make sure that there is no dirt on them.
- Check the starting lever and ensure that it is in neutral position.
- Set the required pressure of oxygen and acetylene according to the size of the nozzle.
- Set the required speed in the speed control dial according to the thickness of the metal to be cut.
- Adjust the nozzle to a height such that the inner cone of the preheating flame is 3 mm from the surface of the metal to be cut.
- Place the cutting machine at the starting point.
- Ignite and set the neutral flame.
- Allow for sufficient preheating, and then switch 'on' the jet of oxygen.
- Simultaneously switch 'on' the machine to move the cutting unit forward with the correct speed on the rails to make a straight line cut.
- Stop the machine and turn the switch to neutral position at the end of the cut.
- Set the cutting nozzle to 30° angle and cut the bevel similar to the straight line cut.
- Turn the job plate by 180° and cut the 60° bevel angle by setting the cutting nozzle to 60°.
- Arrest the linear movement of the cutting unit of the machine with the rails using a clamp and attach it to the pivot block used for cutting circle and profiles.
- Set the pivot block to get the required diameter and fix it on the machine table.
- Set the cutting nozzle perpendicular to the job plate and ignite it and set the preheating flame.
- When the plate becomes red hot, open the stream of cutting oxygen and cut the circle.
- For profile cutting attach the template of the profile to the machine table and make the cutting head unit to follow the profile.
- After the cut is over stop all machine movements and remove the slag from all the gas cut surfaces.
- Use tongs while handling the gas cut job.
- Ensure that the molten slag diving cutting and solidified hot slag chipped after cutting fall into a collecting through kept below the table.
- Clean the cutting edges from slag and inspect the cut for gas cutting defects.

## Skill Sequence

### Assembly of the portable cutting machine

**Objectives:** This shall help you to

- **assemble the cutting machine**
- **set the templates system for reproduction**
- **set the correct gas pressure.**

The assembly of the machine, the use of templates or systems of reproduction, the position of the work, the speed range and cutting nozzles vary according to the type of the machines.

Assemble the accessories like cutting head for straight and bevel cutting with the cutting machine. (Fig 1)

Select the 1.2mm size of the cutting nozzle for 10mm thick plate.

Set the correct gas pressure of 0.15 kg/cm<sup>2</sup> for acetylene and 1.4 to 2 kg/cm<sup>2</sup> for oxygen for 1.2mm size nozzle.

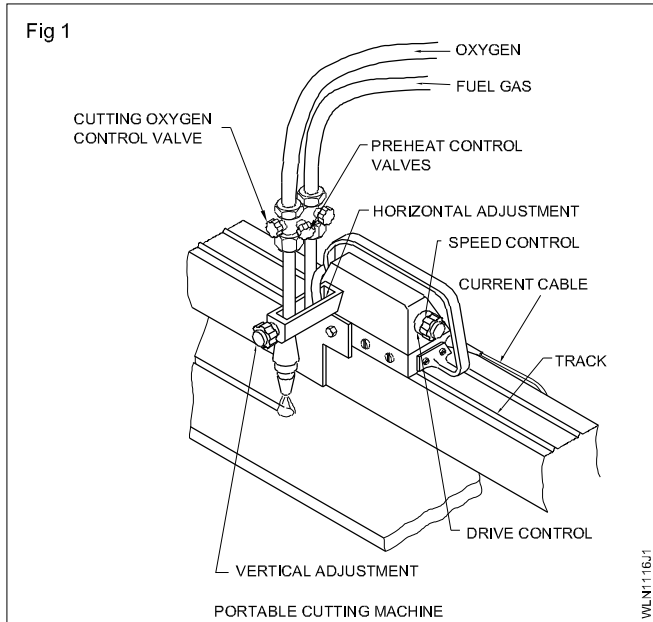
Set the machine to run freely as per the regulated speed i.e. 50cm/min for 10mm thick plate.

Ignite the flame and adjust the neutral flame.

Set the nozzle tip to a correct distance from the surface of the plate to be cut i.e. about 7 to 8mm.

Start the machine and run to the required distance to cut the metal.

Switch 'off' the machine and extinguish the flame at the end of the cut.

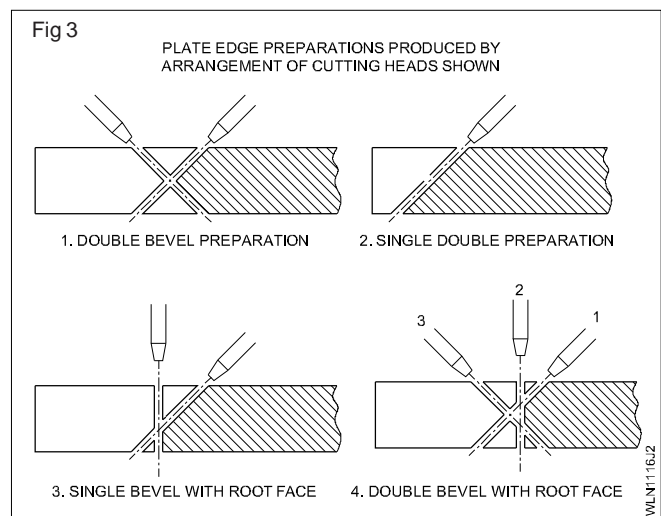
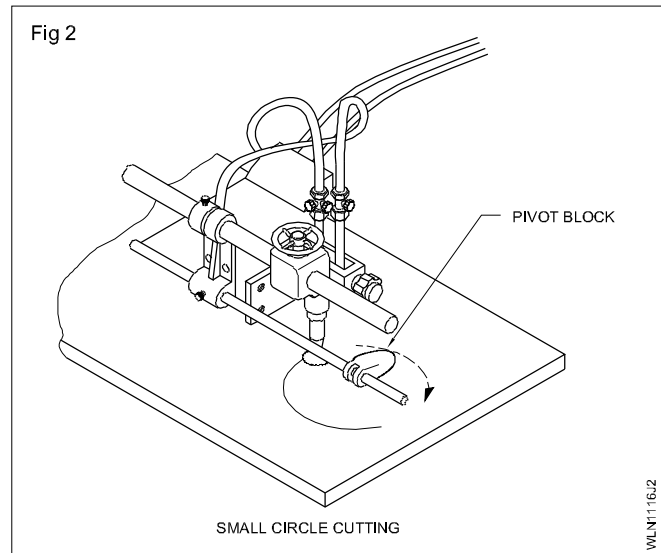


Remove the plate, clean the iron oxide slag and inspect the cut surface.

For cutting a bevel edge tilt the cutting torch nozzle to the required angle and follow the same skill sequence followed for straight line cutting. Fig 2.

For cutting a circle, attach cutting torch nozzle to the pivot block (Fig 3) and follow the same method used to cut straight line and bevel. It is important to pierce a small hole inside the circumference of the circle to be cut and then move the torch to the nearest point on the circumference. Then use the pivot block to move the flame along the circumference of the circle.

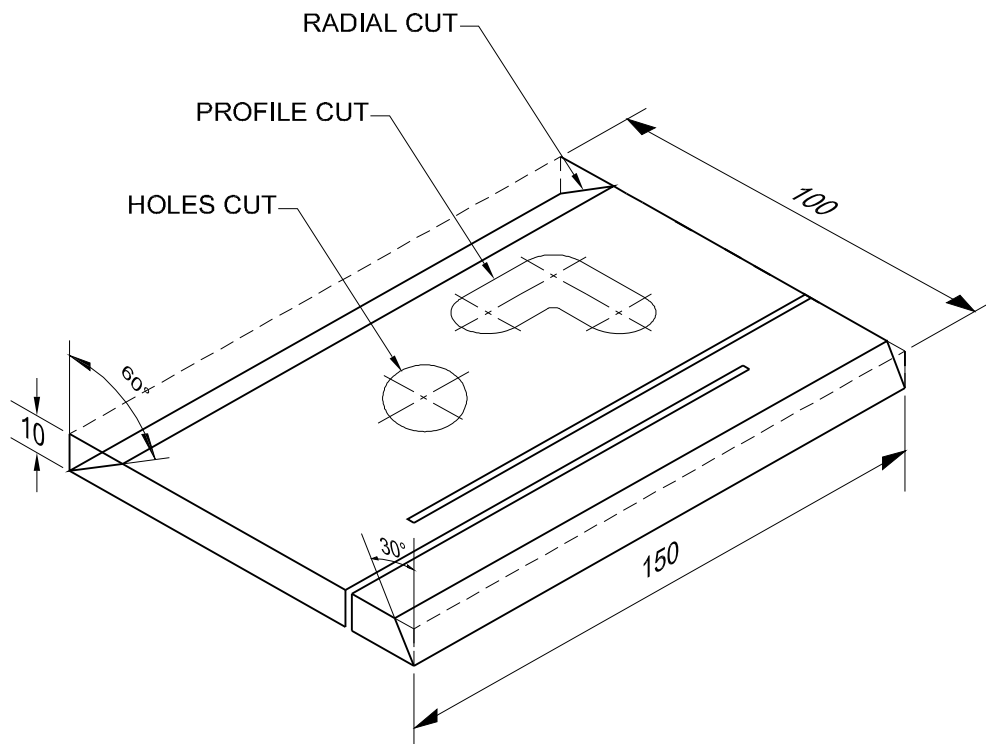
To cut a profile the same sequence used for circle cutting is followed except that a template similar to the profile to be cut is mounted on the table and a tracer attached to the cutting head will follow the template profile. The torch flame will cut the profile on the job.



**Marking and perform radial cuts, cutting out holes using oxy-acetylene gas cutting**

**Objectives:** At the end of this exercise you shall be able to

- assemble a gas cutting machine
- select the cutting nozzle No. and the cutting oxygen pressure
- set the work and speed range for cutting
- operate the machine and make a radial profile cutting
- clean the cut surfaces and inspect for quality.



1	100 ISF 10 - 150		Fe310 - W			1.1.17
NO.OFF	STOCK SIZE	SEMI-PRODUCT	MATERIAL	PROJECT NO.	PART NO.	EX. NO.
SCALE NTS	<b>MARKING AND PERFORM RADIAL CUTS ,CUTTING OUT HOLES USING OXY-ACETYLENE GAS CUTTING</b>				LINEAR TOLERANCE ±1	TIME 15 Hrs
					CODE NO. WLN1117E1	

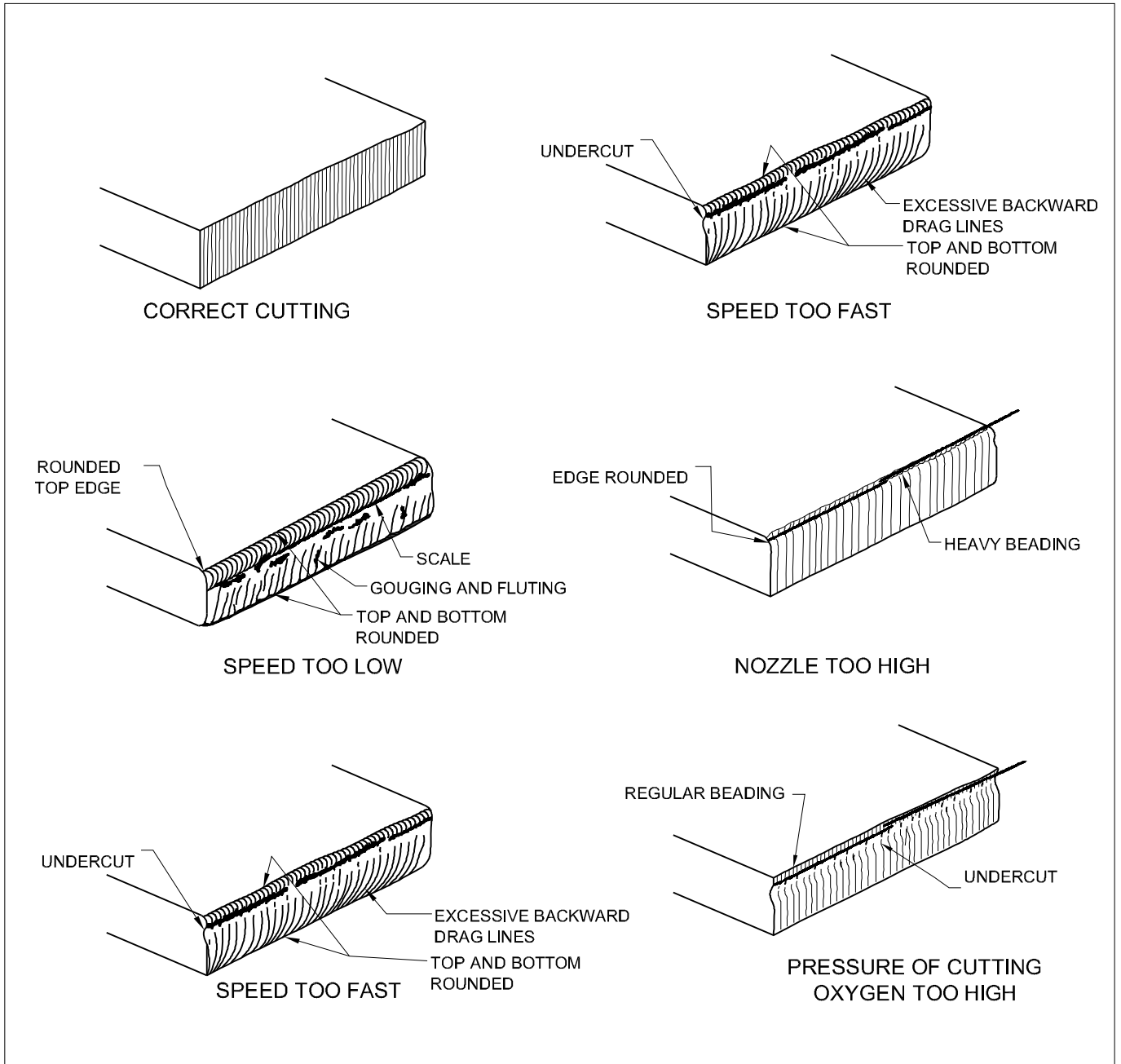
## Job Sequence

- Set the cutting machine and connect the oxygen and acetylene cylinders, regulators to the hoses of the machine and fix a suitable cutting nozzle.
- Fit the profile template on the cutting machine table.
- Clean the surface of the metal plate to be cut.
- Select and fix the nozzle as per the thickness of the plate to be cut.
- Clean the track on which the cutting torch assembly unit is mounted and the profile templates and make sure that there is no dirt on them.
- Check the starting lever and ensure that it is in neutral position.
- Set the required pressure of oxygen and acetylene according to the size of the nozzle.
- Set the required speed in the speed control dial according to the thickness of the metal to be cut.
- Adjust the nozzle to a height such that the inner cone of the preheating flame is 3 mm from the surface of the metal to be cut.
- Place the cutting machine at the starting point.
- Ignite and set the neutral flame.
- Allow for sufficient preheating, and then switch 'on' the jet of oxygen.
- Simultaneously switch 'on' the machine and make the cutting head unit to follow the profile.
- After the cut is over stop all machine movements and remove the slag from all the gas cut surfaces.
- Use tongs while handling the gas cut job.
- Ensure that the molten slag diving cutting and solidified hot slag chipped after cutting fall into a collecting through kept below the table.
- Clean the cutting edges from slag and inspect the cut for gas cutting defects.

**Identification of cutting defects viz, distortion, grooved, fluted or ragged cuts, poor draglines, rounded edges, tightly adhering slag (OAGC-06)**

**Objectives:** At the end of this exercise you shall be able to

- identify the cutting defects in gas welding
- record the cause and effects of gas cutting defects.



1	100 ISF 10 - 150		Fe310 - W			1.1.18
NO.OFF	STOCK SIZE	SEMI-PRODUCT	MATERIAL	PROJECT NO.	PART NO.	EX. NO.
SCALE NTS	<b>IDENTIFICATION OF GAS CUTTING DEFECTS VIZ,DISTORTION,GROOVED,FLUTED OR RAGGED CUTS,POOR DRAGLINES,ROUNDED EDGES,TIGHTLY ADHERING SLAG (OAGC-06)</b>				DEVIATIONS ± 4	TIME 02 Hrs
					CODE NO. WLN1118E1	

## Job Sequence

- Observe the defects shown in drawing.
- Record the defects name and cause and effects for the defects in table 1.
- Get it checked by the instructor, training officer.

**TABLE 1**

<b>S. No.</b>	<b>Appearance of cut</b>	<b>Remedies</b>
1		
2		
3		
4		
5		
6		

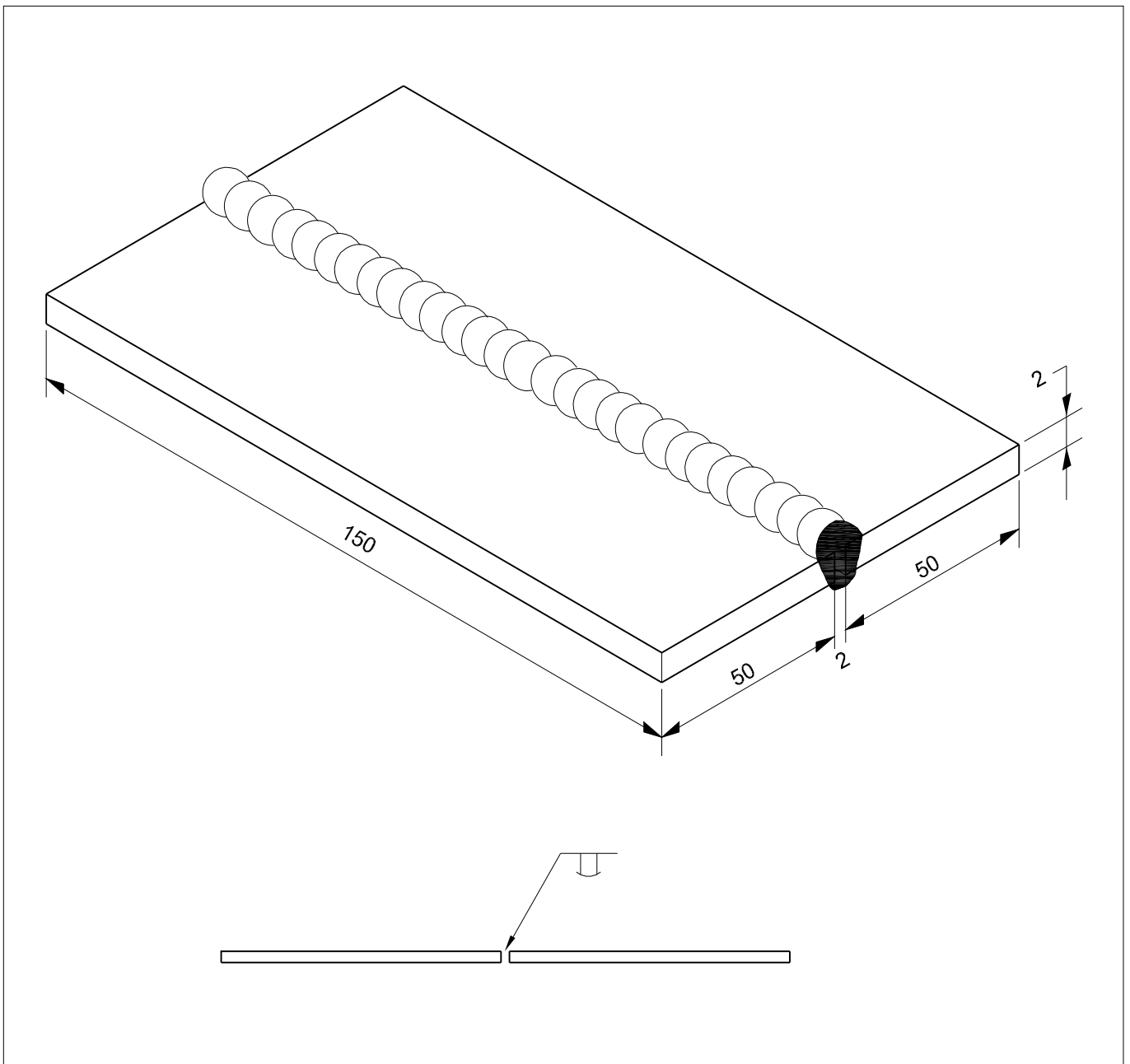


Scan the QR Code to view the video for this exercise

**Square butt joint on MS sheet 2 mm thick in flat position (1G) (OAW-04)**

**Objectives:** At the end of this exercise you shall be able to

- prepare the job to the given size as per drawing
- file the edges of the plate to square without burr
- set the job as a square butt joint with proper root gap and tack weld them
- weld the square butt joint in flat position using leftward technique in one run
- clean and inspect the butt weld for root penetration and surface uniformity.



2	ISST 100 x 2 - 150		Fe 310 - W			1.2.19
NO.OFF	STOCK SIZE	SEMI-PRODUCT	MATERIAL	PROJECT NO.	PART NO.	EX. NO.
SCALE NTS	<b>SQUARE BUTT JOINT ON M.S SHEET 2mm THICK IN FLAT POSITION (1G) (OAW-04)</b>				TOLERANCE ±1	TIME 8 Hrs
					CODE NO. WLN1219E1	

## Job Sequence

- Prepare the job pieces as per drawing.
- File the edges to square and ensure thorough cleaning of the joining edges.
- Set the job pieces on the welding table to form a square butt joint with a root gap of 2 mm.
- Set the gas welding plant, fix nozzle No. 7 and set the gas pressure of 0.15 kg/cm<sup>2</sup> for both gases.
- Select C.C.M.S. filler rod 3 mm  $\varnothing$  for tacking and welding.

**Wear safety apparels and gas welding goggles.**

- Set neutral flame.
- Tack the pieces at both ends and at center, using 1.6 mm  $\varnothing$  filler rod with 2mm root gap at right end and 3mm root gap at the left end.

**Tacks should be well fused and penetrated and done on the bottom side of the joint.**

- Check the alignment and root gap and reset if necessary.
- Clean the tacks and set the job on the welding table in a flat position, over fire brick supports.

**Turn the tack weld side down.**

## Skill Sequence

### Square butt joint

**Objective:** This shall help you to

- **prepare and gas weld the square butt joint.**

**Preparation:** Prepare the job pieces of size 150x50x2.0 mm by shearing and then by filing.

**Setting and tacking:** Set the prepared job pieces on the welding table with a root gap of 2mm at the right end and 3mm at the left end and in alignment. (Fig 1)

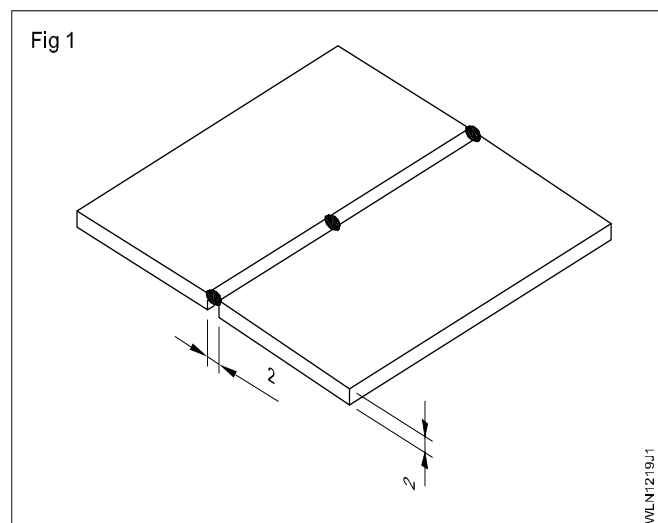
The root gap is increasing from right end to the left end because the gap will get closed as the weld proceeds towards the left end, due to expansion of the base metal.

Tack-weld the joint at equal intervals to hold them together, maintaining the alignment. (Fig 1)

Ensure that the

- distance between the tack-welds is 75 mm.
- length of the tack-weld is 6 mm.

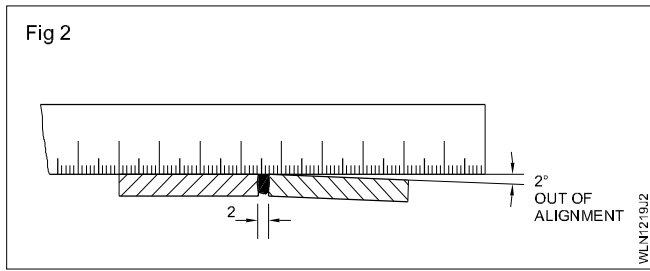
- Start the weld at the right end of the job.
- Direct the flame at the beginning of the seam (welding line) with the blowpipe nozzle at an angle of 60° - 70° towards right.
- Hold the filler rod at an angle of 30° - 40° with the seam towards left.
- Fuse the edges uniformly and add filler metal by up and down (piston like) motion and proceed to weld towards left.
- Maintain a uniform speed of the blowpipe with slight circular motion.
- Stop at the left end, fill the crater and complete the weld.
- Extinguish the flame, cool the nozzle in water and keep it on the cylinder trolley.
- Clean the welded joint and remove distortion.
- Inspect the joint by visual inspection for:
  - slight convexity with uniform width and height of bead without undercut.
  - uniform ripples without porosity.
  - uniform root penetration.
- Repeat the exercise till you get good results.



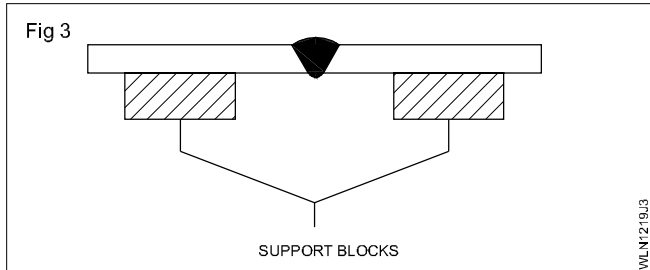
Tack welds should be on the back side of the joint to be welded and in line with the joint.



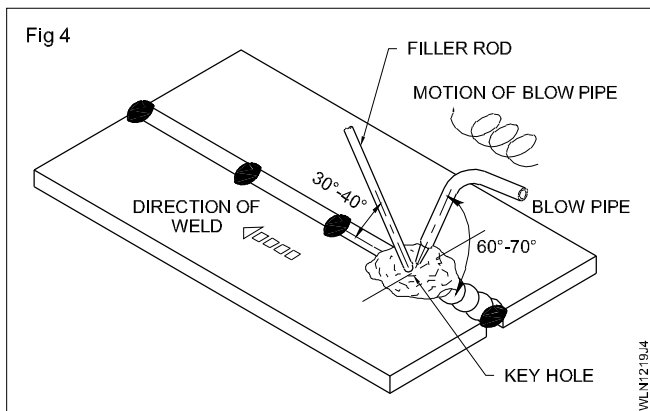
Check the alignment after tacking, and reset, if the sheets are out of alignment. (Fig 2)



**Welding:** Keep free space under the joint for complete penetration. (Fig 3)



Start the weld at the right end of the joint. (Fig 4)



Weld a well fused uniform bead with complete penetration using leftward technique. (Fig 4)

Manipulate the blowpipe to maintain necessary motion to the blow pipe and the filler rod and the recommended angle of blowpipe and the filler rod.

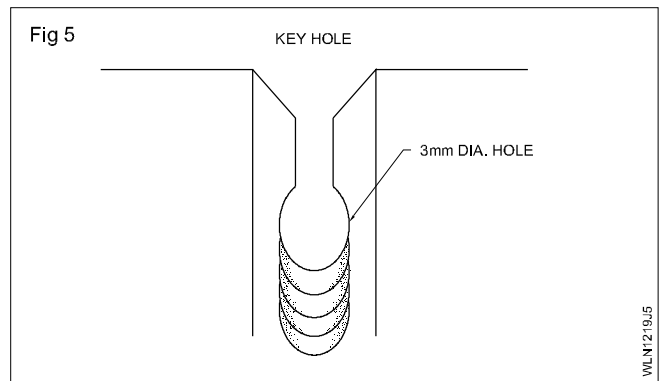
Maintain uniform travel speed and feed to the flame and the filler rod.

Maintain a keyhole which is a clear indication that the melting is taking place up to the bottom of the root of the joint ensuring better root penetration. (Fig 5)

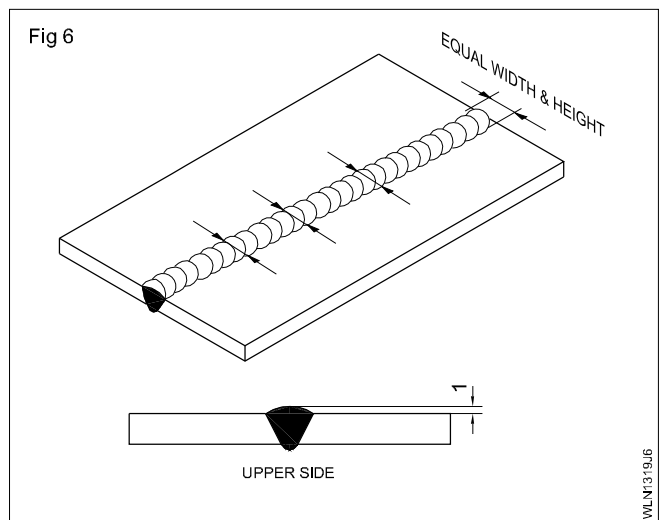
Clean the deposited bead using wire brush.

Inspect the quality of weld by:

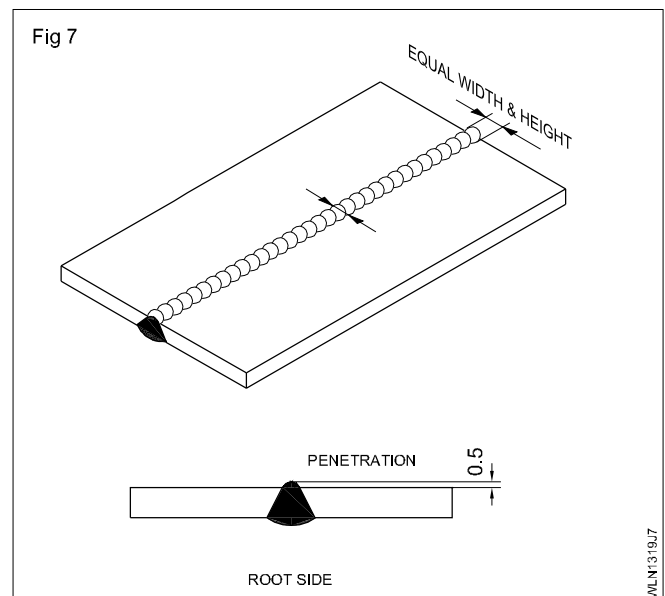
- checking the finish of the job



- checking the alignment (remove distortion if required)
- checking the uniformity of width and height of the weld bead in size (Fig 6)



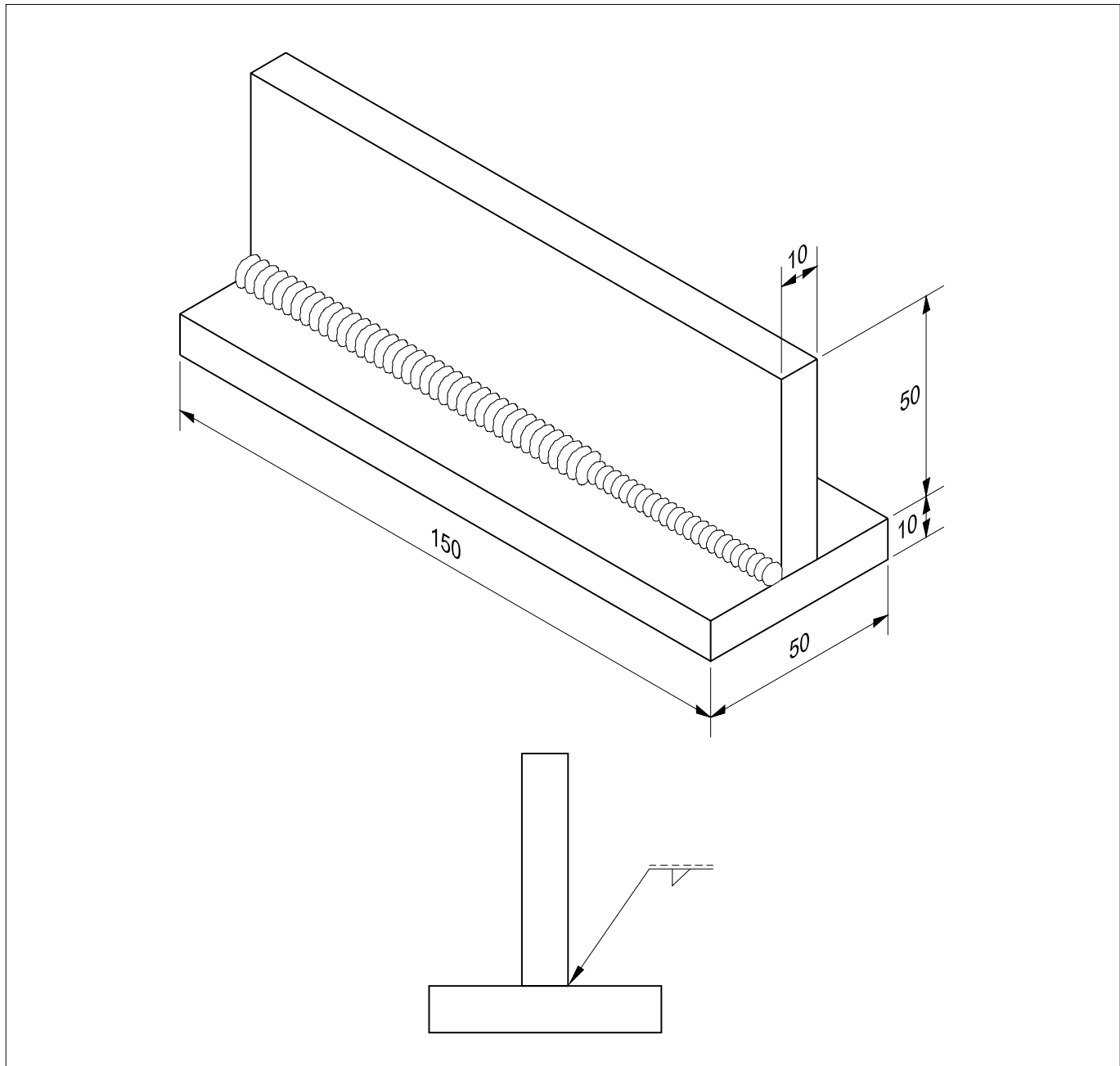
- checking the uniformity of the ripples, fusion and complete penetration (Fig 7)
- checking that the weld is free from faults such as porosity, undercut, lack of fusion, unfilled crater etc.



**Fillet "T" joint on MS plate 10mm thick in flat position (1F)-(SMAW-04)**

**Objectives:** At the end of this exercise you shall be able to

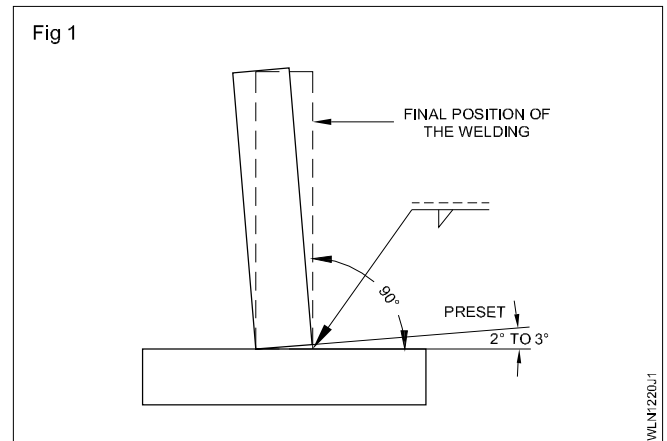
- set and tack plate pieces in alignment as tee joint and by keeping distortion allowance
- set the 'T' joint in flat position for welding
- deposit root run in 'T' joint of proper size and penetration
- deposit final covering run in the 'T' joint of proper leg size
- clean the weldment and inspect surface defects on the fillet weld.



2	50 ISF 10 - 150	-	Fe 310 - W	-	-	1.2.20
NO.OFF	STOCK SIZE	SEMI-PRODUCT	MATERIAL	PROJECT NO.	PART NO.	EX. NO.
SCALE NTS	<b>FILLET "T" JOINT ON M.S PLATE 10mm THICK IN FLAT POSITION.(1F) - (SMAW-04)</b>				TOLERANCE ±1	TIME 8Hrs
					CODE NO. WLN1220E1	

## Job Sequence

- Cut the plate by gas cutting/hacksaw cutting as per drawing.
- Grind the edges square.
- Use goggles while grinding.
- Clean the joining edges and surface of the plates.
- Wear protective clothing.
- Set the pieces in the form of Tee as per drawing and Tack-weld on both ends.
- Preset the pieces to have  $92^\circ$  to  $93^\circ$  angle between the plate surfaces. (Fig 1) i.e. give a distortion allowance of  $2^\circ$  to  $3^\circ$ .
- Set the Tee joint in a flat position.
- Connect the electrode cable to the negative terminal, if a DC machine is used.
- Deposit root run using a 3.15mm dia. medium coated M.S. electrode and 110 amps welding current.
- Ensure uniform root penetration and an electrode angle of  $45^\circ$  between the plates and  $80^\circ$  with the weld line.
- Wear chipping goggles.



- Remove the slag from the root run with a chipping hammer and clean with a wire brush.
- Deposit covering run with a weave motion using a 4mm dia. medium coated M.S. electrode and 160 amps welding current.
- Remove the slag from the final bead and clean the weld.
- Use weld gauge for checking the leg size of the weld. If you do not get the required 10mm leg length in 2 runs of weld deposit then deposit a third run using the same technique adopted for the second run.
- Inspect the Tee fillet weld for defects.

## Skill Sequence

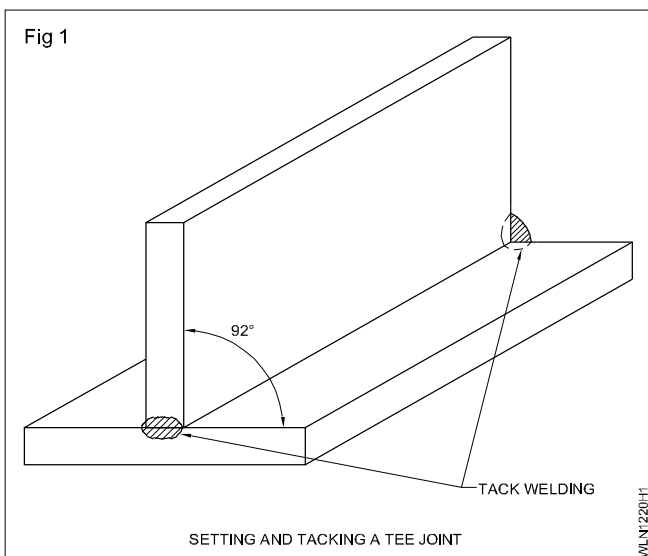
### Fillet 'T' joint in flat position (1F)

**Objective:** This shall help you to

- **prepare and make 'T' joint in flat position.**

#### Setting and tacking of a Tee joint (Fig 1)

Set the pieces in alignment forming  $92^\circ$  between the plates Fig 1. This presetting to  $92^\circ$  is done to compensate the effect of shrinkage forces when weld deposit cools down.



Tack-weld the pieces at both ends of the Tee joint by using a 3.15mm dia. medium coated M.S. electrode and 110/120 amps welding current.

Ensure the tacks are well fused at the root.

Check the alignment of the Tee joint after tacking.

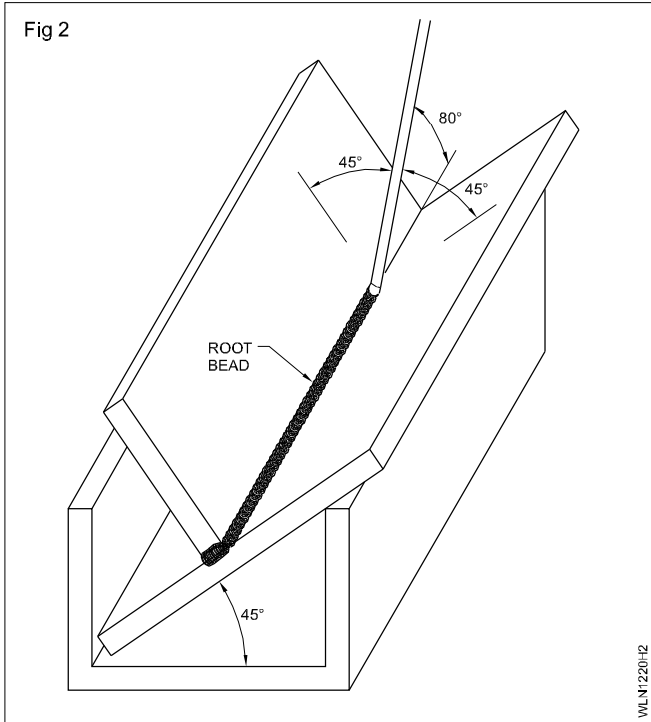
#### Welding a tee fillet joint

Use a channel to place the joint in a flat position. (Fig 2)

The electrode angle of  $45^\circ$  will help to fuse both plates equally and the  $80^\circ$  angle will help to get a good root penetration.

Proceed along the welding line with uniform travel speed and short arc to get uniform fusion and root penetration.

The slag has to be removed thoroughly from the root run so that the slag inclusion defect can be avoided in the next run.

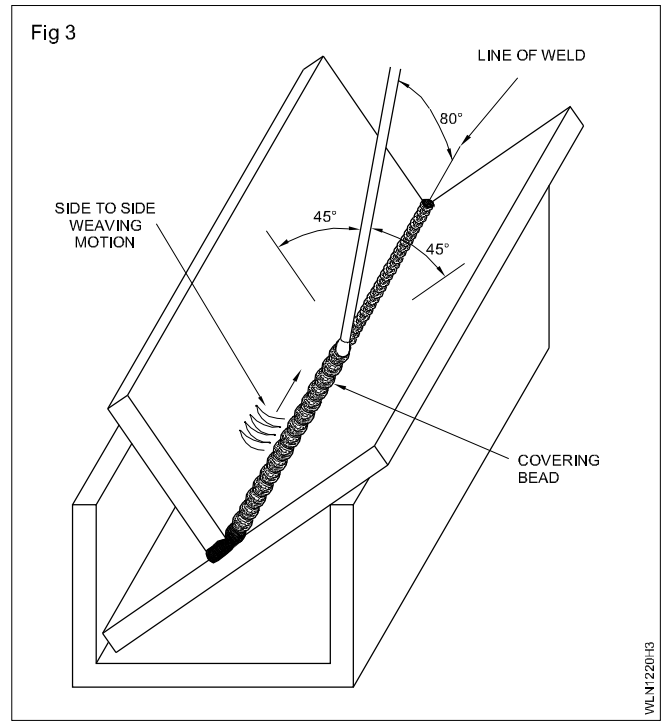


Use a slightly side-to-side weaving motion. (Fig 3) The width of weave should give a leg size of 10mm.

Maintain the same electrode angle as in the root bead.

If the leg size is less than 10mm then deposit a third run using the same technique used for the second run.

Clean the final covering bead thoroughly.



Stop the electrode weaving for a moment at the toes of the weld to avoid undercut. Fill the crater at the end of the bead.

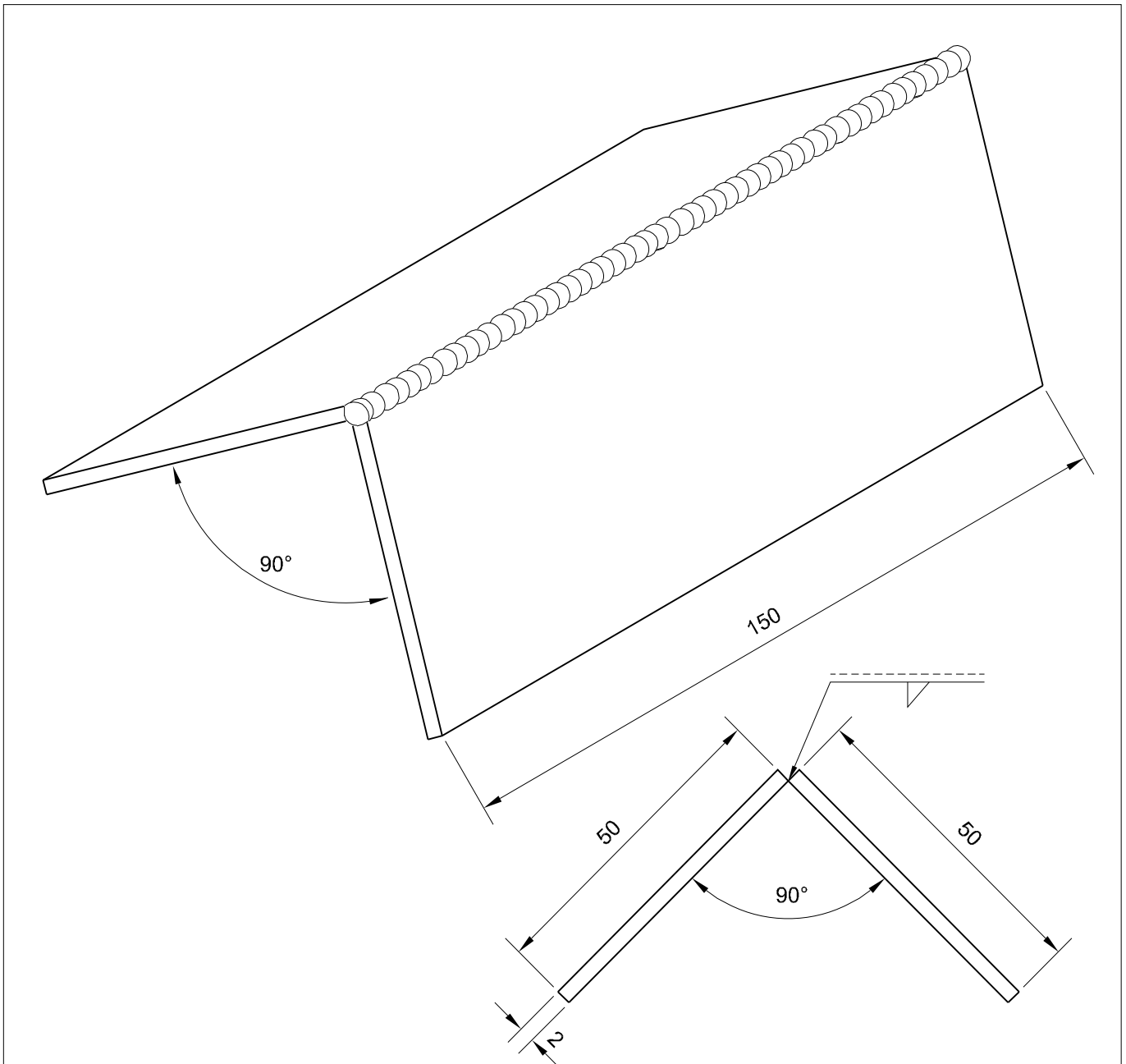
### Inspection of fillet weld

Inspect the fillet welds for defects, correct shape and size of fillet and equal leg length on either side of the weld.

**Open corner joint on M.S. sheet 2 mm thick in flat position (1F)-(OAW-05)**

**Objectives:** At the end of this exercise you shall be able to

- set and tack weld the job to form an open corner joint with the recommended root gap
- select a proper filler rod, nozzle size, and gas pressure
- weld the open corner joint by leftward technique
- manipulate the blow pipe and filler rod to get proper fusion of edges and root penetration
- clean and inspect (open corner joint) weldment for weld defects.



2	ISST 50 x 2 - 150	-	Fe 310 - W	-	-	1.2.21
NO.OFF	STOCK SIZE	SEMI-PRODUCT	MATERIAL	PROJECT NO.	PART NO.	EX. NO.
SCALE NTS		<b>OPEN CORNER JOINT ON M.S. SHEET 2mm THICK IN FLAT POSITION (1F) - (OAW-05)</b>			TOLERANCE ±0.5	TIME 9 Hrs
					code no. WLN1221E1	

## Job Sequence

- Prepare the edges of the sheets to be joined by filing.
- Set the sheets as outside corner joint by keeping at 90° angle between the members with a uniform root gap of 1.5mm between the edges.
- Fix nozzle No. 5 and adjust the gas pressure to 0.15kg/sq.cm. for both gases.
- Select C.C.M.S. filler rod 1.6 mm dia.
- Wear all safety clothing and use the gas welding goggle.
- Set natural flame, tack at both ends of the joint and at the center by fusing the edges adding filler rod.
- Check the correct alignment of the joint pieces with a try square, clean the tacks, and reset if needed.

### Use tongs for holding hot pieces.

- Keep the tacked joint on the welding table in a flat position.
- Hold the blowpipe and filler rod at an angle of 60° to 70° and 30° to 40° respectively with the weld line, start welding from the right hand edge of the joint, move towards the left hand side using the leftward technique.
- Keep the flame at the root of the joint, fuse both the edges uniformly, then dip the filler rod in the molten

pool, like a 'piston like' motion, steadily move and give slight circular motion to the blowpipe.

**Maintain 1 to 1.5 mm distance between the flame cone and the molten pool to avoid backfire, and to obtain good fusion of the root, use the key-hole technique.**

**Add filler metal at the top edge of the molten pool as required to build up the weld.**

**Synchronize the rate of travel and addition of filler metal to obtain a slightly convex bead with proper root penetration.**

- Stop welding at the left hand edge of the joint, after filling up the crater.
- Extinguish the flame, cool the nozzle and keep the blowpipe at a safe place.
- Clean the welded joint and inspect for:
  - uniform ripples with slightly convex bead with correct throat thickness.
  - uniform width and height of bead
  - uniform penetration of bead on the reverse side of the joint near the root (indication of root fusion).

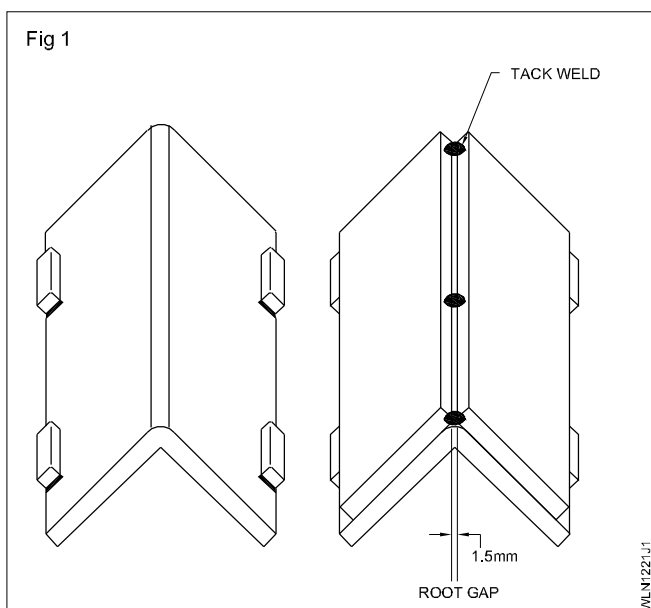
## Skill Sequence

### Open corner joint in flat position

**Objective:** This shall help you to

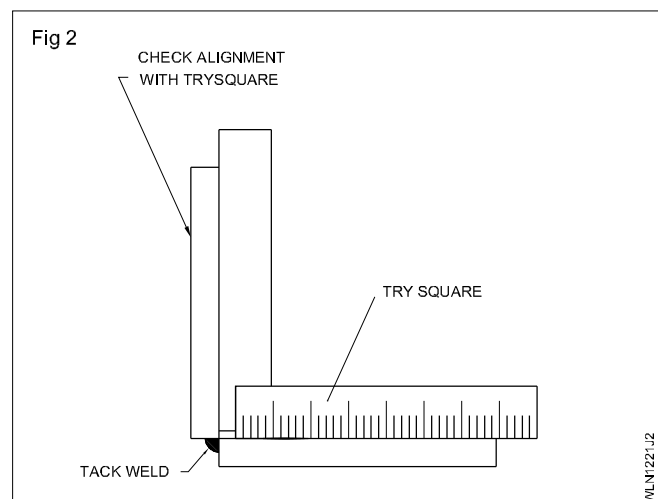
- **prepare and weld open corner joint in flat position.**

Set the job pieces prepared with square edges in correct position using angle iron support. (Fig 1)



Tack-weld the pieces at correct intervals in correct sequence, with 1.5 mm root gap.

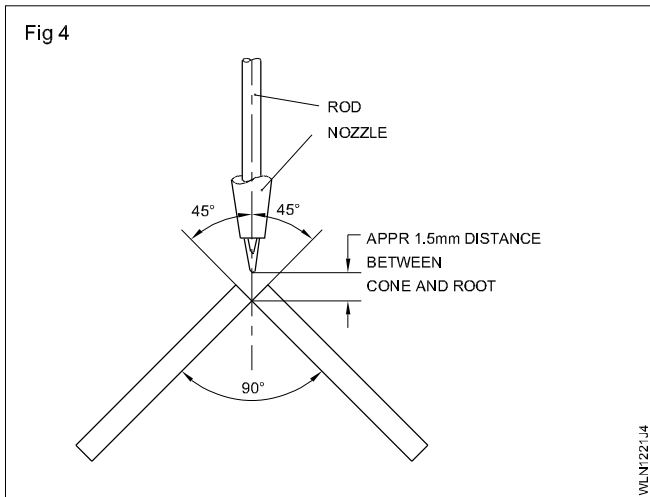
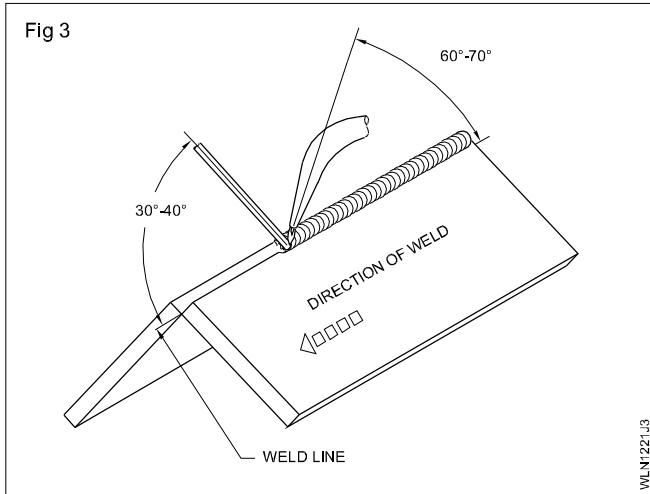
Check the alignment of the tacked pieces and reset, if required. Use a try square. (Fig 2)



## Fusion welding on open corner joint

Make uniform bead with correct penetration by:

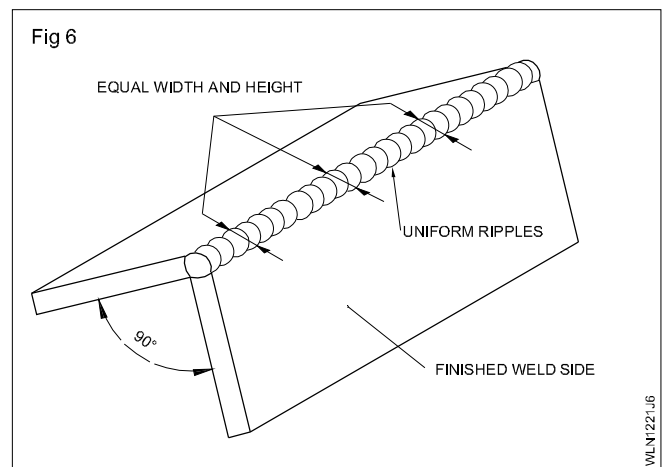
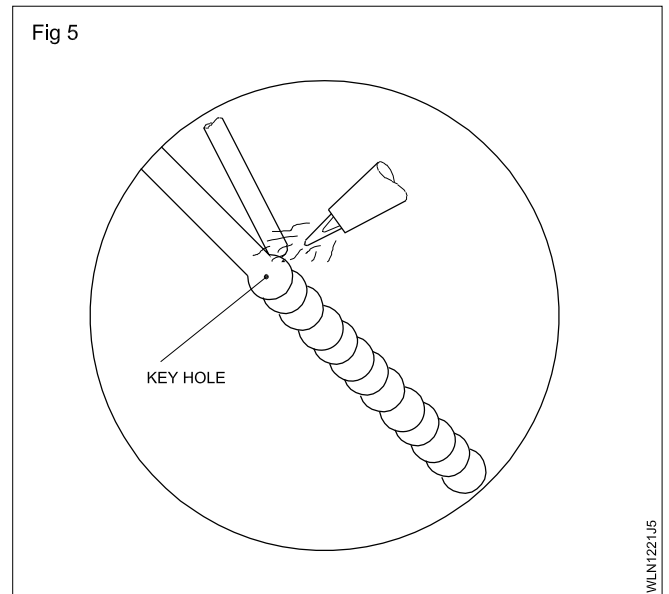
- holding the blowpipe and filler rod in correct position (Figs 3 and 4)



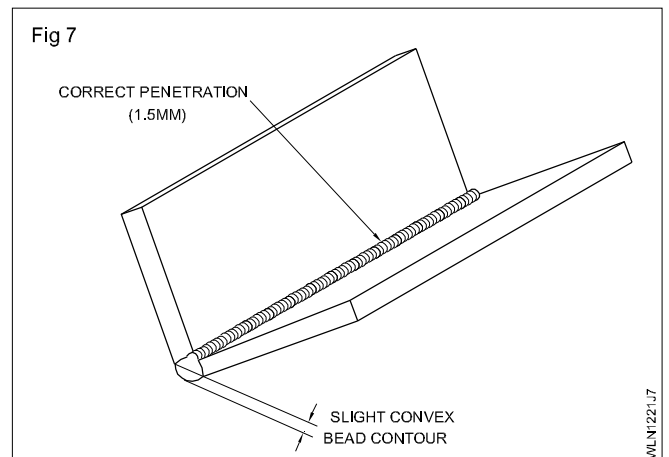
- maintaining uniform travelling speed
- fusing the edges with the keyhole formation to get full penetration. (Fig 5)
- ensuring the top edges of the sheets do not melt excessively.

Inspect the open corner welded joint for:

- correct alignment and uniformity of bead with correct penetration after cleaning the welded joint thoroughly
- uniform ripples with equal width and height of bead (Fig6)

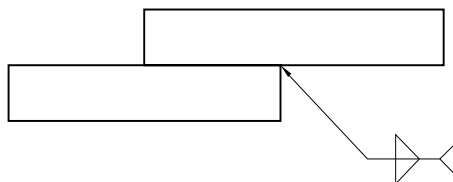
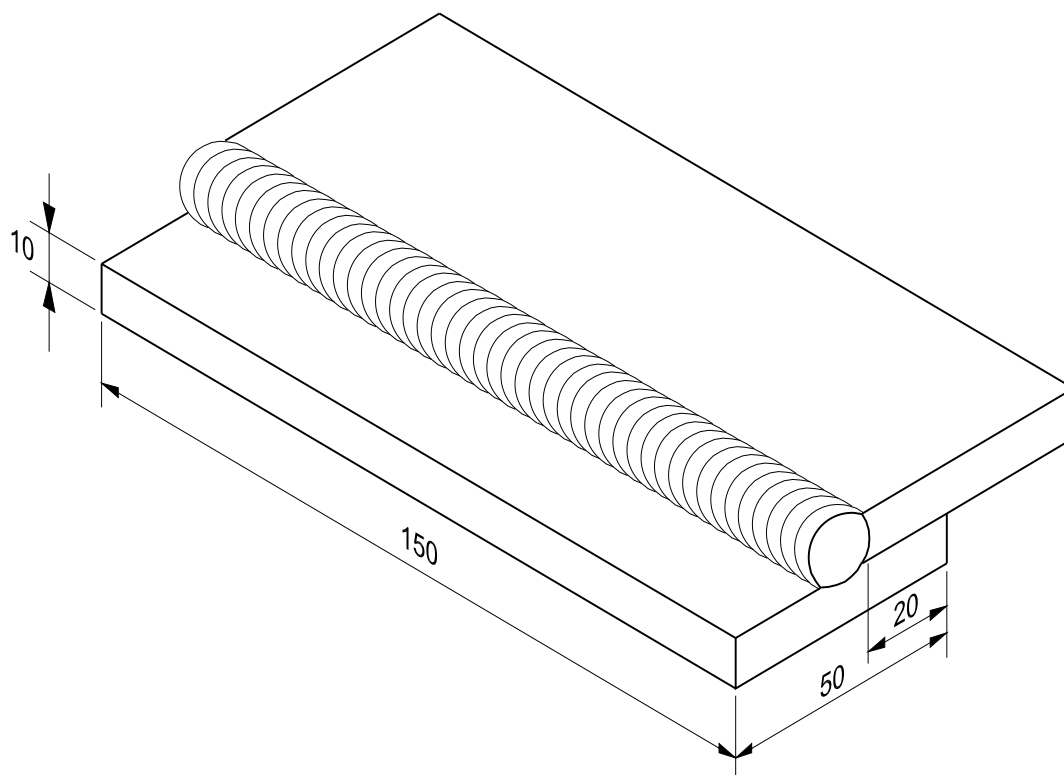


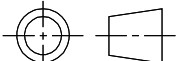
- slight convex bead with weld penetration at the root of the joint. (Fig 7)



**Fillet lap joint on MS plate 10mm thick in flat position (1F)-(SMAW-05)**

- Objectives:** At the end of this exercise you shall be able to
- prepare plate pieces by gas cutting and by grinding to size
  - set plates as a lap joint and tack weld at both ends
  - place the lap joint in a flat position for welding
  - deposit root run of proper size and ensure penetration
  - deposit the final covering run in the lap joint of proper leg size
  - clean and inspect the lap fillet weld for surface defects.



2	50 ISF 10 - 150		Fe 310 - W			1.2.22
NO.OFF	STOCK SIZE	SEMI-PRODUCT	MATERIAL	PROJECT NO.	PART NO.	EX. NO.
SCALE NTS	<b>FILLET LAP JOINT ON M.S PLATE 10mm THICK IN FLAT POSITION (1F)-(SMAW-05)</b>				TOLERANCE ±1	TIME 8Hrs
					WLN1222E1	



## Job Sequence

- Cut the plate pieces by gas cutting as per drawing.
- Grind the gas-cut edges to square.
- Remove the grinding burrs and clean the surfaces by wire brush.
- Set the pieces in the form of a lap joint as per drawing.
- Select DCEN polarity, in case of a DC machine.

### Wear protective clothing.

- Tack-weld on both ends.
- Set the lap joint in a flat position.
- Deposit root run by using a 3.15mm dia. medium coated M.S. electrode with 100-110 amps current.

Ensure an electrode angle of 45° with the fillet corner and 80° with the welding line.

- Remove the slag with a chipping hammer and clean with a wire brush.
- Use tongs to hold the job.
- Wear chipping goggle for the protection of eyes.
- Deposit the final covering run with a weave motion using a 4.00 mm dia. medium coated M.S. electrode with 150-160 amps welding current.

Prevent the upper edge of the plate from melting off.

- Remove the slag from the final weld and clean thoroughly.

Use a weld gauge to check the fillet size.

- Inspect the lap fillet weld for surface defects and size.

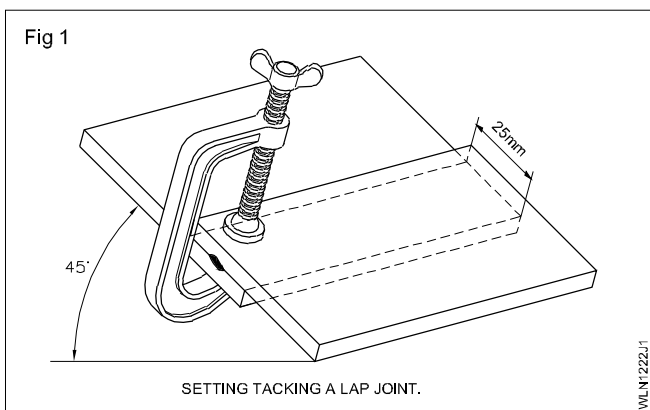
## Skill Sequence

### Lap fillet joint in flat position

**Objective:** This shall help you to

- prepare and weld lap fillet joint in flat position.

#### Setting and tacking the lap joint (Fig 1)



Set the lap joint with an overlap of 25mm.

The overlap may vary based on the plate thickness.

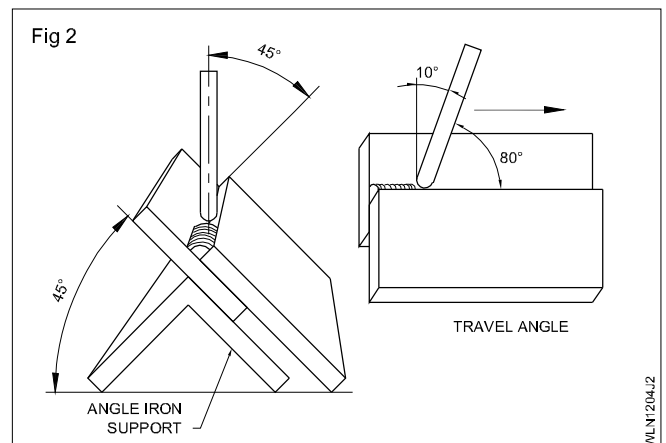
Tack-weld on both ends. (Fig 1) Ensure the 2 lapping surfaces are perfectly cleaned and they contact each other properly. Use a 3.15mmø MS electrode with 120 amp current for tacking.

Set the joint in a flat position using angle iron (Fig 2).

#### Welding the lap fillet joint in flat position

Deposit root run with a 3.15mmø medium coated MS electrode with 100-110 amp. current.

Maintain 80° angle to the line of the weld and 45° between the weld faces. (Fig 2)



Maintain a short arc to get uniform fusion and root penetration.

Avoid side-to-side movement of the electrode.

Deslag and clean the root bead thoroughly.

Deposit the final covering run with a 4mmø medium coated MS electrode and 160 amp current.

Give side-to-side movement to the electrode not more than 2.5 times its dia.

Use the same electrode angle as was used for the root bead.

**Prevent the upper edge of the plate from melting off by not allowing the arc to concentrate more on the upper edge.**

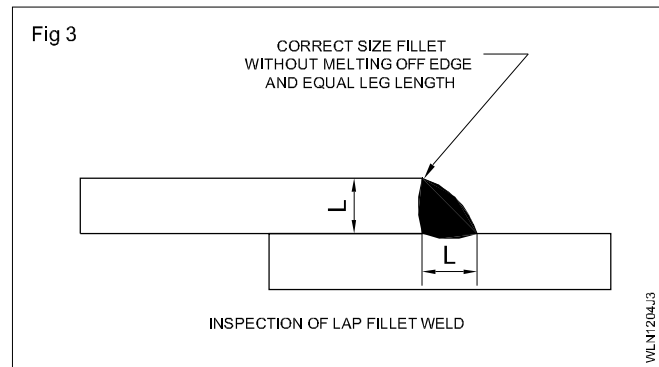
Remove the slag with a chipping hammer.

Clean the weld with a steel wire brush.

Inspect the lap fillet weld (Fig 3) and ensure:

- it has equal leg length with slight convexity

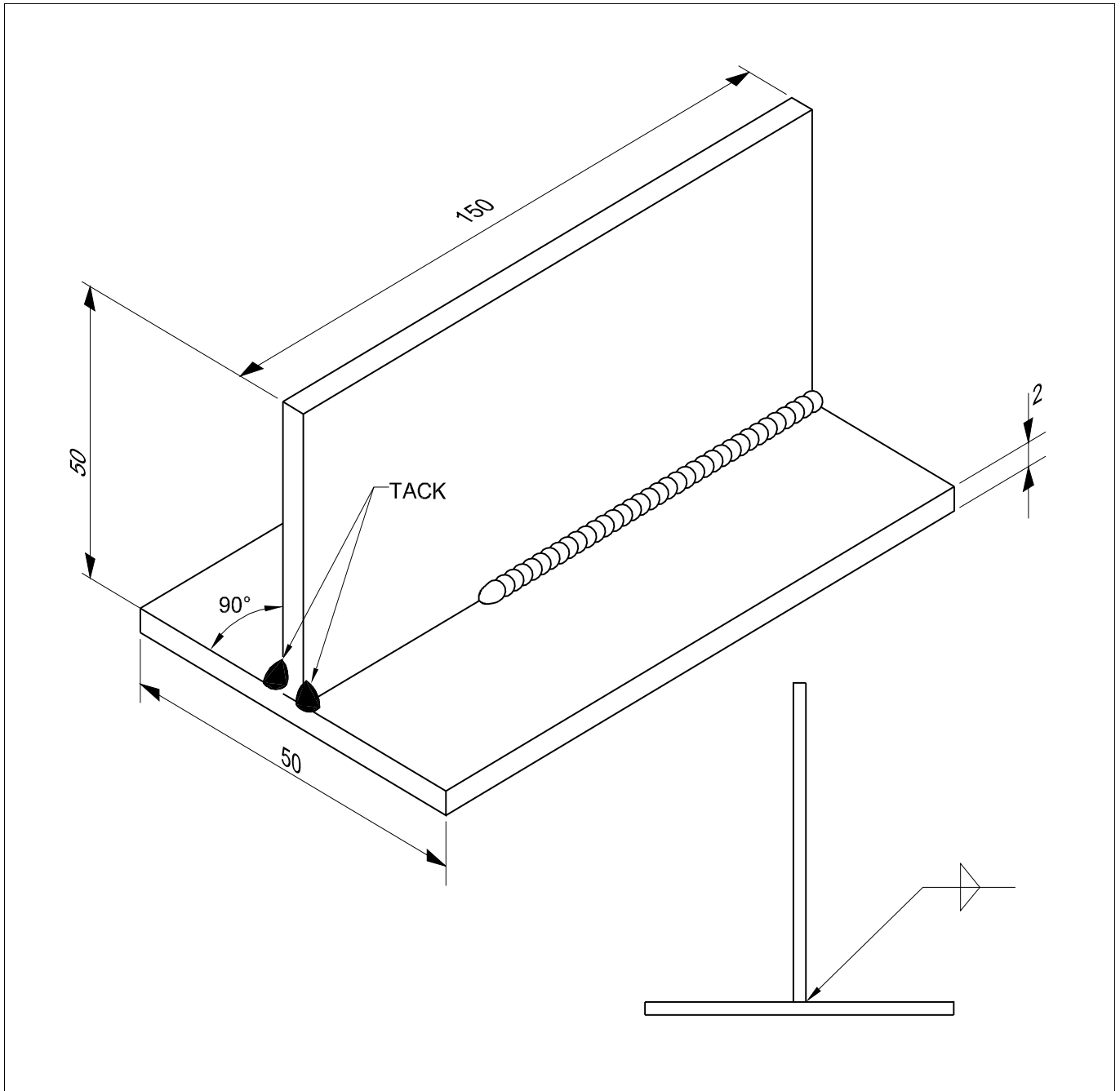
- the upper edge of the plate has not melted off
- it is free from surface defects.



**Fillet 'T' joint on M.S. sheet 2mm thick in flat position (1F)-(OAW-06)**

**Objectives:** At the end of this exercise you shall be able to

- set and tack the job to form 'T' fillet joint and manipulate the blow pipe and the filler rod properly
- weld a 'T' fillet joint using recommended filler rod and nozzle size
- clean and inspect the weldments for defects.



1	ISST 50 x 2 - 150		Fe 310 - W			1.2.23
NO.OFF	STOCK SIZE	SEMI-PRODUCT	MATERIAL	PROJECT NO.	PART NO.	EX. NO.
SCALE NTS	<b>FILLET "T" JOINT ON M.S. SHEET 2mm THICK IN FLAT POSITION (1F)-(OAW-06)</b>				TOLERANCE ±0.5	TIME 8 Hrs
					CODE NO. WLN1223E1	

## Job Sequence

- Prepare job pieces as per drawing.
- Clean the surface and edges of the sheets to be welded.
- Set the sheets in the form of a 'T' joint on the welding table.
- Wear safety apparels and gas welding goggles.
- Set the gas welding plant, fix nozzle No. 5 and set pressure at 0.15 kg/cm for both gases.
- Set the neutral flame, tack at both ends of the joint also in the center with a 1.6 mm C.C.M.S. rod.
- Check the alignment of the joint with a try square and clean the tacked portion.
- Keep the job on the welding table in a flat position.
- Start welding with the leftward technique and melt the right hand end of the joint.
- Fuse the area to be welded (i.e. equally the part of the

horizontal sheet and the vertical sheet) and apply the filler rod in the molten pool to form a fillet weld at the joint.

- Maintain correct travel speed, manipulate the blowpipe and filler rod to produce a uniform weld bead.
- Stop the weld at the left hand end of the joint after filling up the crater at the end of the weld.
- Extinguish the flame, cool the nozzle and place the blowpipe at its place.
- Clean the weldment and inspect for defects in the fillet weld.

### Visual inspection

- Slight convexity, uniform width, uniform ripples indicate a good weld bead. A weld without undercut, overlap, porosity, etc. will ensure a good quality weld.
- Weld on the other side of the joint for more practice.

## Skill Sequence

### Fillet weld 'T' joint on MS sheet 2.00mm in flat position

**Objective:** This shall help you to

- **prepare and fillet weld 'T' joint on MS 2.00mm in flat position.**

'T' fillet joints are used extensively in industry i.e., Capital Goods & Manufacturing of underframes, vertical supporters for oil and water containers and other similar structural work.

It is an economical joint with very little edge preparation but difficult to weld without defects (i.e. unequal leg length, undercut, etc.) unless the operator gets proper practice.

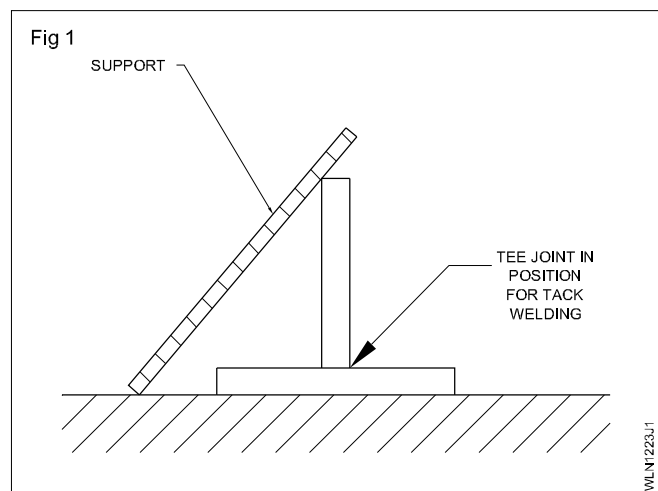
Root penetration must be obtained completely and undercut is to be avoided.

#### Setting and tacking the job pieces

Place the pieces on the welding table as 'T' joint.

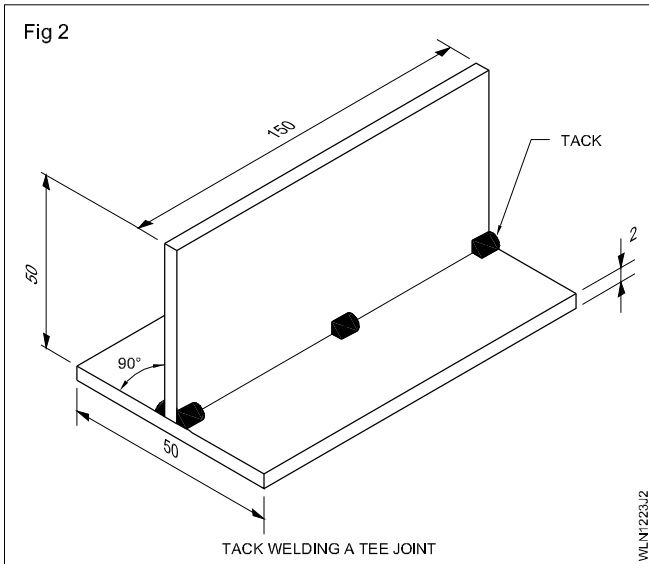
Hold the pieces in position using support. (Fig 1)

Ensure the vertical piece is perpendicular to the horizontal



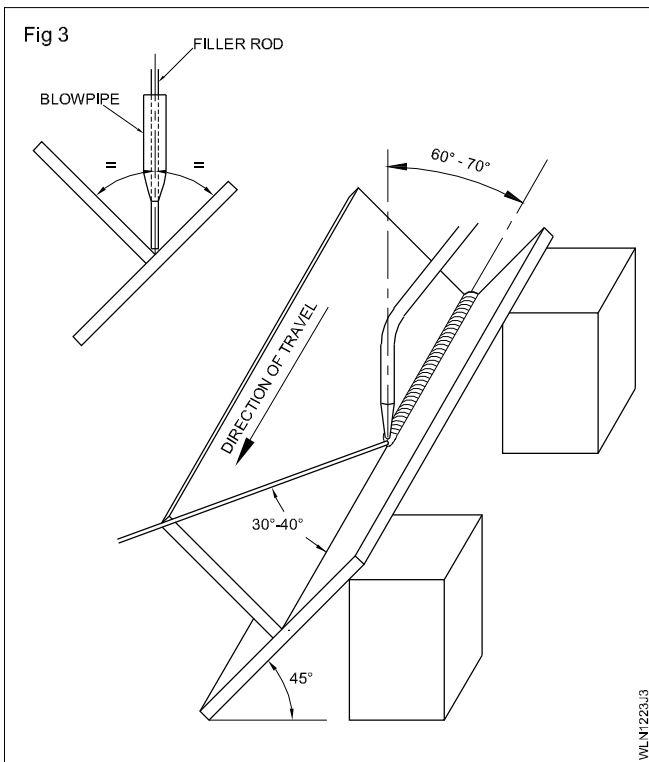
piece without gap of the joint.

Check with a try square for perpendicularity.



Tack weld the joint at both ends (Fig 2) on one side of the joint.

### Welding of fillet 'T' joint in flat position (Fig 3)



Place the tack welded in flat position by tilting and supporting it. Fig 3.

Start welding at the right hand end of the joint by fusing the tack weld and the parent metal to form a molten pool. Keep the blowpipe in the leftward direction at an angle of 60° to 70° and the filler rod at an angle of 30° to 40° to the line of travel. The blow pipe and filler rod should be held at 45° between the 2 surfaces of the joint. This will ensure root penetration. Watch the molten metal closely to make sure that both pieces melt uniformly. Change the angle of the blowpipe if the pieces do not melt uniformly. When the molten pool is formed add the filler rod in the center of molten pool. Give slight side-to-side movement to the flame (blowpipe) and a piston like motion to the filler rod.

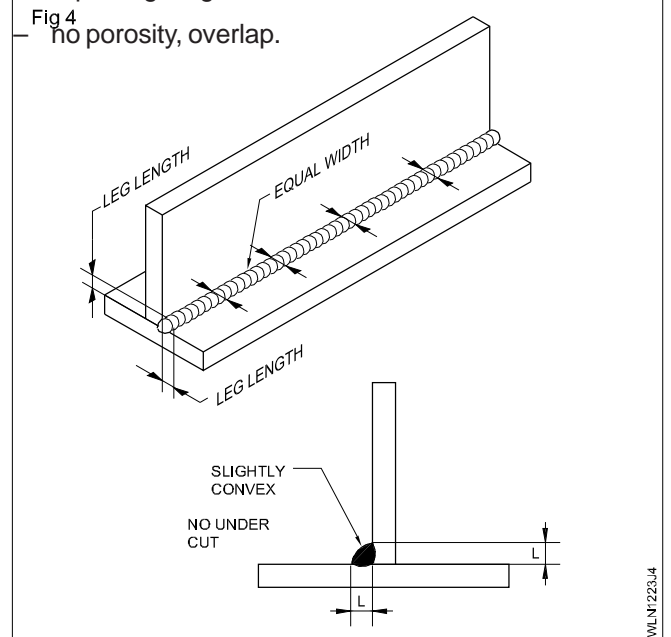
Adjust the rate of travel of the blowpipe and the filler rod to secure even penetration at the root and into both sheets, and to produce a fillet weld of equal leg length.

### Visual inspection (Fig 4)

Clean the weldment and inspect for:

- uniform weld size and shape of bead (reinforcement and contour slightly convex)

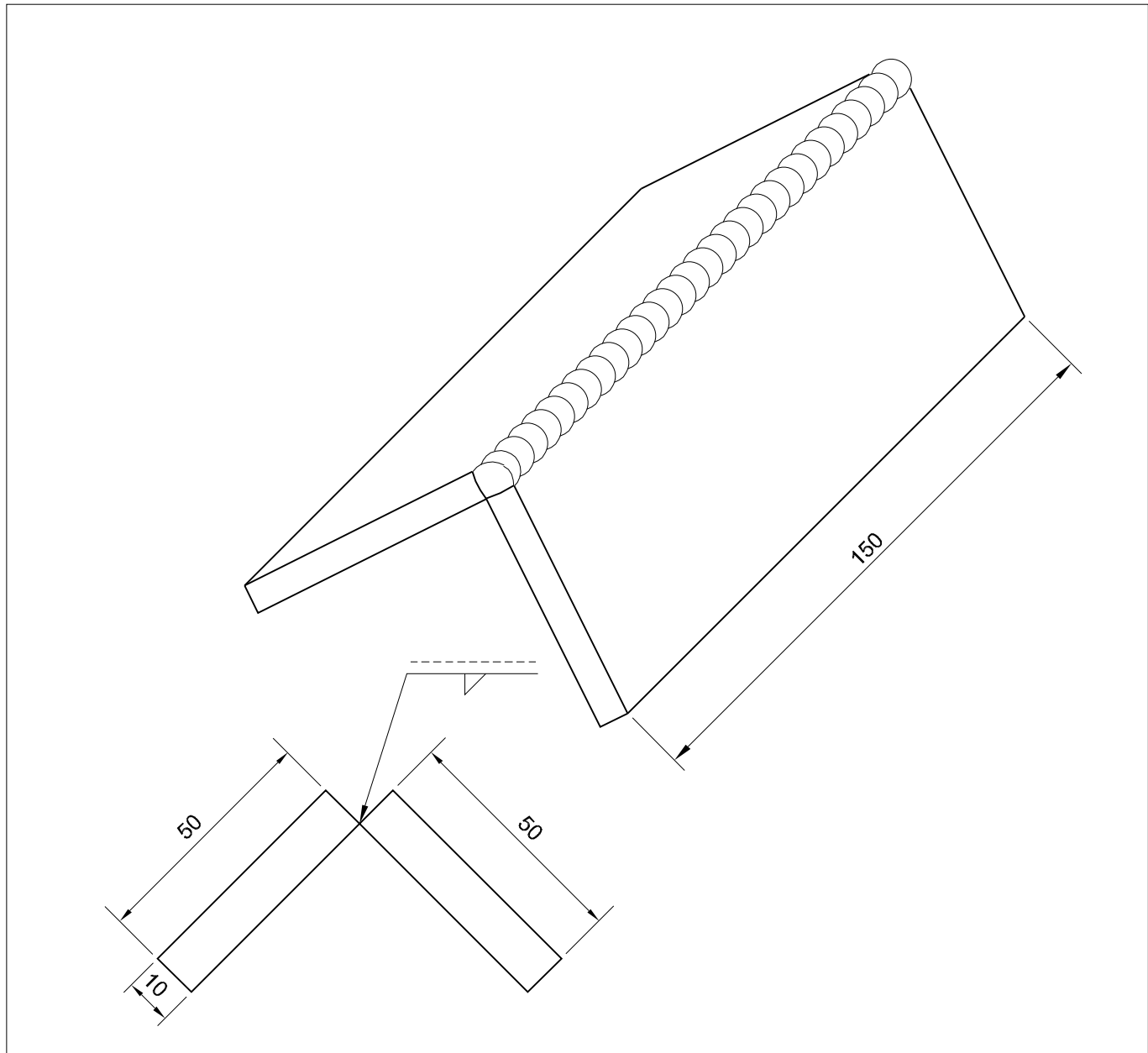
equal leg length, no undercut at the toes of the weld.  
no porosity, overlap.



**Open corner joint on MS plate 10mm thick in flat position (1F)-(SMAW-06)**

**Objectives:** At the end of this exercise you shall be able to

- set the plates to form an open corner joint at 90° with specified root gap in flat position
- tack weld the pieces as an open corner joint at both ends
- deposit root run in the corner joint with the formation of a KEYHOLE and obtain complete penetration
- deposit uniform covering layers in the corner joint using weaving of electrode and complete the weld
- inspect the welded joint for penetration, reinforcement and throat thickness.



2	50ISF10 - 150	-	Fe 310 - W	-	-	1.2.24
NO.OFF	STOCK SIZE	SEMI-PRODUCT	MATERIAL	PROJECT NO.	PART NO.	EX. NO.
SCALE NTS	<b>OPEN CORNER JOINT ON M.S PLATE 10mm THICK IN FLAT POSITION (1F)-(SMAW-06)</b>				TOLERANCE ±1	TIME 10Hrs
					CODE NO. WLN1224E1	

## Job Sequence

- Prepare job plates to size as per drawing.
- Clean the joining edges and surfaces of plates.
- Set the plates as an open corner joint with a root gap of 2.5 mm using an angle iron jig.
- Select DCEN polarity, if a DC generator is used.
- Tack the joint pieces at both ends using  $\varnothing$  3.15 mm medium coated MS electrode and 100-110 amps current at the inside of the joint.
- Ensure safety apparels are worn. Use a proper method to control distortion.
- Clean the tacks, check alignment and reset the joint, if required.
- Set the joint on the welding table in a flat position.
- Deposit root run in the joint by forming a keyhole and obtain complete penetration.
- Deslag and clean the root run and inspect root penetration.

**Ensure the crown of penetration is not more than 1.6 mm in height.**

- Grind and dress the face of the root run, if required.
- Set the welding current 160 amps for 4mm  $\varnothing$  medium coated M.S. electrode.
- Deposit an intermediate layer i.e. second run over the root run with slight weaving motion using 4mm $\varnothing$  electrode.
- Clean the intermediate layer thoroughly and inspect for faults. Rectify the defects, if any.
- Deposit the final layer to the weld size using the same current setting, electrode and weaving motion as used for the second layer.
- Clean the final layer for inspection.
- Inspect the corner fillet weld:
  - to ensure uniform and correct reinforcement
  - to ensure that the weld face is free from porosity, slag inclusion, unfilled crater, overlap and edge of plate melted off/insufficient throat thickness.

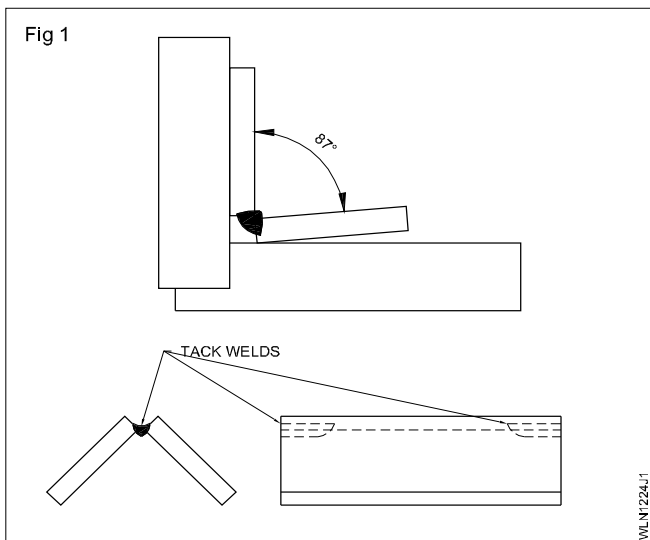
## Skill Sequence

### Open corner joint on MS plate 10mm thick in flat position (1F)

**Objective:** This shall help you to

- **prepare and weld corner joint on MS plate 10mm thick in flat position.**

#### Setting and tacking plate pieces for open corner joint (Fig 1)



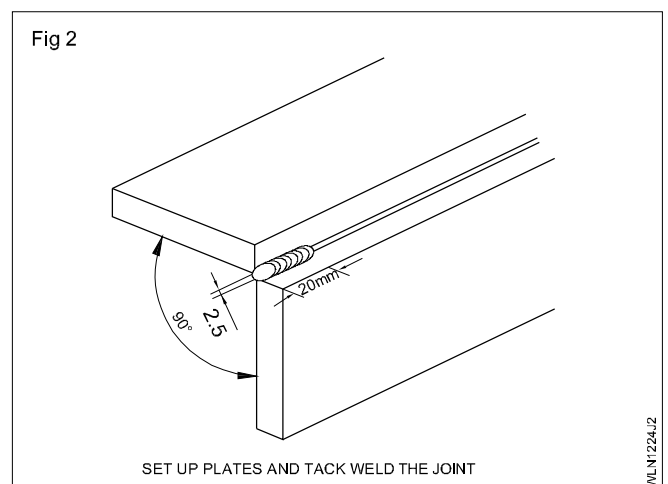
Set the plates as an open corner joint on the table with parallel root gap of 2.5mm throughout the joint. The angle between the plates is kept at 87° to control the distortion.

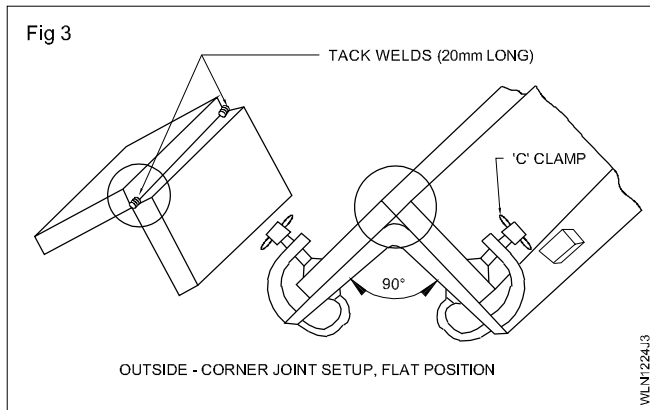
The angular distortion is normally taken as 1° per run.

Check the alignment of the joint with a try square. (Fig 1)

Another method to control distortion is, set the angle at 90° and use a right angled iron fixture to minimize the distortion. Fig 3.

Tack weld the corner joint from inside using a MS electrode  $\varnothing$  3.15mm and 100 - 110 amps current range. Tack weld at both ends with max tack length of 20mm each. (Fig 2)





**Ensure that the joining edges are perfectly clean and safety apparels are worn.**

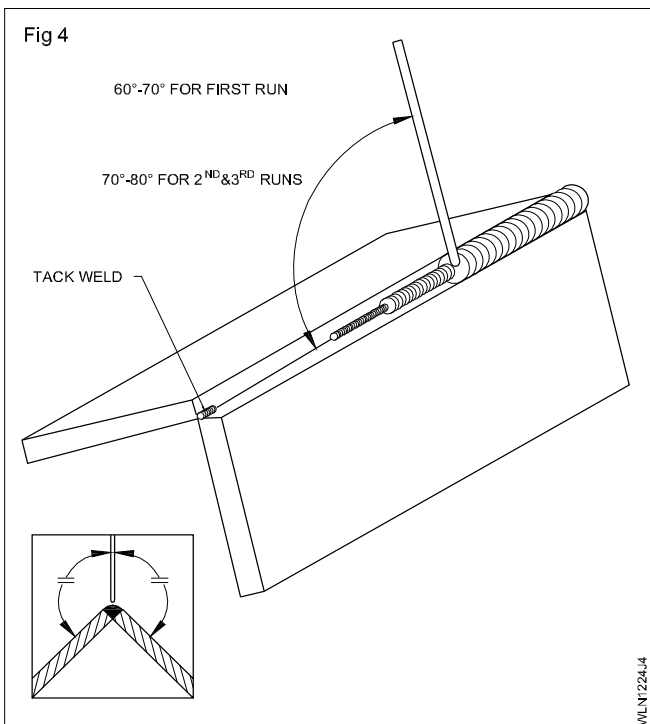
Deslag and clean the tacks using chipping hammer and wire brush.

### Deposition of root run

Set the joint in a flat position.

Deposit root run in the bottom of the corner by

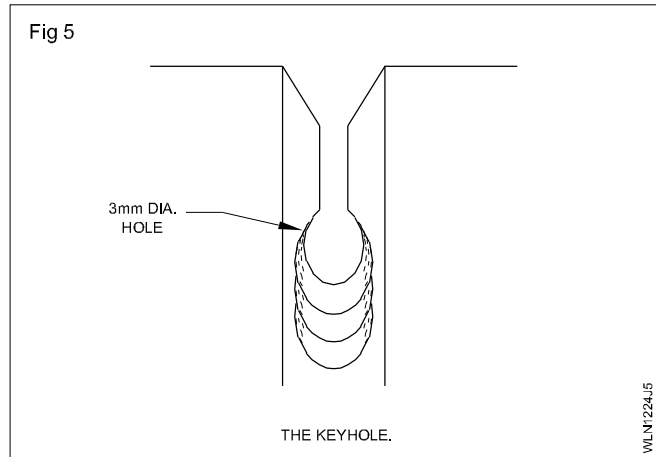
- using a M.S. electrode  $\varnothing 3.15$  and welding current 110 to 120 amps.
- maintaining a slightly short arc
- positioning the electrode vertically between the edge and  $60^\circ - 70^\circ$  with the weld line. Fig 4



- forming a keyhole near the weld crater of the tack weld to ensure complete penetration. Fig 5
- maintaining travel speed similar to the speed used for straight beading. Clean the root run thoroughly and observe penetration.

Ensure no slag particles are adhering on the root run.

The crater is to be properly filled in each run.



### Deposition of covering layers

Deposit 1st covering layer i.e., the second run using a  $\varnothing 4.00$  mm medium coated MS electrode and 160 amps welding current. A weaving motion for the electrode has to be given to ensure enough metal is deposited in the groove and both edges of the plates are fused.

Ensure that the electrode angles are as shown in Fig 4. Uniform medium arc length, uniform normal travel speed should be maintained.

Clean the slag from the 1st covering layer thoroughly.

Ensure all the surface defects are rectified.

Deposit 2nd (final) covering layer i.e. the third run using:

- $\varnothing 4$  mm M.S. electrode and 160 amps welding current
- wider weaving motion to the sides of corner joint
- a slower rate of travel than the 1st covering layer.
- Use the same angle of electrode and arc length as used in 1st covering layer. Fig 4.

Each movement of the weave from one side to the other will deposit more metal, and that takes more time.

Ensure restarting and stopping of the beads correctly.

The usual defect on the final layer of weld is 'edge plate melted off'. This can be eliminated if care is taken to weave the electrode to the required extent so that the edges are just fused. The arc should not be focused on the edges at all.

### Inspection of fillet weld in corner joint (Fig 6)

Clean the weldment thoroughly.

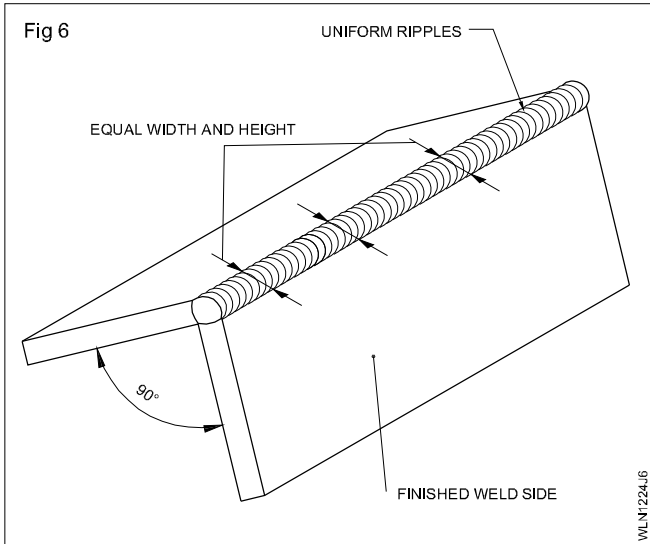
Check the angle between the plates for  $90^\circ$ .

Check each run/layer for the following weld characteristics.

Width and height: Uniform.

Appearance: Smooth with close ripples.





Size: Full fillet without excessive reinforcement.

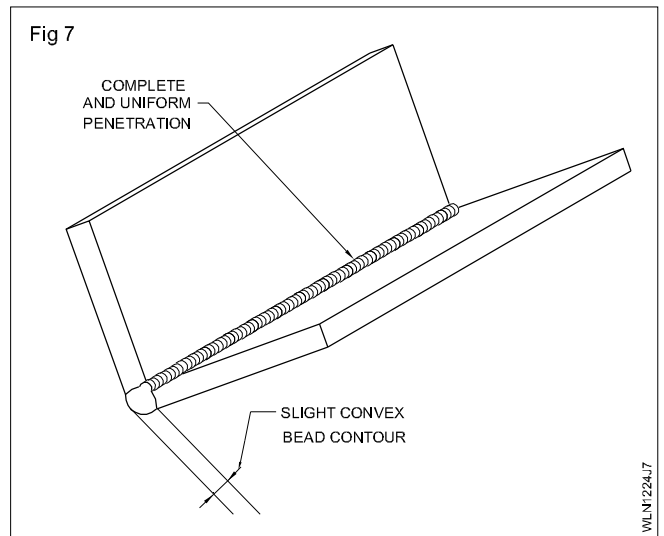
Face of welds: Root run and 1st covering layer flat, final layer slightly convex.

Edges of welds: Good fusion, no undercut, no overlap.

Starts and stops: Free of depression and high spots, craters filled.

Back side: Complete and uniform penetration. (Fig 7)

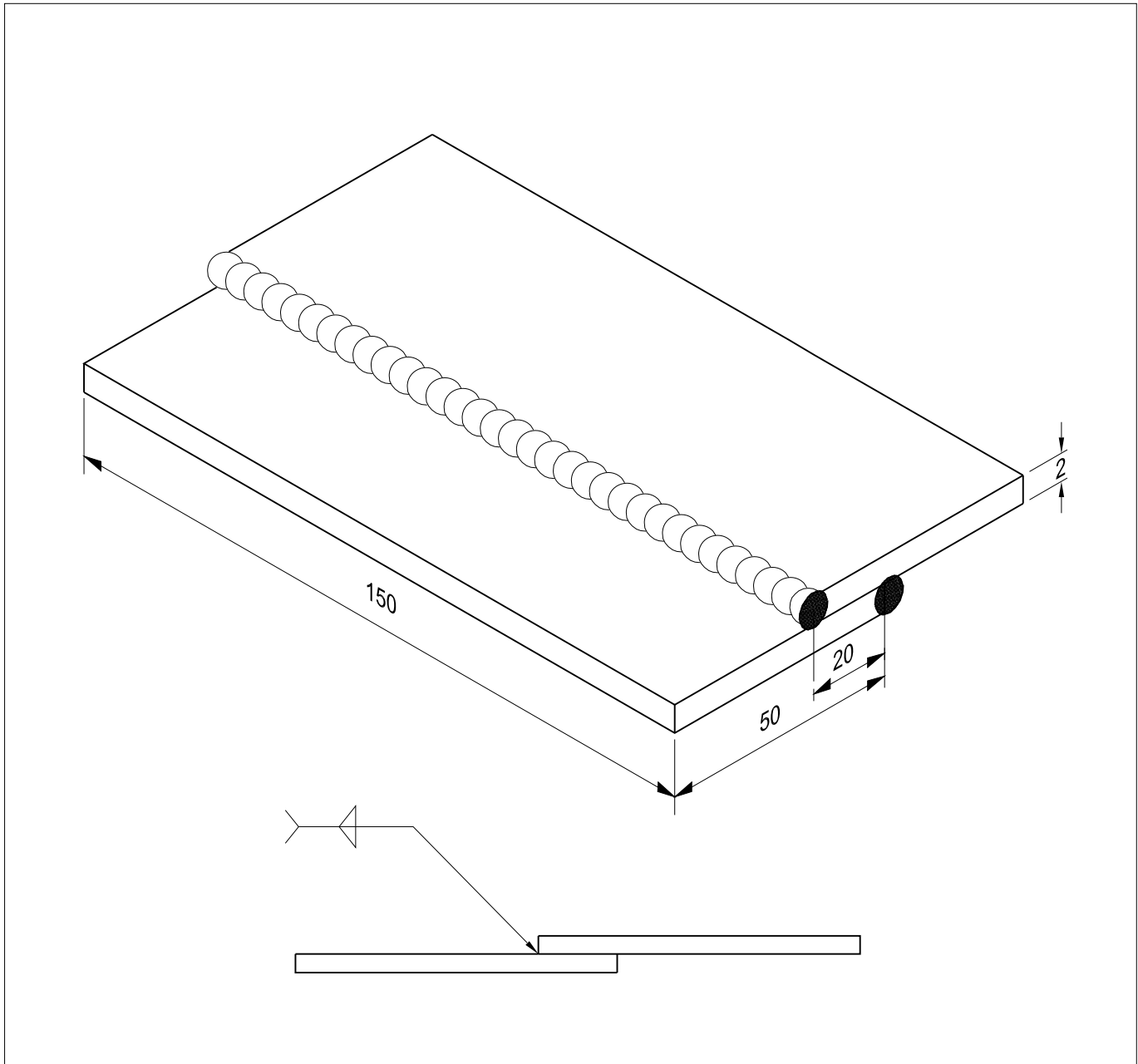
Surrounding plate surfaces: Free of spatter.

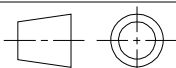


**Fillet lap joint on MS sheet 2mm thick in flat position (1F)-(OAW-07)**

**Objectives:** At the end of this exercise you shall be able to

- set and tack the job to form a lap fillet joint with recommended overlap
- weld lap fillet joint using correct size filler rod and nozzle in flat position
- clean and inspect the weldments of the lap fillet for weld defects.



2	ISST 50 x 2 - 150		Fe 310 - W			1.2.25
NO.OFF	STOCK SIZE	SEMI-PRODUCT	MATERIAL	PROJECT NO.	PART NO.	EX. NO.
<p>SCALE NTS</p>  <p><b>FILLET LAP JOINT ON M.S.SHEET 2mm THICK IN FLAT POSITION (1F)-(OAW-07)</b></p>					TOLERANCE ±1	TIME 10Hrs
					CODE NO. WLN1225E1	

## Job Sequence

- Prepare the job as per drawing and clean the edges.
- Set the job on the welding table to form a lap joint.
- Set the gas welding plant, fix nozzle No. 5 and set a pressure of 0.15 kg/cm for both gases.
- Select a C.C.M.S. filler rod 1.6 mm  $\varnothing$  for tacking and 3.00 mm  $\varnothing$  for welding.

**Wear safety apparels and use gas welding goggles.**

- Set the neutral flame.
- Tack the pieces at both ends and also in the center using a 1.6 mm  $\varnothing$  filler rod.
- Check the alignment of pieces, clean the tacks, and place on the welding table in a flat position.
- Start welding, using leftward technique with the correct angle of the blowpipe and (3mm  $\varnothing$ ) filler rod.

- Fuse the edges uniformly, add filler metal to obtain correct root fusion and reinforcement, and proceed towards left. Don't concentrate the flame on the top member in the lap joint.
- Maintain correct travel speed, manipulation of blowpipe and filler rod to produce uniform weld bead.
- Stop at the left end, after filling the crater and complete the weld.
- Extinguish the flame, cool the nozzle in water and place the blowpipe at its place on the cylinder trolley.
- Clean the welded joint with a wire brush.

**Visual inspection:** Inspect for correct size of fillet weld, slight convexity, uniform width and height, uniform ripples without edge of plate melted off defect and other surface defects.

Weld the job from the other side also following the same steps.

Repeat the exercise till you get good results.

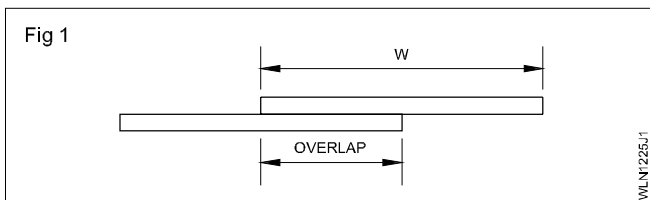
## Skill Sequence

### Lap weld joint on MS sheet 2.00 mm in flat position

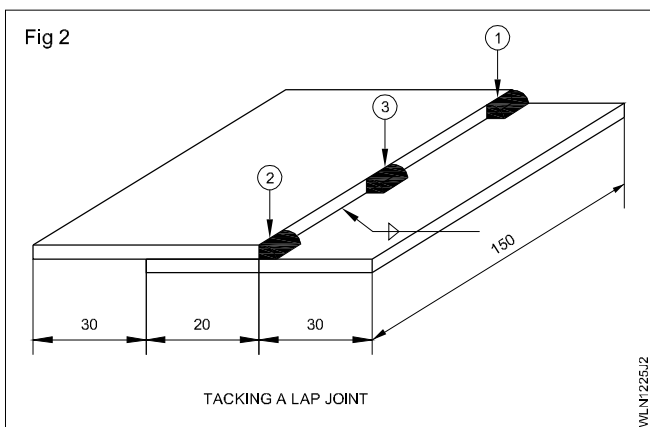
**Objective:** This shall help you to

- prepare and lap weld joint on MS plate 2.00mm in flat position.

Set and tack the job pieces in correct alignment with proper overlapping of pieces. (Fig 1)

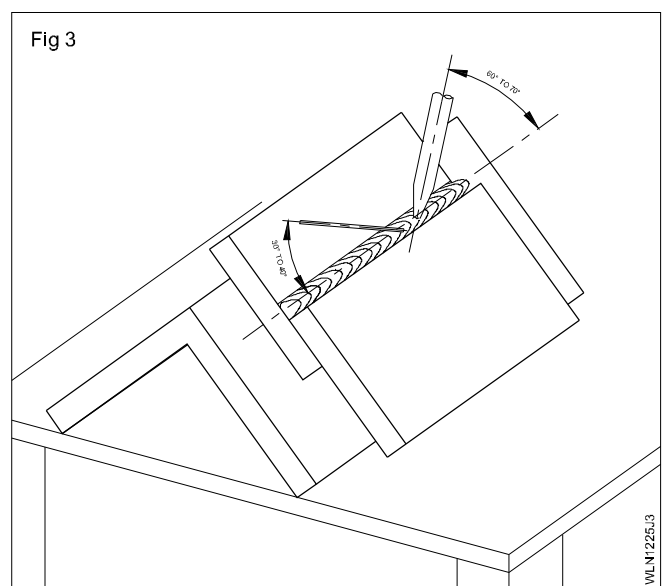


Place the tack welds at correct locations. (Fig 2)

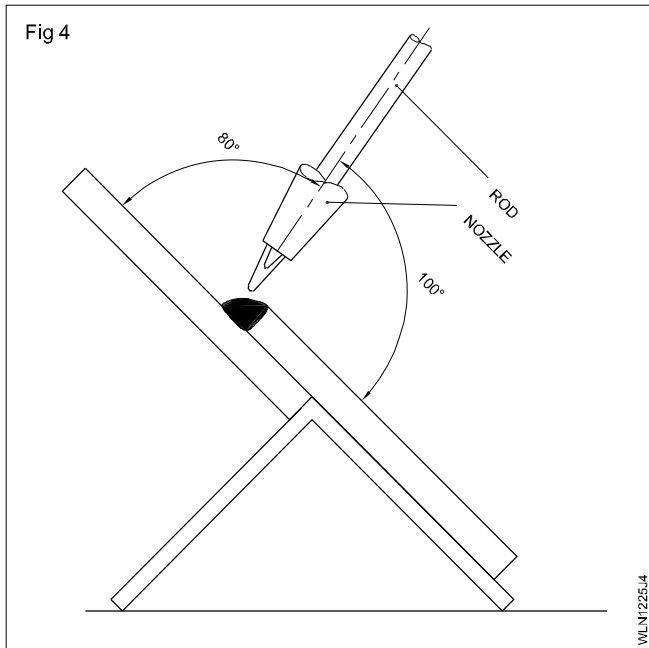


Weld a uniform, well penetrated, correct size fillet lap weld in flat position by

- proper positioning of the joint (Fig 2)
- proper angle of the blowpipe and filler rod (Figs 3 & 4)



- proper manipulation of the blowpipe and filler rod.
- using leftward welding technique.

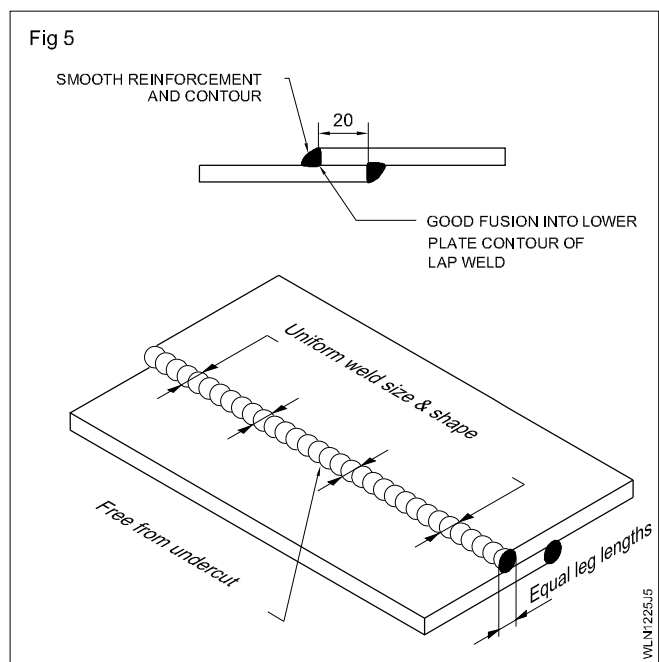


**Avoid movement of blow pipe flame nearer to the edge of the top plate. This will avoid edge of the plate melted off defect.**

- maintaining uniform travel speed and feed.

Clean the weldment and inspect for: (Fig 5)

- uniform weld size and shape of whole length (reinforcement and contour) of the joint.



- equal leg length
- no undercut at the toe of weld
- no fusing of the top plate edge to undersize
- smooth ripple appearance
- proper crater filling.

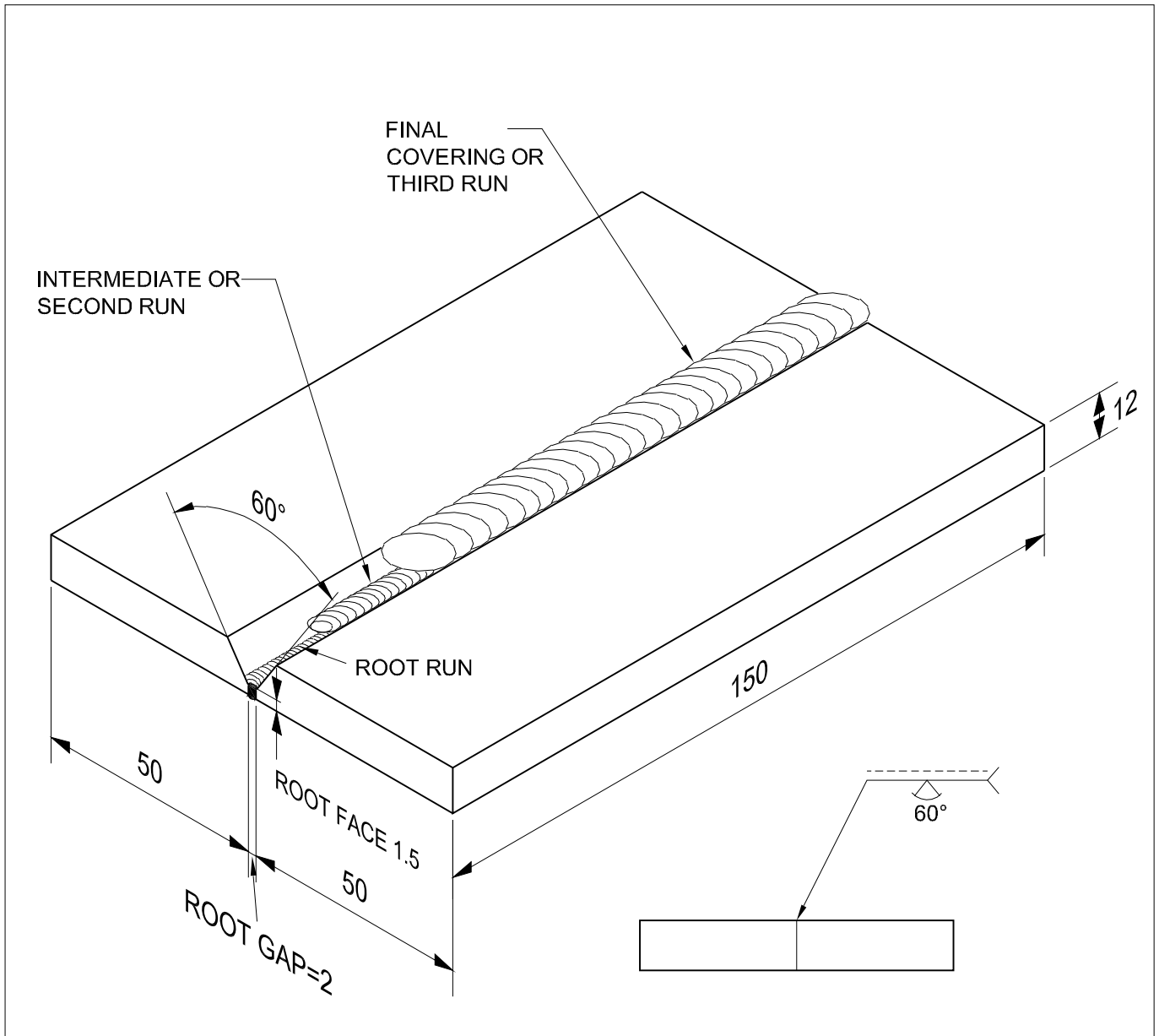


Scan the QR Code to view the video for this exercise

**Single "V" butt joint on MS plate 12mm thick in flat position (1G)-(SMAW-07)**

**Objectives:** At the end of this exercise you shall be able to

- bevel the plate edges by gas cutting for single V butt joint
- grind the gas-cut bevel edges with proper root face for single V butt joint
- set the plates with a root gap of 2mm and proper distortion allowance for single V butt joint
- control arc blow
- deposit root run in single V butt joint to ensure complete penetration
- deposit intermediate and final covering runs in single V butt joint to obtain proper fusion and reinforcement
- clean and inspect the groove weld for surface defects and uniform root penetration.



4	50 ISF 12 - 150		Fe 310 - W			1.2.26
NO.OFF	STOCK SIZE	SEMI-PRODUCT	MATERIAL	PROJECT NO.	PART NO.	EX. NO.
SCALE NTS	<b>SINGLE "V" BUTT JOINT M.S. PLATE 12mmTHICK IN POSITION FLAT POSITION (1G)-(SMAW-07)</b>				TOLERANCE ±1	TIME 13 Hrs
					WLN1226E1	

## Job Sequence

- Straight cut two 12mm thick plates by gas cutting as per drawing and grind them to size.
- Bevel the edges of each plate to 30° angle by gas cutting and file the root face as per drawing. Refer Ex.No.2.04 for cutting the bevel.
- Clean the plates from dirt, water, oil, grease, paint etc.
- Keep the plates inverted in the form of a butt joint with proper root gap.
- Maintain a distortion allowance of 1.5° on each side of the joint.
- Wear all protective clothing.
- Use a 3.15mm medium coated MS electrode and set 110 amperes current. In case of DC welding machine connect the electrode cable to the negative terminal of the machine.
- Tack weld on the back side of the plates at the ends. The length of tack should be 20mm.
- Deslag the tack weld and clean.
- Position the tack welded job on the table in flat position (the single V portion facing up)
- Deposit the root run and fill the crater as done for weld square butt joint. (Ex.No.3.06)
- Take special care to maintain key hole to ensure proper melting of root face and root penetration.
- Deposit the second run/intermittent run using 4mm  $\varnothing$  medium coated electrode and 150-160 ampere current, short arc and proper weaving of the electrode. Avoid excessive weaving and ensure normal travel speed.
- Fill the crater wherever necessary.
- Deslag.
- Deposit the third run/covering run using the same parameter and technique used for 2nd run. Ensure a proper reinforcement of 1 to 1.5mm and avoid undercut.
- Inspect for any surface weld defect.

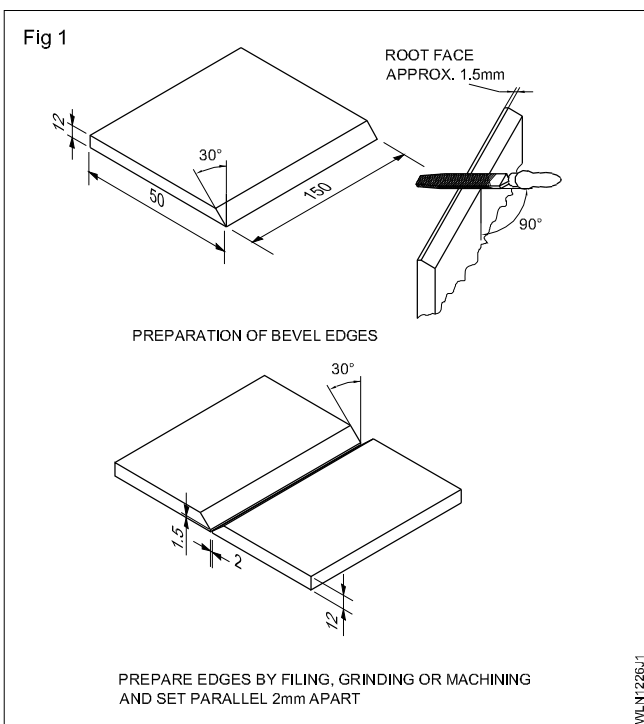
## Skill Sequence

### Welding of single 'V' butt joint MS plate 12mm thickness in flat position

**Objective:** This shall help you to

- weld single V butt joint MS plate 12mm in flat position (1G).

#### Preparation of the pieces (Fig 1)



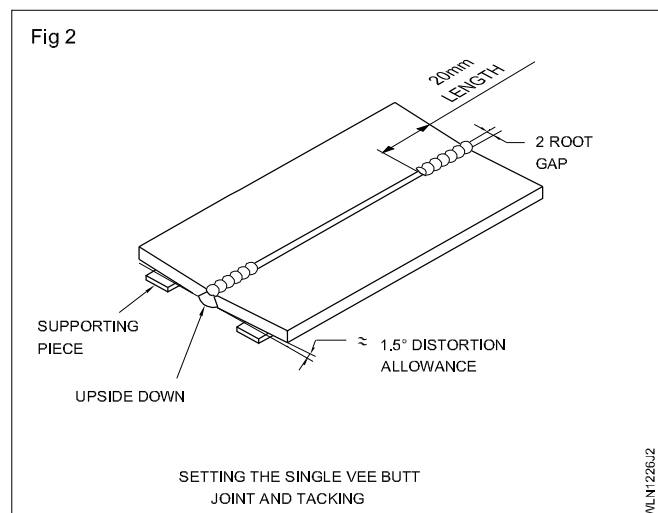
Cut a 30° bevel on each piece using oxy-acetylene cutting.

Grind the bevel edges to remove oxide deposits on the bevel.

Prepare a uniform root faces 1.5 mm by filing on both the beveled edges.

#### Setting the single V butt joint and tacking

Keep the bevel edges upside down with a root gap of 2mm, and 3° distortion allowance. (Fig 2) using suitable support. i.e. 1.5° on each side of the joint.

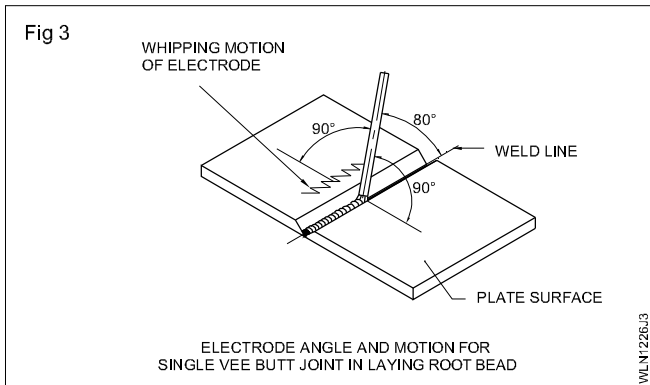


Tack-weld on both ends. (20mm long)

**Ensure safety apparels are worn.**

Place the joint in flat position after tacking.

### Deposition of root bead (Fig 3)



Deposit root bead using a 3.15 dia. M.S. electrode and 110 amps welding current.

Proceed with a uniform normal speed holding a short arc.

Keep the electrode angle (as shown in Fig 3) at 80° to the line of weld.

Give a whipping motion to the electrode to maintain the size of the KEYHOLE for correct penetration.

Clean the root bead, and observe penetration.

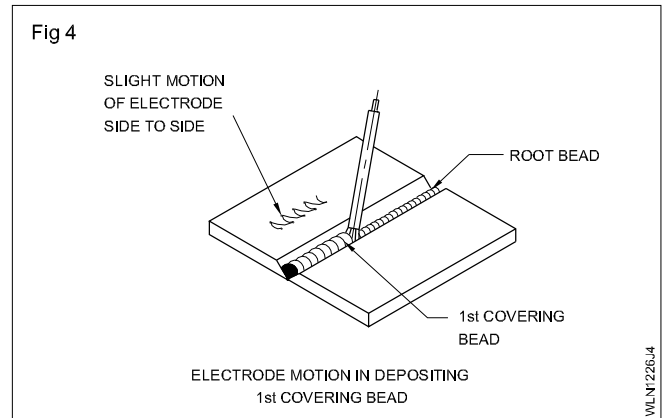
### Deposition of hot pass & covering beads (Fig 4)

Deposit the 1st covering bead using a 4.00mm dia medium coated M.S. electrode and 160 amps welding current.

Proceed with a uniform speed, holding a normal arc and a side-to-side weaving motion to the electrode.

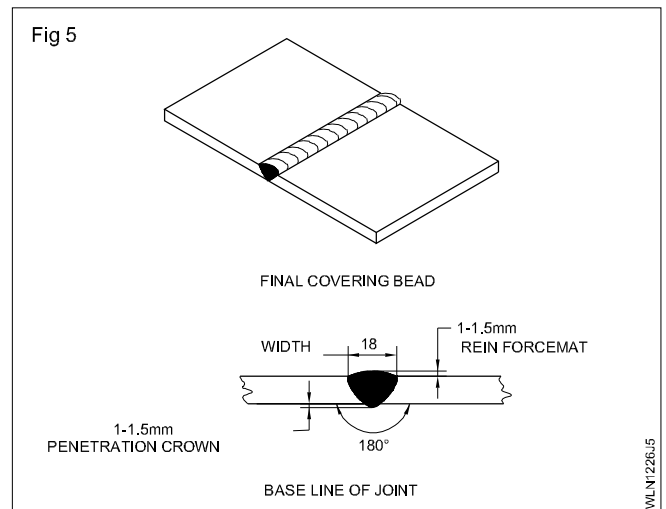
Ensure the electrode angle is the same as it was for the root bead.

Clean the bead thoroughly and grind the humps in beads (if present).



Rectify possible defects, if any.

### Deposition of final/covering bead (Fig 5)



Deposit the final covering bead using a 5.00mm M.S. electrode, 220 amps welding current, and imparting a wider side-to-side weaving motion to the electrodes. Pause (stop) the electrode weaving at the toes of the weld so that undercut defect will get eliminated.

Follow the other steps as done for the 1st covering bead.

### Cleaning and inspection

Clean the welded joint thoroughly from both sides.

Inspect the weld size, surface defects, root penetration and distortion.

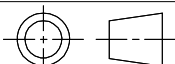
**Testing of weld joint by visual inspection (I&T-01)**

**Objectives:** At the end of this exercise you shall able to:

- observe the given sample of weld joint visually
- study the weld joint and identify the defects
- prepare the inspection repeat as given format.

WELD SAMPLE - BEAD	OBSERVATIONS ON WELD BEAD
<p>TASK - 1</p>  <p>SAMPLE-1</p>	
 <p>SAMPLE-2</p>	
 <p>SAMPLE-3</p>	

**Note:** Instructor to provide weld samples to trainees to record the observation on the weld beads.

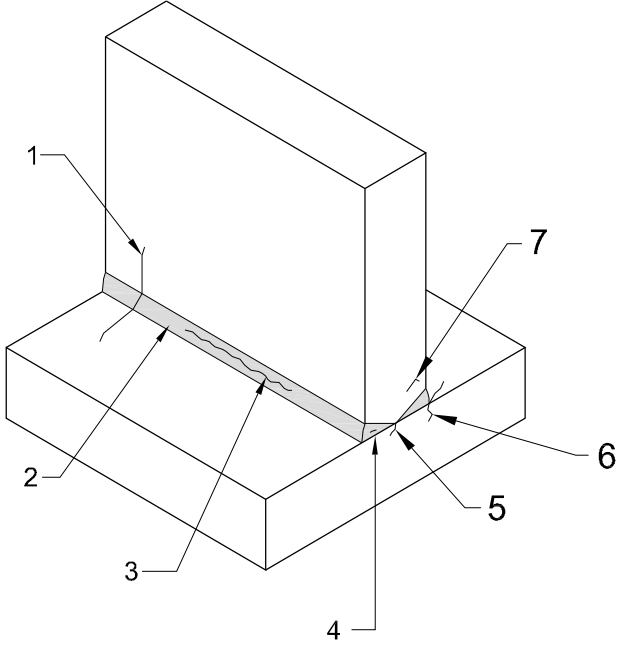
1	-	-	-	-	-	1.3.27
NO.OFF	STOCK SIZE	SEMI-PRODUCT	MATERIAL	PROJECT NO.	PART NO.	EX. NO.
SCALE NTS	<b>TESTING OF WELD JOINT BY VISUAL INSPECTION (1&amp;T-01)</b>				TOLERANCE ±1	TIME 1 Hrs
					CODE NO. WLN1327E1	



**Task**

- 1 Observe the given sample of weldment.
- 2 Study the weld joint and identify the defect.
- 3 Record the name of defect in weld against each sample.

**Note: Instructor to provide weld samples and ask trainees to record the defect.**

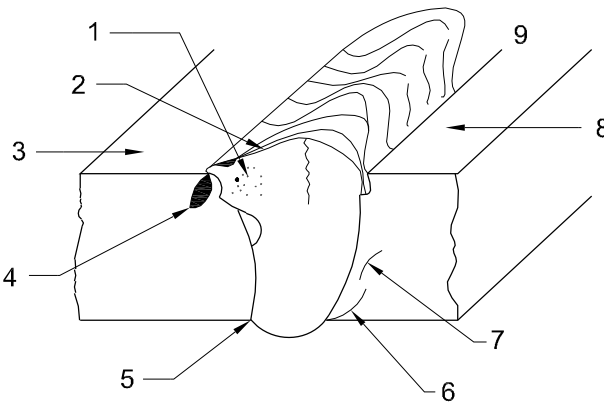
WELD SAMPLE - FILLET JOINT	NAME OF DEFECT
<p>TASK - 2</p>  <p><b>Note: Actual samples to be given by instructor for further study.</b></p>	<ol style="list-style-type: none"> <li>1 Spatters</li> <li>2 Crack</li> <li>3 Parent metal</li> <li>4 Crater</li> <li>5 Penetration</li> <li>6 Undercut</li> <li>7 Fusion Penetration</li> <li>8 Parent Metal</li> <li>9 Chamfering Area</li> </ol>

WLN1327E2

**Task**

- 1 Observe the given sample of weld joint.
- 2 Study the weld joint and identify the defect.
- 3 Record the name of defect in weld joint against each sample.

**Note: Instructor to provide weld samples and ask trainees to record the defects.**

WELD SAMPLE - BUTT JOINT	NAME OF DEFECT
<p>TASK - 3</p> 	<ol style="list-style-type: none"> <li>1 Spatters</li> <li>2 Crack</li> <li>3 Parent metal</li> <li>4 Crater</li> <li>5 Penetration</li> <li>6 Undercut</li> <li>7 Fusion Penetration</li> <li>8 Parent Metal</li> <li>9 Chamfering Area</li> </ol>

WLN1327E3

### Task 1: Inspection of weld bead

#### Job Sequence

- Study the given weld sample for inspecting the bead under proper lighting.
- Observe the weld bead using magnifying glass for (2-2.5) any deviation on straight and uniform welding.
- Record the deviations by visually observed in this welded sample 1 as slag inclusion and discontinuity on the weld bead.
- Record the observations in the register with details.
- On sample 2, it is observed that porosity along the length of bead, with spatters, along the bead of weld.
- On sample 3, it is observed that non uniformity along the bead with pin holes defective.

**If instructor provides actual welded samples, to trainees it may be cleaned the weld joints with wire brush used be free from dirt, dust, slag which may affect the quality of appearances for visual examination.**

---

### Task 2: Inspection of weld sample fillet joints

#### Job Sequence

- Study the given weld sample for fillet joint for inspecting the type of defects.
- Observe the fillet weld joint and prepare ably cleaned lee force visual inspection using with wire brush.
- Ensure that the cleaned surface is free from dirt, dust, slag etc. which may affect the quality of appearance for visual examination.
- Record the name of the defects each mentioned is welded sample fillet joint.
- Record the observations in the register with details.

---

### Task 3: Inspection of weld sample butt joint

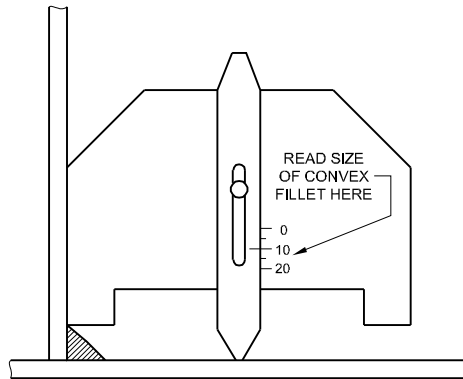
#### Job Sequence

- Study the given weld sample for butt joint for inspecting the type of defects.
  - Observe the butt joint and prepare ably cleaned lee force visual inspection using with wire brush.
  - Ensure that the cleaned surface is free from dirt, dust, slag etc., which may affect the quality of appearance for visual examination.
  - Record the name of the defects each mentioned in welded sample butt joint.
  - Record the observations in the register with details.
-

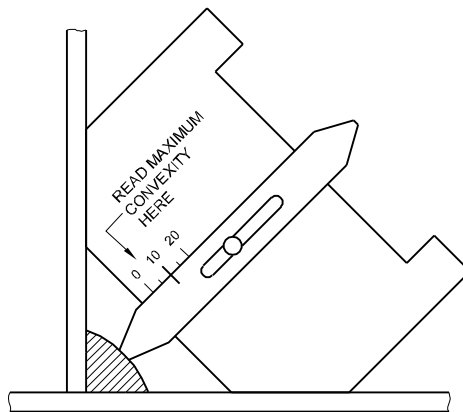
Inspection of welds using weld gauges (I&T-01)

**Objectives:** At the end of this exercise you shall be able to

- use weld gauges for inspection of welds
- check the concave / convex of fillet weld profile
- check the leg length / weld thickness.



TO MEASURE THE SIZE OF A FILLET WELD



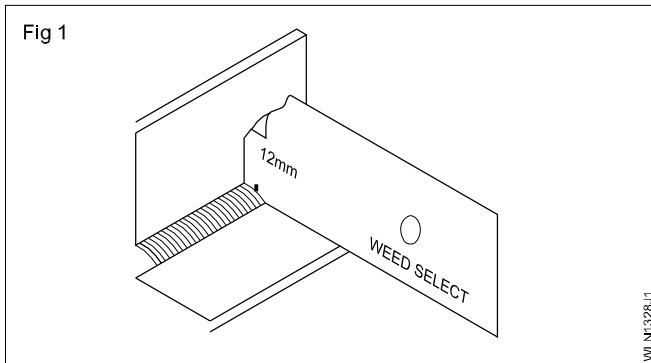
TO CHECK THE MAXIMUM PERMISSIBLE CONVEXITY

**Note:** Instructor should provide welded samples to inspect the welding using the weld fillet gauges.

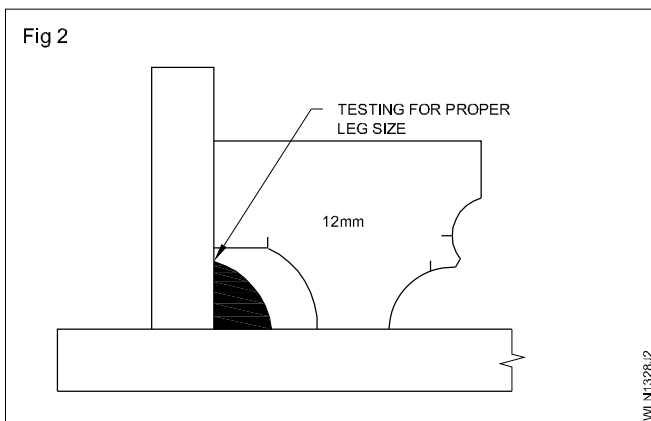
1	-	-	-	-	-	1.3.28
NO.OFF	STOCK SIZE	SEMI-PRODUCT	MATERIAL	PROJECT NO.	PART NO.	EX. NO.
SCALE NTS	<b>INSPECTION OF WELDS USING WELD GAUGES (I&amp;T-01)</b>				TOLERANCE ±1	TIME 1 Hrs
					CODE NO. WLN1328E1	

## Task 1: Inspection of welds using weld gauges

- Study the given weld sample for inspecting using weld gauge.
- Clean the weld surface using wire brush and to be free from dirt, dust, and slag.
- Select the required size of weld gauge leaf (12mm) and place it against the weld as shown in (Fig 1).

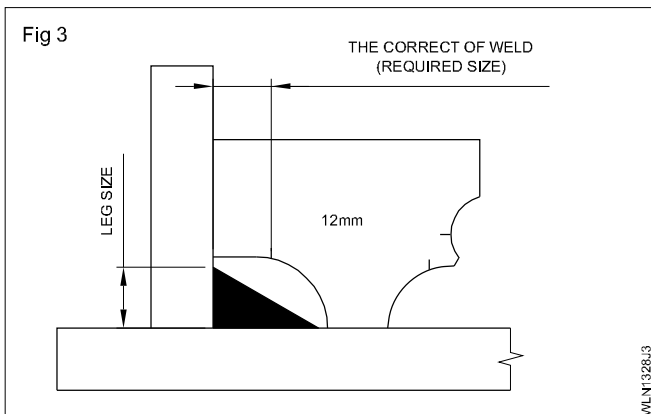


- Slide the gauge, so that the top end touches the vertical plate.
- The end of the gauge should exactly touch the top edge of line weld is the correct size of the weld (Fig 2).

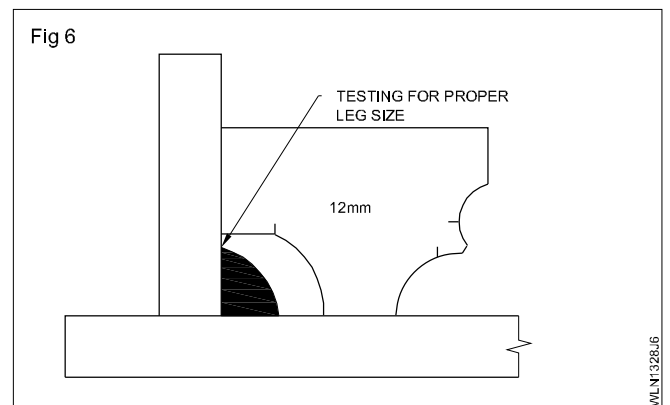
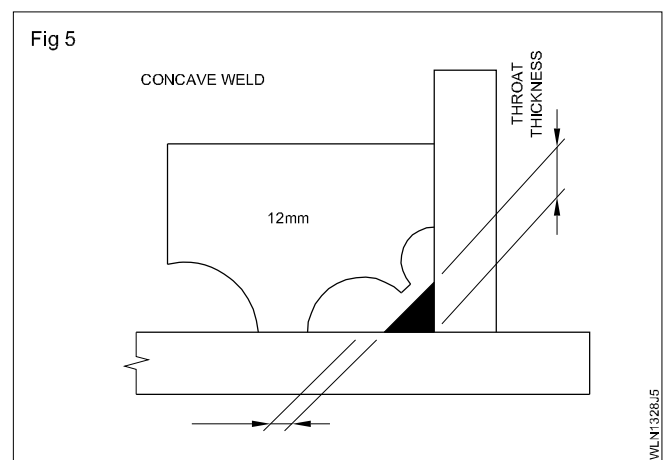
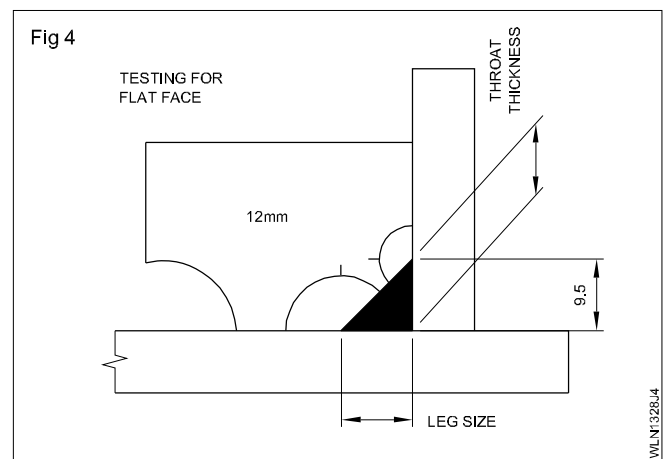


If there is a space between gauge and the toe of the weld then it is under sized weld.

- If the toe of weld is move, the gauge has more space to accommodate as shown in Fig 3. The vertical line on gauge shows that the bottom toe is larger than the required size (correct size).

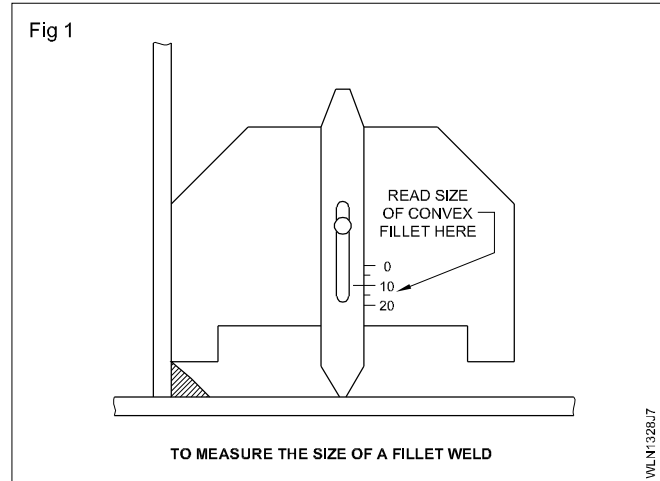


If the weld size 12 mm is satisfied with the gauge, then it should be checked for the corrections throat thickness (Fig 4). This is done by checking for concave or convex face of weld bead. Correct face of weld coincides with gauge as in Fig 4. If there is a gap at the measuring force of gauge, then the weld may be concave as shown in Fig 5. This means the weld is not having the correct throat thickness or it is under size then the required size. Hence it is "not acceptable". If it convex, but the less then the required leg size is also, a "not acceptable" weld. Fig 6 show that there is a clearance between the weld toe and gauge measuring face.



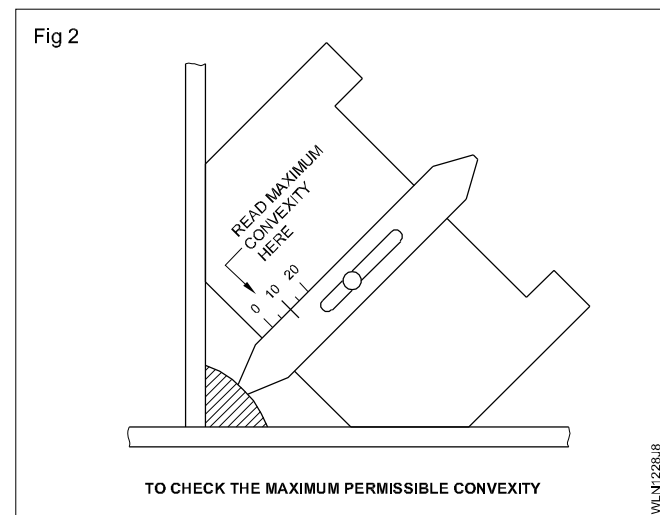
## Task 2: To measure the leg size of fillet weld using AWS-Standard fillet gauge

- Place the gauge against the toe of the weld as shown in Fig 1. Slide the pointer to rest over the bottom plate of the job. The leg size of fillet is observed on the graduated scale of gauge. This is the leg size of fillet weld.



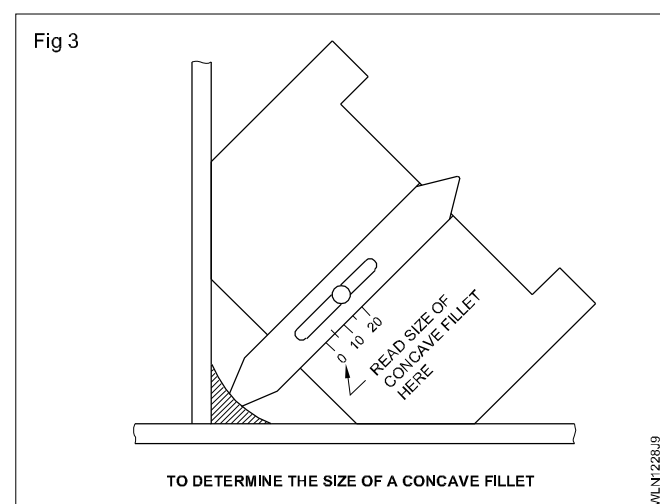
## Task 3 : To measure the acceptable convexity of fillet weld

- Place the gauge against the vertical plate of fillet weld joint (as shown in Fig 2).
- Ensure 45° sides are in contact with both vertical and bottom plate of fillet weld joint.
- Slide the pointer to rest over the weld face.
- Observe the measurement on graduated scale on coincidence with slide mark.
- Record the measurement to find out the acceptable size of weld reinforcement.



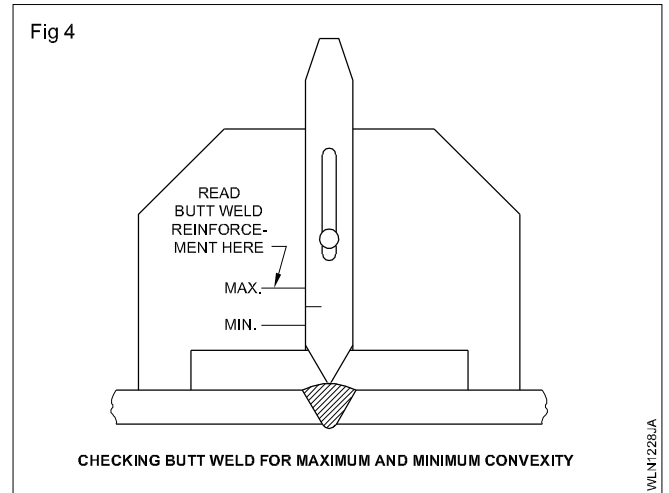
## Task 4 : To measure the acceptable concavity of fillet weld

- Place the gauge against the vertical plate of fillet weld joint (as shown in the Fig 3).
- Ensure the 45° sides are in contact with vertical and horizontal plate of fillet weld joint.
- Slide the pointer to rest over the concave weld face.
- Observe the measurement on graduations and coincidence with slide mark.
- Record the measurement to find out the acceptable size of weld reinforcement.



**Task 5 : To measure reinforcement on a butt welded joint**

- Place the gauge so that pointer may be seated over the weld seam as in Fig 4.
- Observe the measurement, and record accordingly at concave portion or convex portion of the weld by placing it in position.

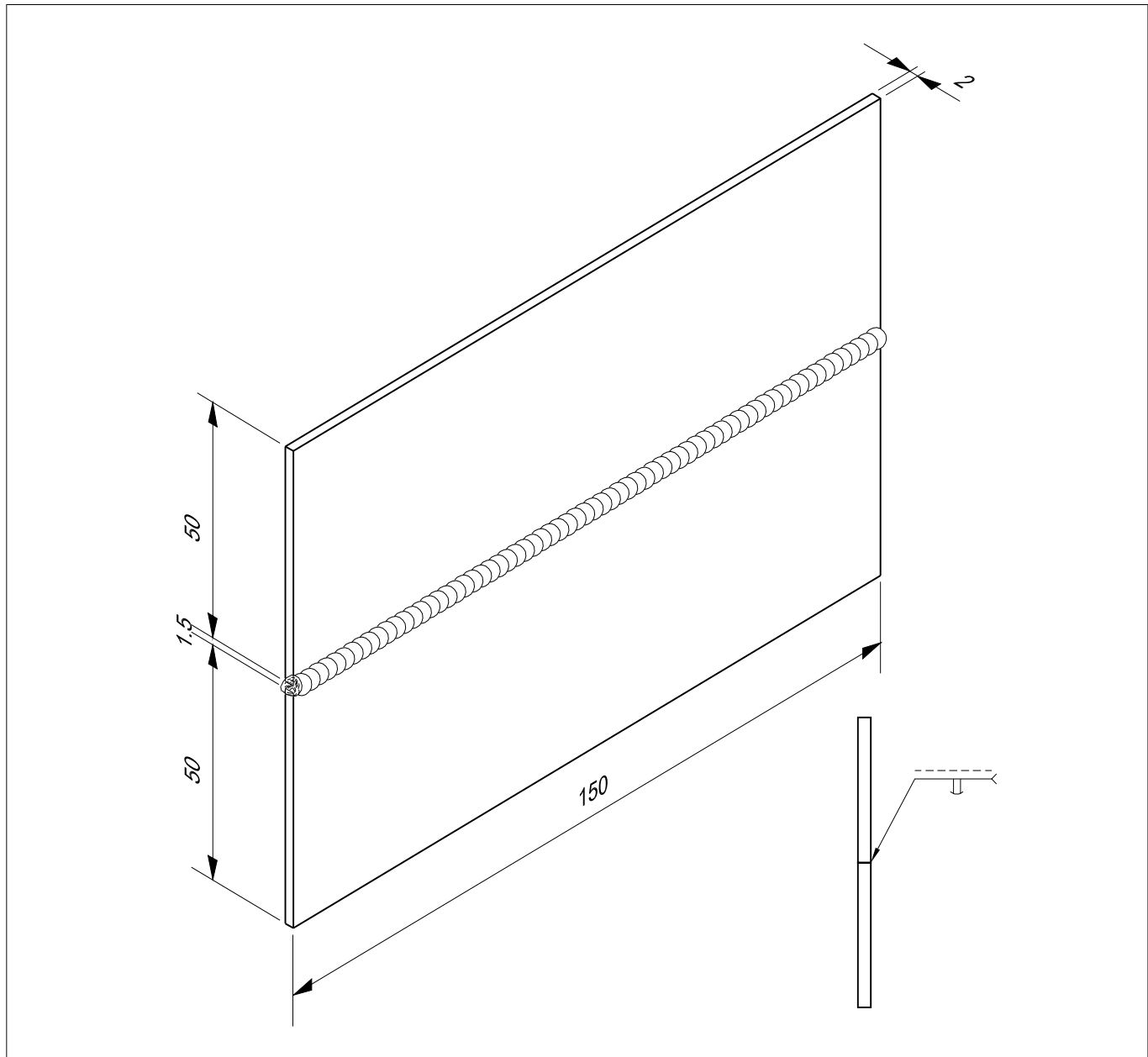


-----

Square butt joint on MS sheet 2mm thick in horizontal position (2G)-(OAW-08)

Objectives: At the end of this exercise you shall be able to

- set and tack the job pieces to form a square butt joint with proper root gap
- fix the job in the positioner in horizontal position
- weld square butt joint by proper manipulation of the blowpipe and filler rod using leftward technique
- ensure good root penetration weld reinforcement and bead profile
- clean and inspect the welded joint for weld defects.



2	ISST 50 x 2 - 150	-	Fe 310 - W	-	-	1.3.29
NO.OFF	STOCK SIZE	SEMI-PRODUCT	MATERIAL	PROJECT NO.	PART NO.	EX. NO.
SCALE NTS	<b>SQUARE BUTT JOINT ON M.S SHEET 2mm THICK IN HORIZONTAL POSITION (2G)-(OAW-08)</b>				TOLERANCE ±0.5	TIME 10 Hrs
					CODE NO. WLN1329E1	



## Job Sequence

- Prepare the job pieces as per drawing.
- Clean the edges and surfaces of the metal pieces.
- Set the job pieces as square butt joint with a root gap of 1.5 mm.
- Select the nozzle No. 5 and C.C.MS. filler rod dia. 1.6 mm.
- Set a gas pressure of 0.15 kg/cm<sup>2</sup>.
- Follow necessary safety precautions.
- Tack weld the sheets and check for uniform root gap and alignment.
- Weld the joint with a single run in horizontal position.
- Clean the welded area and inspect the weld for defects.

## Skill Sequence

### Weld square butt joint 2mm horizontal position (2G)

**Objective:** This shall help you to

- **prepare and weld square butt joint MS plate 2mm in horizontal position.**

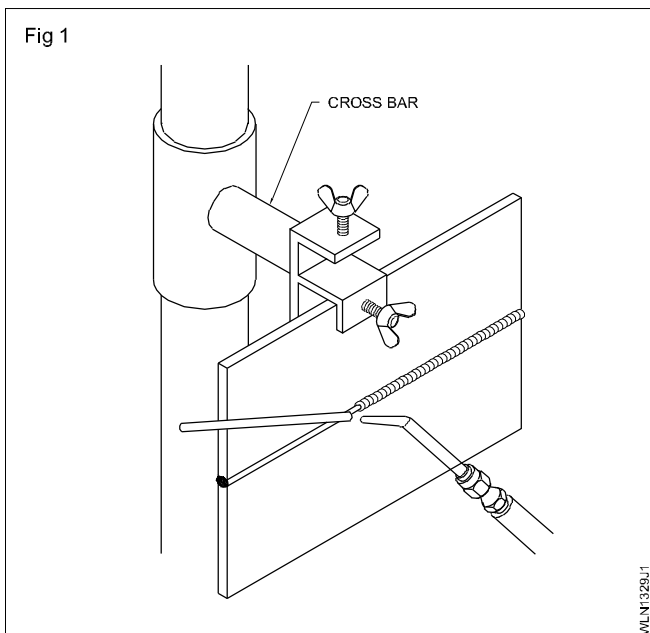
Position the crossbar of the positioner to the eye level. (Fig 1)

Adjust the pressure of oxygen and that of acetylene at 0.15 kg/cm<sup>2</sup>.

Set a soft neutral flame.

Tack-weld the job at both ends and at the center with a root gap of 2.5 mm.

Fix the job on the crossbar of the positioner in horizontal position. (Fig 1)



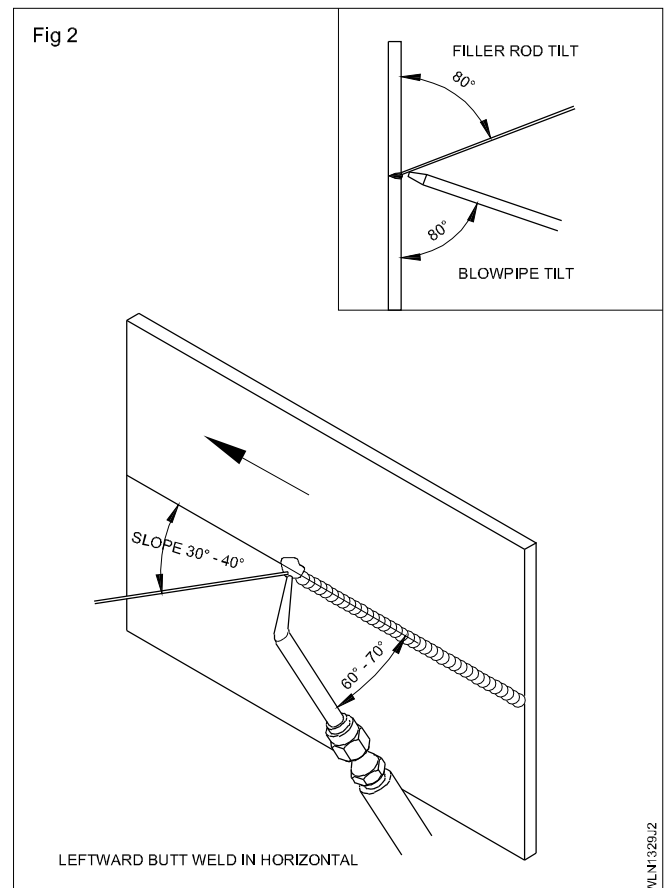
**Ensure the job is in horizontal position at a convenient height.**

Hold the blowpipe at 60° to 70° and the filler rod at 30° to 40° to the line of weld. Deposit the bead from the right end of the joint by giving a circular motion to the blowpipe and proceed towards the left end.

**Ensure both edges melt equally and up to the root of the joint.**

Check the weldment for correct profile with complete penetration.

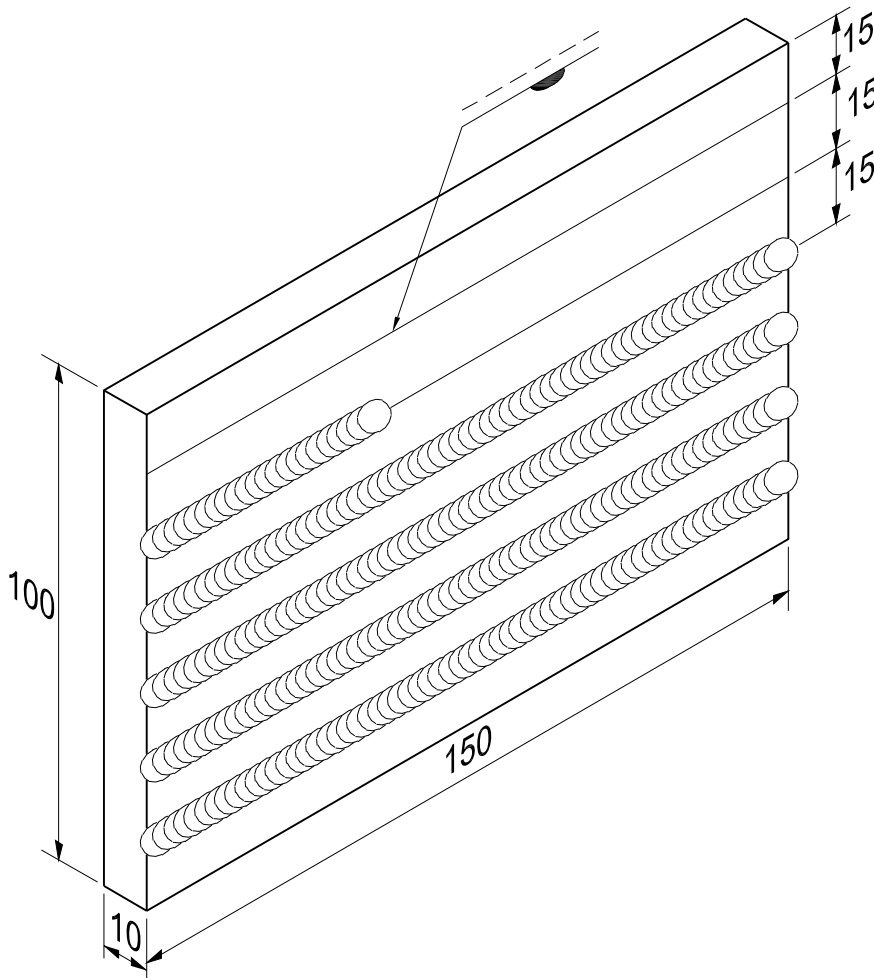
Proper angle between the blow pipe, filler rod and the sheet surface is to be maintained (Fig 2). The filler rod is added when the inner cone of the flame reaches the top edge of the joint. This will help in avoiding the excessive melting of the bottom edge of the joint and will avoid sagging of weld metal.

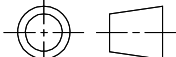


**Straight line beads and multi layer practice on M.S. plate 10mm thick in horizontal position (SMAW-08)**

**Objectives:** At the end of this exercise you shall be able to

- select the electrode, current, polarity and arc length suitable for welding in horizontal position
- deposit uniform straight line beads in horizontal position
- control the molten metal and slag by the manipulation of the electrode angle
- prevent sagging of weld metal.



1	100 ISF x 10 - 150	-	Fe 310 - W	-	-	1.3.30
NO.OFF	STOCK SIZE	SEMI-PRODUCT	MATERIAL	PROJECT NO.	PART NO.	EX. NO.
SCALE NTS	<b>STRAIGHT LINE BEADS ON M.S PLATE 10mm THICK AND MULTIPASS PRACTICE IN HORIZONTAL POSITION (SMAW-08)</b>				TOLERANCE ±1	TIME 6 Hrs
					CODE NO. WLN1330E1	

# Job Sequence

## Preparation

- Mark and cut the plate as per drawing. Clean the surface and file the edges before punching the lines.
- Scribe lines and make punch marks as per job drawing.
- Select a 3.15mm electrode and set 110 amps and use DCEN. Set the job in a horizontal position.
- To avoid sagging molten metal, use a short etc.
- Convex bead will trap slag.

- Start at left hand side of the plate hold the electrode pointing upward at angle of 70° to 80° to the surface of base metal. Use a travel angle 70° to 80° to weld direction.
- Remove the slag with a chipping hammer and clean the bead with a wire brush.

## Inspection of bead

- Inspect the bead weld for surface defects like undercut, slag inclusions, overlap etc.

# Skill Sequence

## Weld straight line bead on MS plate 10mm in horizontal position

**Objective:** This shall help you to

- **prepare and weld straight line bead on MS plate 10mm in horizontal position.**

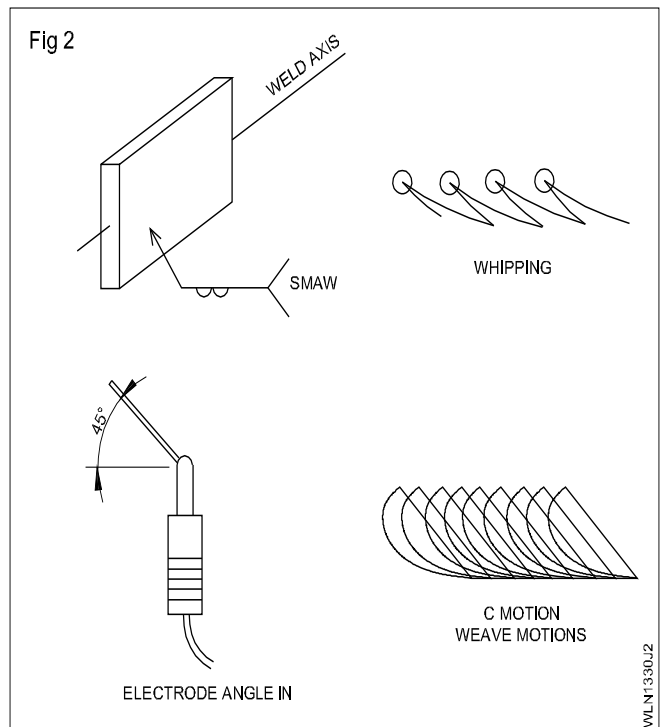
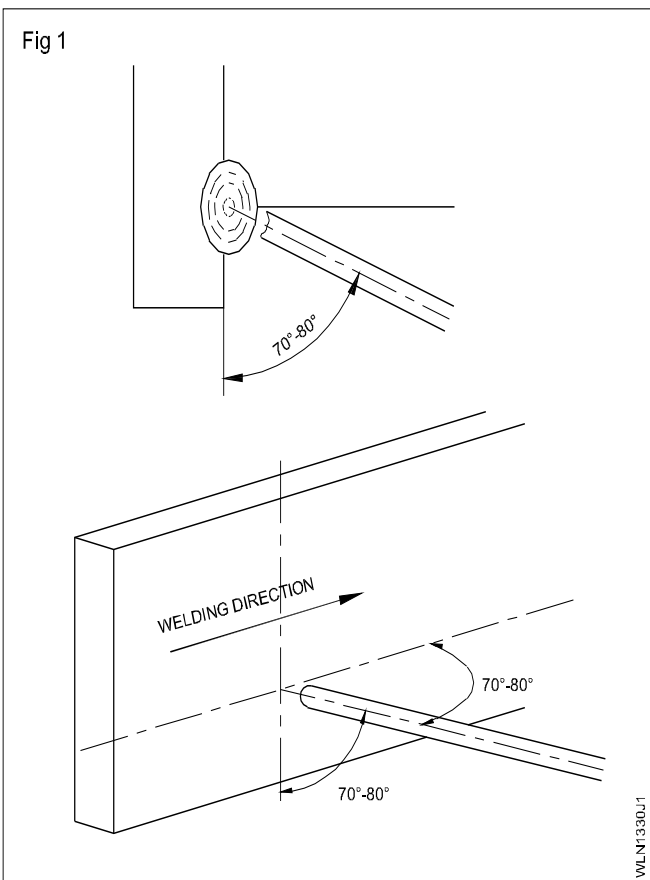
Making a bead on plate weld in the horizontal position is very much like making it in a flat position.

But the angle of electrode should be held at an angle to the surface and inclined to the line of travelling as shown in the Fig 1.

Reduce the current to get faster cooling. This helps to avoid overhanging of weld puddle at the bottom side of the plate.

Use a faster travel speed and maintain weld puddle size not larger than the coating diameter of the electrode.

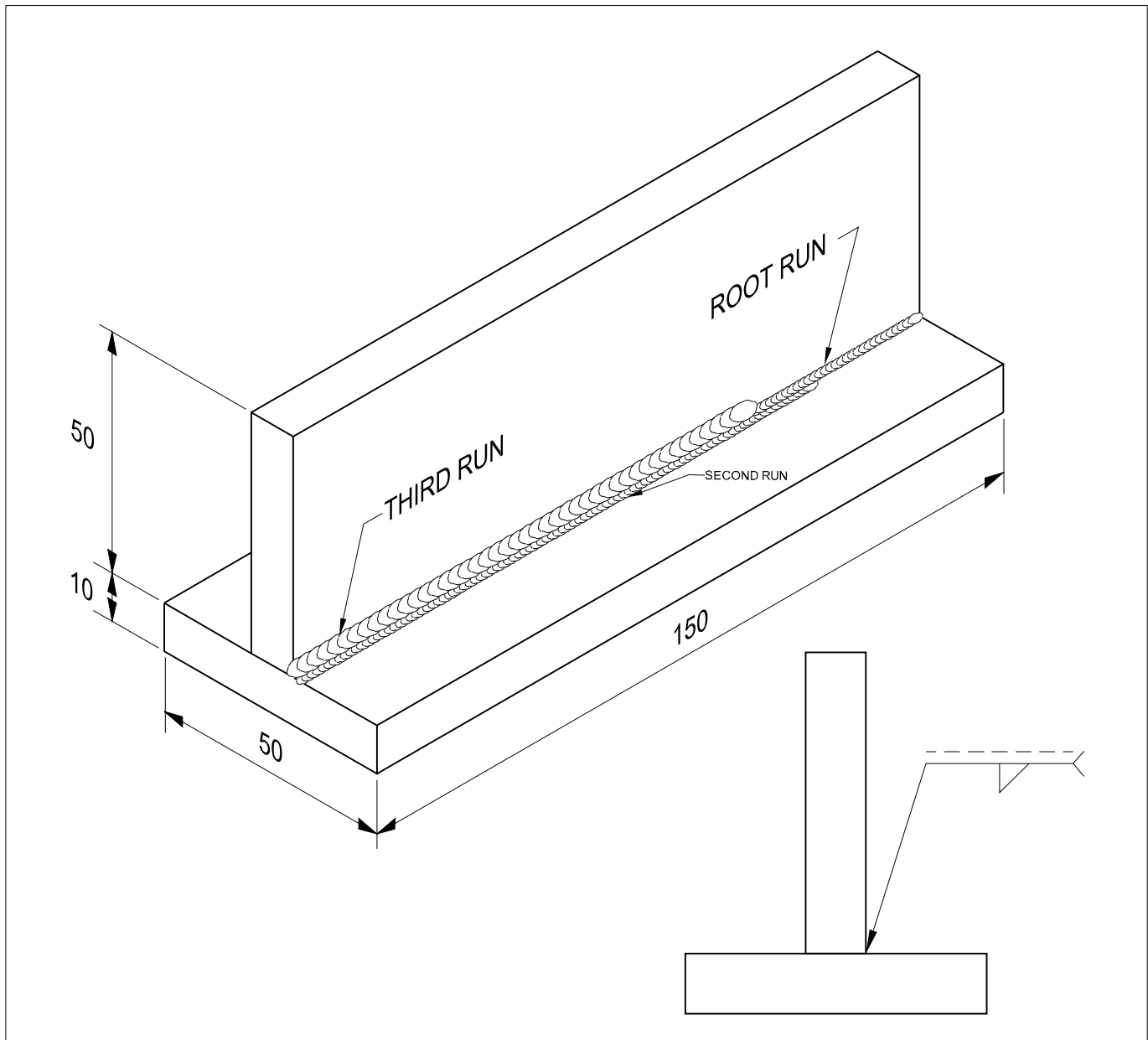
Move the electrode to the right with a slight whipping motion or a "C" motion as shown in Fig 2. This helps to cool the puddle slightly, solidify faster and avoid sagging of bead. While using "C" motion pause at the upper left of the "C".  
Fig 2



**Fillet - 'T' joint on MS plate 10mm thick in horizontal position (2F)-(SMAW-09)**

**Objectives:** At the end of this exercise you shall be able to

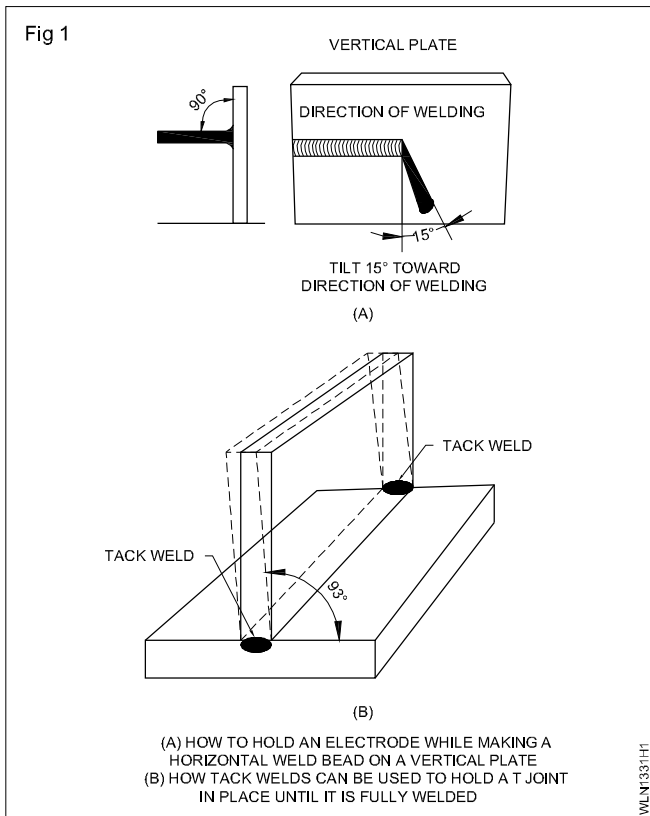
- select electrode, current, polarity and arc length
- use distortion control and arc blow control methods
- weld the 'T' joint with a short arc and uniform travel speed
- inspect the weldments for external defects.



2	50 ISF x 10 - 150		Fe 310 - W			1.3.31
NO.OFF	STOCK SIZE	SEMI-PRODUCT	MATERIAL	PROJECT NO.	PART NO.	EX. NO.
SCALE NTS	<b>FILLET 'T'- JOINT ON M.S PLATE 10mm THICK IN HORIZONTAL POSITION (2F)-(SMAW-09)</b>				TOLERANCE ±1	TIME 9 Hrs
					CODE NO. WLN1331E1	

## Job Sequence

- Prepare and clean the plates as given in Ex.No.E-8/3.04.



- Set the Tee joint as per drawing and tack weld (Fig 1)
- Fix the joint in horizontal position.
- If DC machine is used, connect the electrode to the negative and use short arc to control arc blow.
- To avoid distortion due to contraction preset the plates such a way that the angle of the tack welded joint is increased to 92° to 93° on the welding side.
- Deposit the root run without weaving.
- Hold the electrode at the center of the joint and start from leftward and use proper technique to avoid excessive metal deposition at the bottom of the plate.
- Deslag and clean the root run.
- Deposit the second and third run using stringer bead technique covering the previously laid bead partially and the plate surface.
- Ensure to fill the crater and to clean the bead.
- Check for the size of fillet, bead profile, weld defects and rectify them.

## Skill Sequence

### 'T' joint weld on MS plate 10mm in horizontal position

**Objective:** This shall help you to

- set and weld 'T' joint on MS plate 10mm thick in horizontal position.

Fix the joint in a horizontal position. For this the bottom plate should be kept parallel to the ground and the other plate perpendicular. Fig 1.

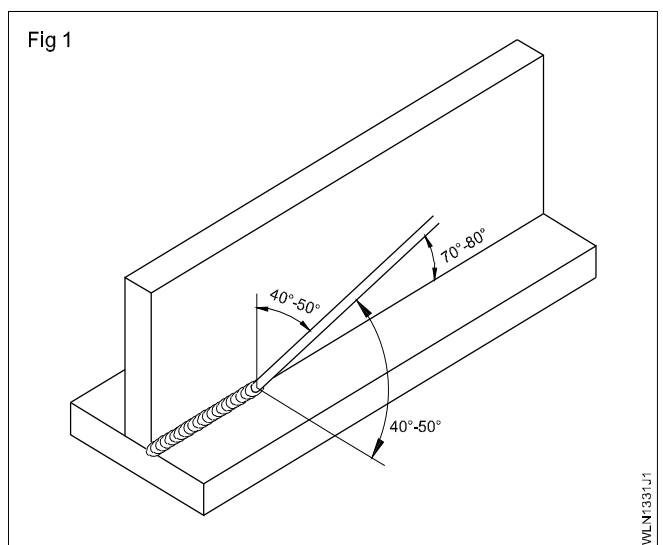
**Welding Tee joint (fillet) in horizontal position:** Deposit root run with 3.15 mm dia. electrode and 110 amps welding current, maintaining the electrode angle 70° to 80° to the line of weld and 40° to 50° between the vertical plate and electrode (as in Fig 1).

Maintain a short arc to get uniform fusion and proper root penetration.

Deslag and clean the root bead thoroughly. Use safety goggles while deslagging to protect the eyes from flying slag particles.

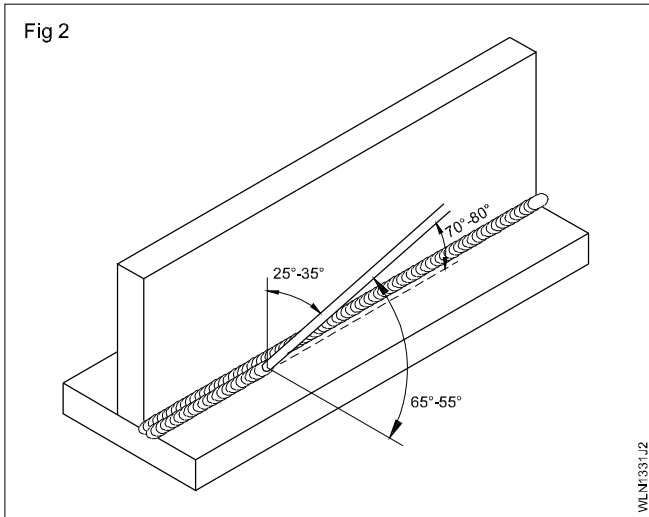
Deposit second run with a 4 mm electrode and 160 amps welding current, the angle of electrode to the bottom plate to be 55° - 65° and 25° - 35° to the vertical plate and 70° to 80° to the line of weld. (As in Fig 2.)

This second run has to be deposited partly covering the root run and partly on the bottom plate. Fig 4



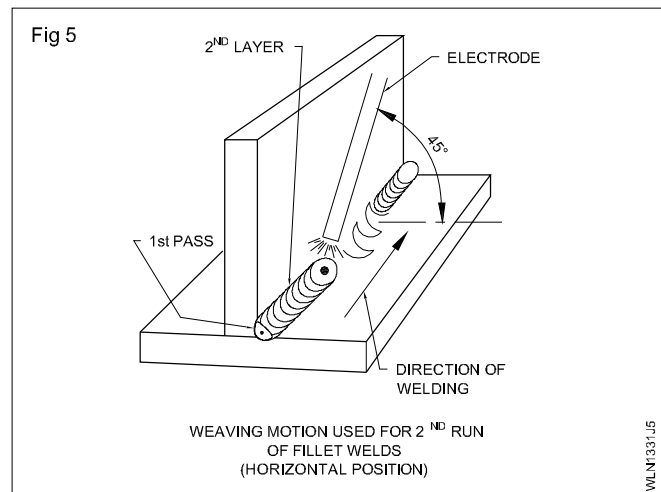
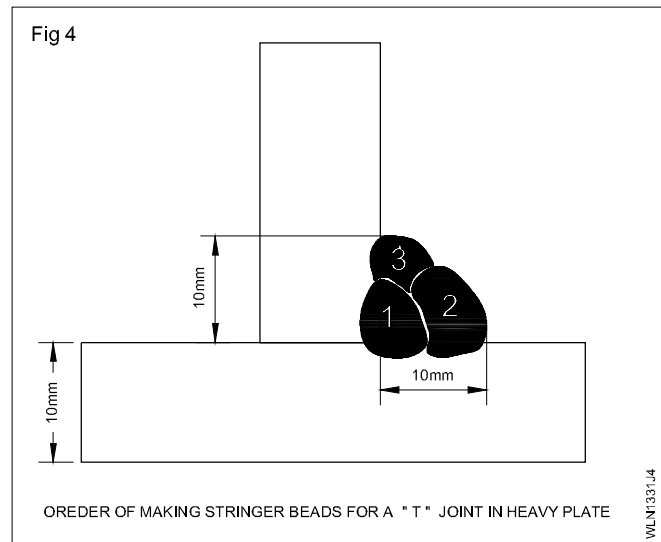
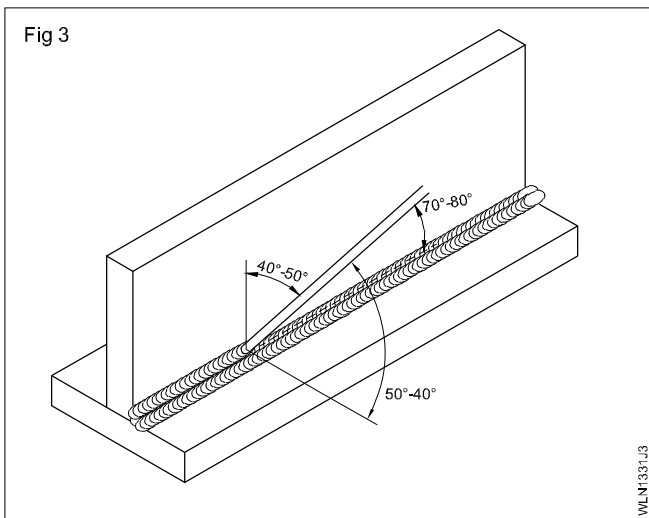
Give a steady movement to the electrode using a short arc.

Deslag and clean the weld bead.



Deposit the third and final run with a 4 mm dia. Electrode and 160 amps welding current. Angle of the electrode to the line of weld is 70° to 80° and 40° - 50° on both plates. (Fig 3) The third run has to be deposited in such a way that the bead covers partly the root run and the second run and partly the vertical plate (Fig 4). Also there should not be a valley at the bottom toe line of the third run in order to maintain necessary throat thickness. If two pass technique is adopted second run should be done in a weaving motion. (Fig 5)

Deslag and clean the weld bead.



**Avoid over-deposition and side undercut by using a proper angle and travel speed of the electrode.**

Inspection of T joint

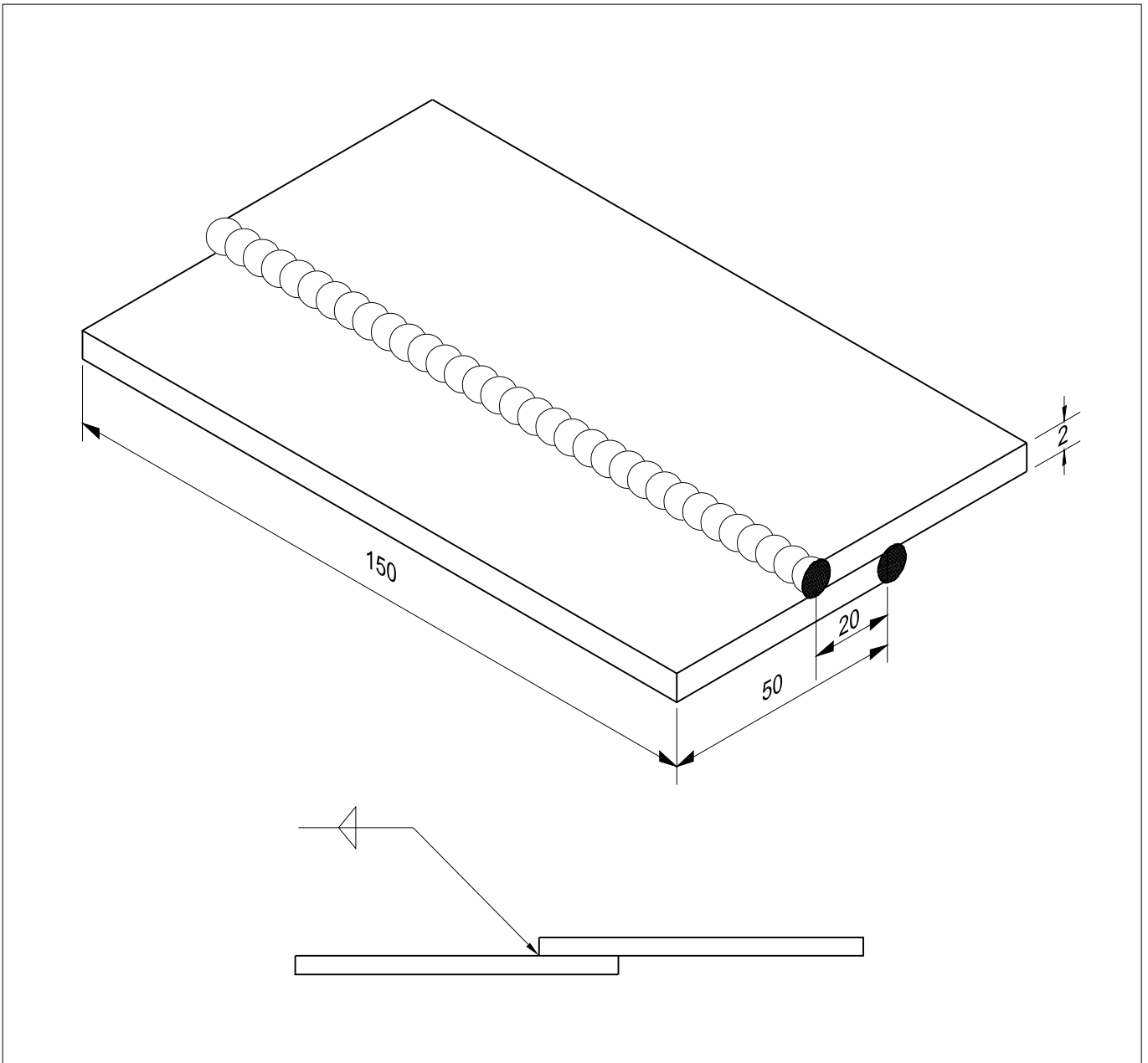
Inspect the fillet weld for equal leg length and correct size.

Inspect to ensure the fillet weld is free from undercut and excessive lapping on bottom plate.

**Fillet - lap joint on MS sheet 2mm thick in horizontal position (2F)-(OAW-09)**

**Objectives:** At the end of this exercise you shall be able to

- set and tack the job to form a lap fillet joint with recommended overlap
- weld lap fillet joint using correct size filler rod and nozzle in horizontal position
- clean and inspect the weldments of the lap fillet for weld defects.



2	ISST 50 x 2 - 150	-	Fe 310 - W	-	-	1.3.32
NO.OFF	STOCK SIZE	SEMI-PRODUCT	MATERIAL	PROJECT NO.	PART NO.	EX. NO.
<p><b>FILLET - LAP JOINT ON M.S.SHEET 2mm THICK IN HORIZONTAL POSITION (2F)-(OAW-09)</b></p>					TOLERANCE ±1	TIME 12Hrs
					CODE NO. WLN1332E1	
<p>SCALE NTS</p>						

## Job Sequence

- Prepare the job pieces as per drawing.
- Clean the edges and surfaces of the metal pieces.
- Set the job pieces as lap joint.
- Select the nozzle No. 5 and C.C.M.S. filler rod 3mm $\varnothing$ .
- Set a gas pressure of 0.15 kg/m<sup>2</sup>.
- Follow necessary safety precautions.
- Tack weld the sheets and check for alignment
- Weld the joint with a single run in horizontal position.
- Clean the welded area and inspect the weld for defects.

## Skill Sequence

### Lap joint on MS sheet 2.00mm in horizontal position (2F)

---

**Objective:** This shall help you to

- **prepare and weld lap joint on MS sheet 2.00mm in horizontal position.**
- 

- Position the cross bar of the positioner to the eye level.
- Adjust the pressure of oxygen and that of acetylene at 0.15 kg/cm<sup>2</sup>.
- Set and tack the job pieces in correct alignment with proper overlapping of pieces.
- Place the tack welds at correct locations.
- Fix the job on the cross bar of the positioner in horizontal position.
- Hold the blowpipe at 60 to 70° and the filler rod at 30 to 40° to the line of weld. Deposit the bead from the right end of the joint by giving a circular motion to the blowpipe and proceed towards the left end.
- Maintain correct travel speed, manipulation of blowpipe and filler rod to produce uniform weld bead.

#### **Clean the weldment and inspect for:**

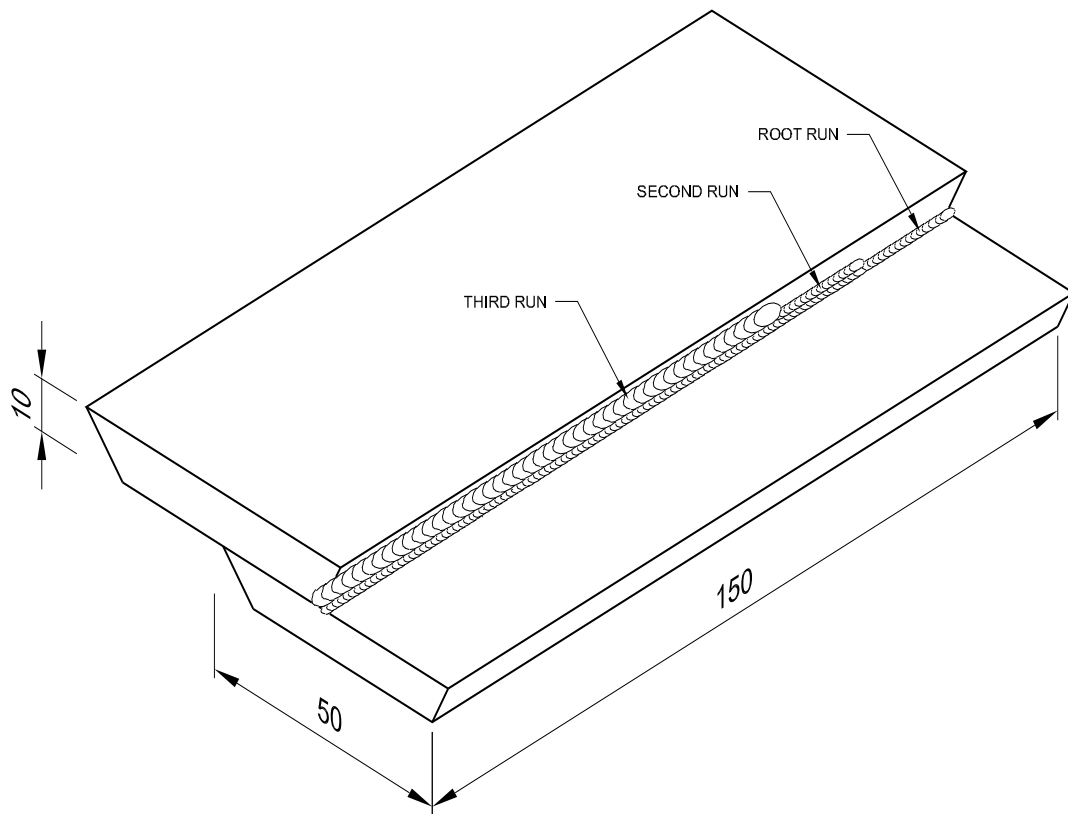
- Uniform weld size and shape of whole length (reinforcement and contour) of the joint.
- Equal leg length.
- No undercut at the toe of weld.
- Smooth ripple appearance.
- Proper crater filling.



**Fillet lap joint on MS plate 10mm thick in horizontal position (2F)-(SMAW-10)**

**Objectives:** At the end of this exercise you shall be able to

- select electrode, current, polarity and arc length
- use distortion control and arc blow control methods
- weld the lap joint with a short arc and uniform travel speed
- inspect the weldments for external defects.



2	50 ISF x 30 - 150	-	Fe 310 - W	-	-	1.3.33
NO.OFF	STOCK SIZE	SEMI-PRODUCT	MATERIAL	PROJECT NO.	PART NO.	EX. NO.
SCALE NTS	<b>FILLET LAP JOINT ON M.S PLATE 10mm THICK HORIZONTAL POSITION (2F)-(SMAW-10)</b>				TOLERANCE ±1	TIME 13 Hrs
					CODE NO. WLN1333E1	

## Job Sequence

- Prepare and clean the plates as per given dimensions.
- Set the Lap joint as per drawing and tack weld.
- Fix the joint in horizontal position.
- If DC machine is used, connect the electrode to the negative and use short arc to control arc blow.
- To avoid distortion due to contraction preset the plates such a way that the angle of the tack welded joint is decreased to 87° on the Back side.
- Deposit the root run without weaving.
- Hold the electrode at the center of the joint and start from leftward and use proper technique to avoid excessive metal deposition at the bottom of the plate.
- Deslag and clean the root run.
- Deposit the second and third run using stringer bead technique covering the previously laid bead partially and the plate surface.
- Ensure to fill the crater and to clean the bead.
- Check for the size of fillet, bead profile, weld defects and rectify them.

## Skill Sequence

### Fillet weld lap joint MS plate 10mm horizontal position (2F)

**Objective:** This shall help you to

- **prepare and weld lap joint on MS plate 10mm in horizontal position.**

Fix the joint in a horizontal position. For this the bottom plate should be kept parallel to the ground and the other plate perpendicular.

**Welding Lap joint (fillet) in horizontal position:** Deposit root run with 3.15 mm dia. electrode and 110 amps welding current, maintaining the electrode angle 70° to 80° to the line of weld and 40° to 50° between the vertical plate and electrode.

Deslag and clean the root bead thoroughly. Use safety goggles while deslagging to protect the eyes from flying slag particles.

Deposit second run with a 4mm electrode and 160 amps welding current, the angle of electrode to the bottom plate to be 55° - 65° and 25° - 35° to the vertical plate and 70° to 80° to the line of weld.

This second run has to be deposited partly covering the root run and partly on the bottom plate.

Give a steady movement to the electrode using a short arc.

Deslag and clean the weld bead.

Deposit the third and final run with a 4 mm dia. electrode and 160 amps welding current. Angle of the electrode to the line of weld is 70° to 80° and 40° - 50° on both plates. The third run has to be deposited in such a way that the bead covers partly the root run and the second run and partly the vertical plate. Also there should not be a valley at the bottom toe line of the third run in order to maintain necessary throat thickness. If two pass technique is adopted second run should be done in a weaving motion. Deslag and clean the weld bead.

**Avoid over-deposition and side undercut by using a proper angle and travel speed of the electrode.**

Inspection of Tee joint

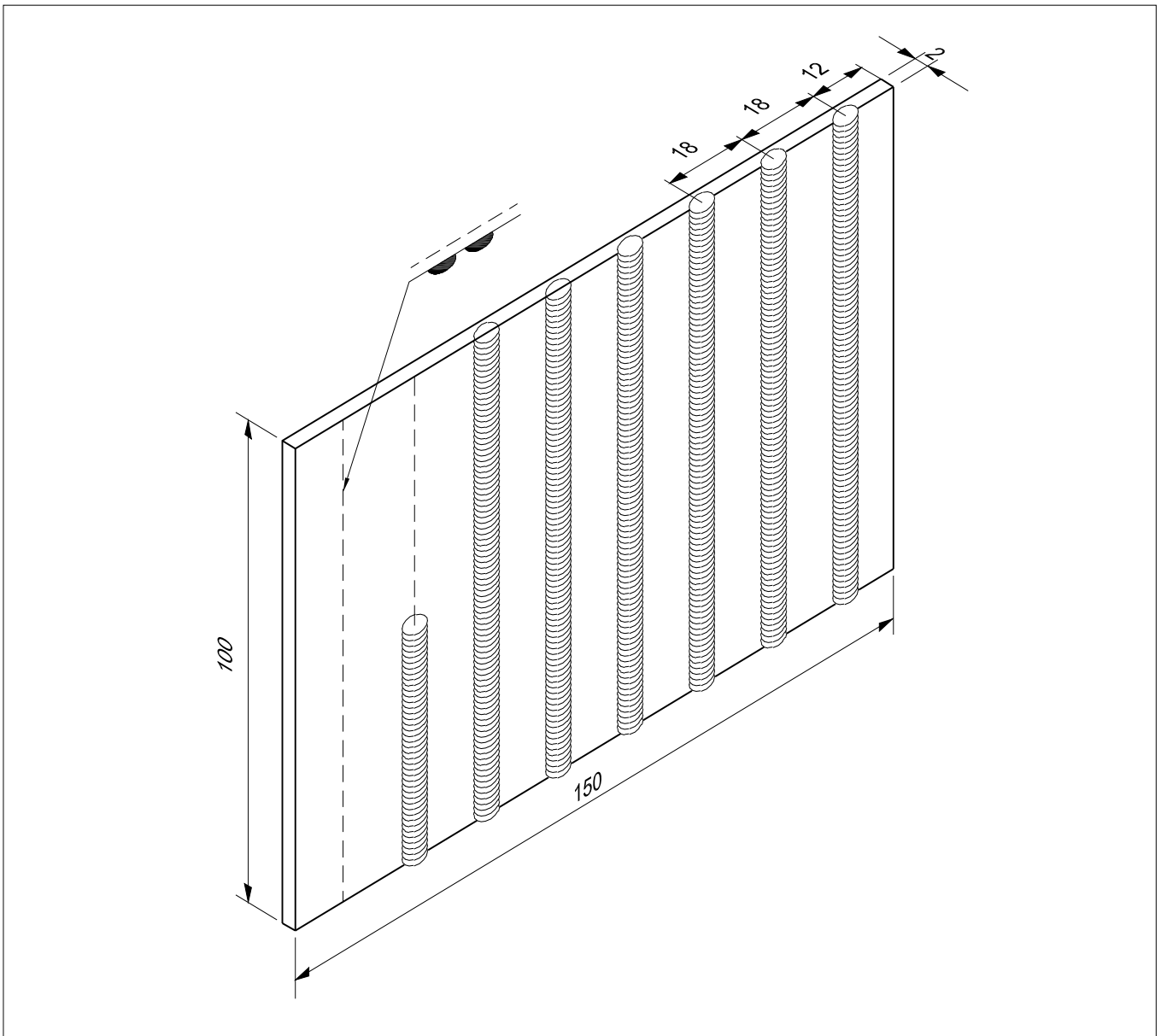
Inspect the fillet weld for equal leg length and correct size.

Inspect to ensure the fillet weld is free from undercut and excessive lapping on bottom plate.

**Fusion run with filler rod in vertical position on 2mm thick MS sheet (OAW-10)**

**Objectives:** At the end of this exercise you shall be able to

- prepare the job as per drawing
- fix the job in vertical position in the weld positioner
- select the nozzle and filler rod size and the gas pressure
- manipulate the blowpipe and filler rod maintaining proper angle
- deposit bead in vertical position in upward direction along a straight line
- clean and inspect the bead visually and identify the defects.



1	ISST 100 x 2 - 150	-	Fe 310 - W	-	-	1.3.34
NO.OFF	STOCK SIZE	SEMI-PRODUCT	MATERIAL	PROJECT NO.	PART NO.	EX. NO.
SCALE NTS		<b>FUSION RUN WITH FILLER ROD IN VERTICAL POSITION ON 2mm THICK M.S SHEET (OAW-10)</b>			TOLERANCE ±1	TIME 8 Hrs
					CODE NO. WLN1334E1	

## Job Sequence

- Prepare the sheet as per drawing and scribe straight lines and punch mark them as per the sketch.
- Clean the surface of the sheet.
- Fix the marked sheet on the weld positioner or vertical welding jig in vertical position at a convenient height.
- Select No. 5 size nozzle and fix it to the blow pipe.
- Select 1.5mm dia. CCMS rod and set 0.15 kg/sq.cm pressure for the gases.
- Follow necessary safety precautions.
- Light the blowpipe and set neutral flame.
- Hold the blow pipe at 75° and the filler rod at 30 - 40° to the line of weld. The angle between the blow pipe nozzle and filler rod and the sheet surfaces should be at 90°.
- Deposit the weld bead starting from the bottom most point of a punched line and moving upwards along the line.
- Ensure the melting of the base metal and the filler rod are kept as minimum as possible.
- Maintain proper angles for the blow pipe and filler rod.
- Move the blow pipe and filler rod without any side to side movements along the marked line at a uniform speed in upward direction.
- Do not allow the inner cone of the flame to come in contact with the molten metal (puddle) to avoid back fire.
- Complete depositing the weld bead up to the top end of the line and ensure to fill the crater.
- Ensure to avoid undercut defect by proper manipulation of the blow pipe and the filler rod.
- Clean the bead and visually inspect for any surface / external defect.
- Repeat the exercise on the other punch marked lines for more practice.

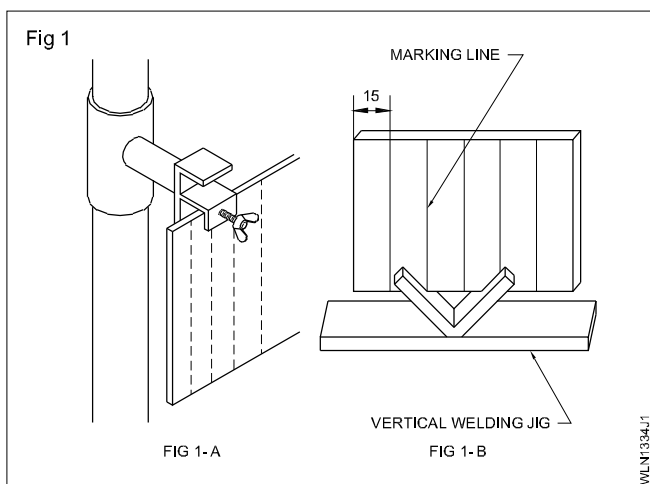
## Skill Sequence

### Fusion run with filler rod, 2mm MS sheet in vertical position

**Objective:** This shall help you to

- prepare and carry out fusion run with filler rod in 2mm MS sheet in vertical position.

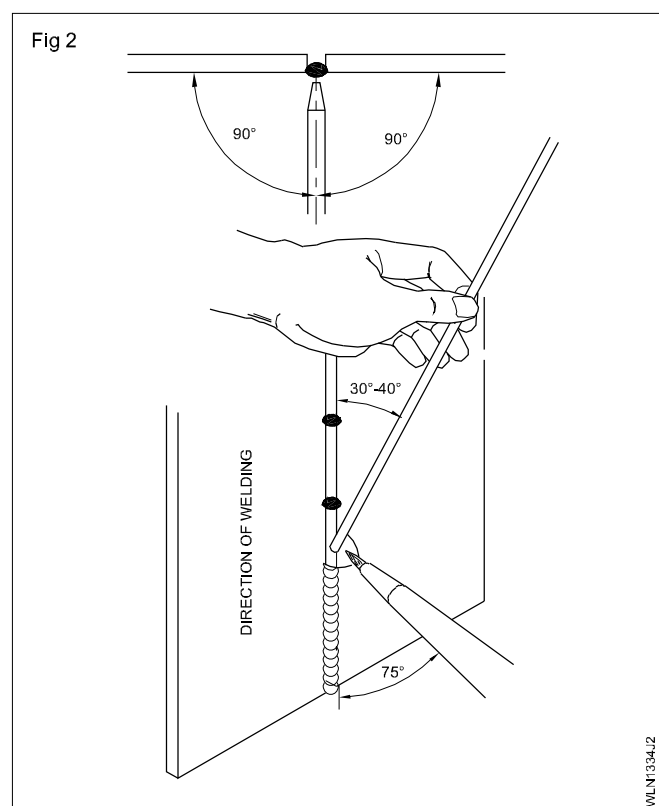
**Job setting:** Fix the job in vertical position. (Figs 1A or B) at a level from the ground based on your height.



Fix nozzle No. 5 and select a CCMS rod 1.5mmø.

**Welding technique:** Deposit the weld in vertical upward position.

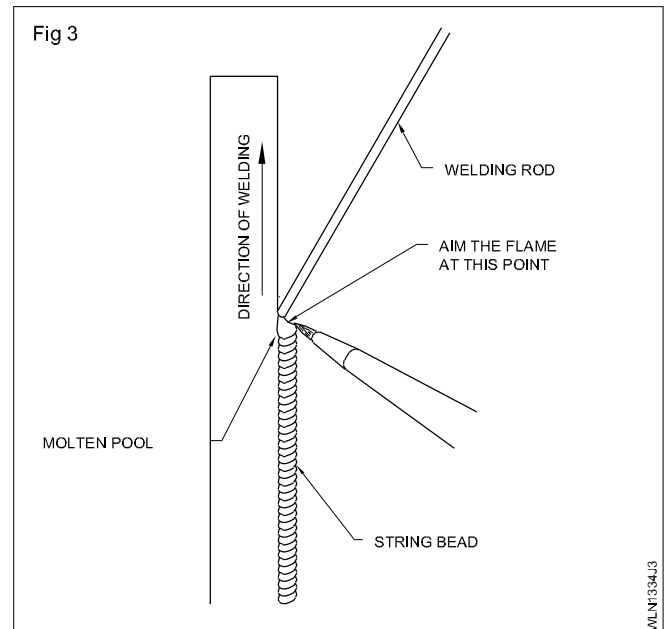
Maintain the angle of the blowpipe at 75° and the filler rod at 30° - 40°. (Fig 2)



Control the molten pool without giving any circular motion to the blowpipe. (Fig 3)

Take due care that the weight of the blow pipe and hoses do not pull your hand downwards while the deposition of weld metal progresses upwards.

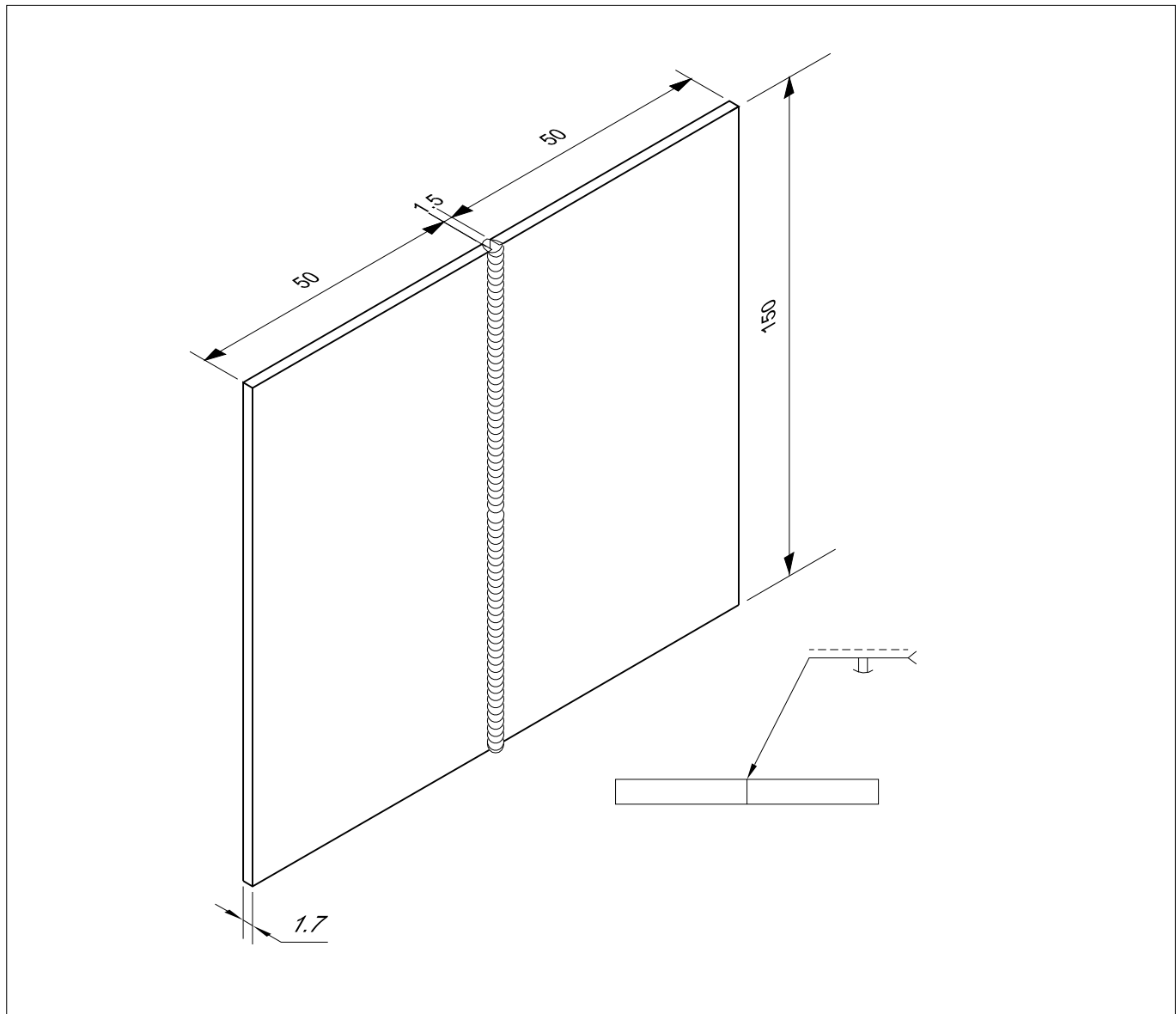
Inspect the weld bead for surface defects like undercut, poor bead appearance due to sagging of weld metal, excessive reinforcement, wavy weld deposit etc.



**Square butt joint on MS sheet 2mm thick in vertical position (3G)-(OAW-11)**

**Objectives:** At the end of this exercise you shall be able to

- prepare and assemble the joint as square butt joint
- set the job in the vertical position with a root gap of 2mm
- select and fix proper size nozzle to the blow pipe
- select proper filler rod and set the gas pressures
- manipulate the blowpipe and filler rod and weld in vertical position by upward method
- ensure proper fusion and root penetration
- clean the job and inspect for weld defects.



2	ISST 50 x 2 - 150	-	Fe 310 - W	-	-	1.3.35
NO.OFF	STOCK SIZE	SEMI-PRODUCT	MATERIAL	PROJECT NO.	PART NO.	EX. NO.
SCALE NTS	<b>SQUARE BUTT JOINT ON M.S.SHEET 2mm THICK IN VERTICAL POSITION (3G)-(OAW-11)</b>				TOLERANCE ±0.5	TIME 8 Hrs
					CODE NO. WLN1335E1	

## Job Sequence

- Shear the plate and file the edges. Clean the surface with a wire brush. Set the plate as a square butt with a 1.5 mm root gap.
- Fix nozzle No. 5 and adjust the gas pressure of oxygen and acetylene at 0.15 kg/cm<sup>2</sup>.
- Ignite the torch and set the neutral flame.
- Select a C.C.M.S. filler rod of 3 mm ø.
- Tack-weld the two pieces with a 1.5 mm uniform root gap on both ends and in center.
- Check for correct alignment.
- Fix the sheet in vertical in the 'C' clamp with the bottom edge of the sheet at welder's chest height.
- Melt the tack weld and establish a weld pool at the bottom edge of the joint.
- Keep the blowpipe angle 75° - 80° to the line of travel and the filler rod angle 30° to 40° to the same plane and proceed to weld upwards.
- Continuously dip the filler rod tip in the molten pool and move upwards. Weld the joint with a single run.
- Ensure the edges of both the metals melt equally so as to achieve complete penetration.
- At the end of the joint add sufficient filler metal and fill up the crater. Use a pair of tongs to remove the job from the fixture.
- Clean the weld and inspect for surface defects and root penetration.

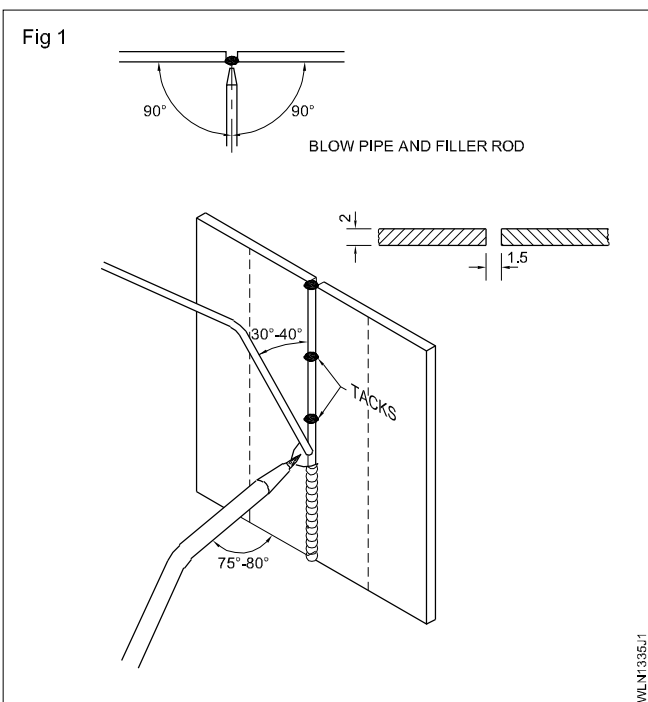
## Skill Sequence

### Square butt joint on MS sheet 2mm in vertical position

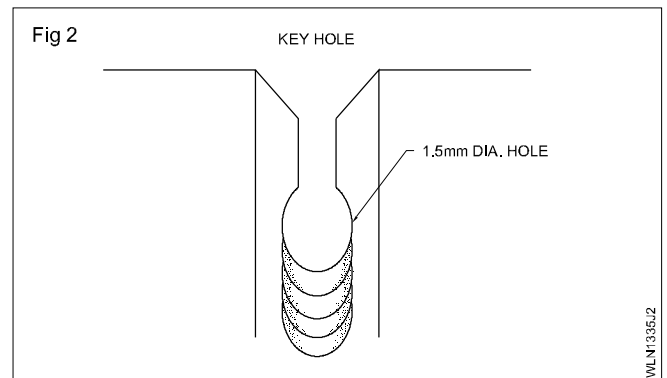
**Objective:** This shall help you to

- **prepare and weld square butt joint on MS sheet 2mm in vertical position.**

Tack the two sheets together as a square butt joint and fix the job in vertical position. (Fig 1)



Move the torch to the bottom of the square groove and establish a weld puddle. Continue to develop the puddle until you see the keyhole (Fig 2) that indicates complete penetration.



When you achieve the desired penetration, begin adding filler metal and proceed welding upwards. (Fig 1)

Use a slight side to side weaving to the blow pipe to ensure fusion of both the edges of the joint.

Progress upward at a uniform rate of travel and add filler metal to get a bead of even width with good profile and appearance.

End the weld at the top of the joint and ensure to fill the crater.

Clean the bead and check whether there is uniform root penetration for 0.5mm depth, a weld reinforcement of 0.5 to 1mm and no undercut etc.

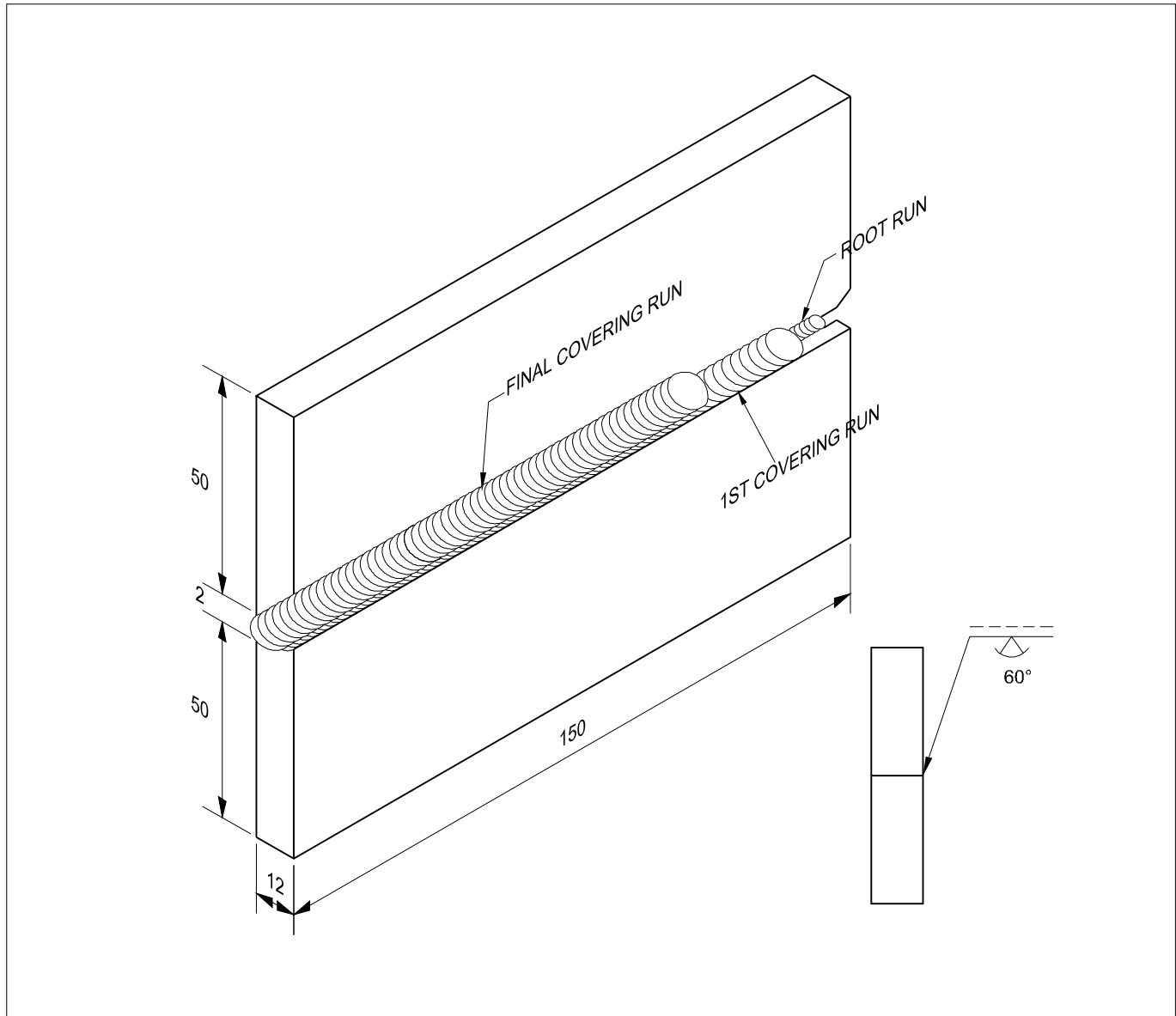


Scan the QR Code to view the video for this exercise

**Single "V" butt joint on MS plate 12mm thick in horizontal position (2G)-(SMAW-11)**

**Objectives:** At the end of this exercise you shall be able to

- prepare the plate edges to prevent effect of gravity on deposited metal
- maintain root penetration by the manipulation of electrodes
- weld single 'V' butt joint in horizontal position preventing sagging of weld metal
- clean and inspect for surface defects.



2	50 ISF 12 - 150	-	Fe 310 - W	-	-	1.3.36
NO.OFF	STOCK SIZE	SEMI-PRODUCT	MATERIAL	PROJECT NO.	PART NO.	EX. NO.
SCALE NTS	<b>SINGLE "V" BUTT JOINT ON M.S PLATE 12mm THICK IN HORIZONTAL POSITION (2G) -(SMAW-11)</b>				TOLERANCE ±1	TIME 9 Hrs
					CODE NO. WLN1336E1	



## Job Sequence

- Cut the MS plates 10mm thick to size.
- Bevel the edges.
- One of the plates is beveled to 45° by gas cutting.
- The second plate is beveled to 15° by gas cutting.
- Clean the edges and remove all the burrs.
- Preset the single 'V' for controlling the distortion.

**Wear safety clothing.**

- Tack the beveled plates with a root gap of 2 mm.

- Fix the joint in horizontal position such that the member with 45° bevel as the top member with 15° beveled member as the bottom member.
- Deposit the root run starting from top plate and fuse the bottom plate also. Maintain uniform penetration throughout.
- Deposit 2nd and final 3rd run to complete the joint in horizontal position.
- Deslag each run and clean the bead.
- Inspect the welded joint for defects.

## Skill Sequence

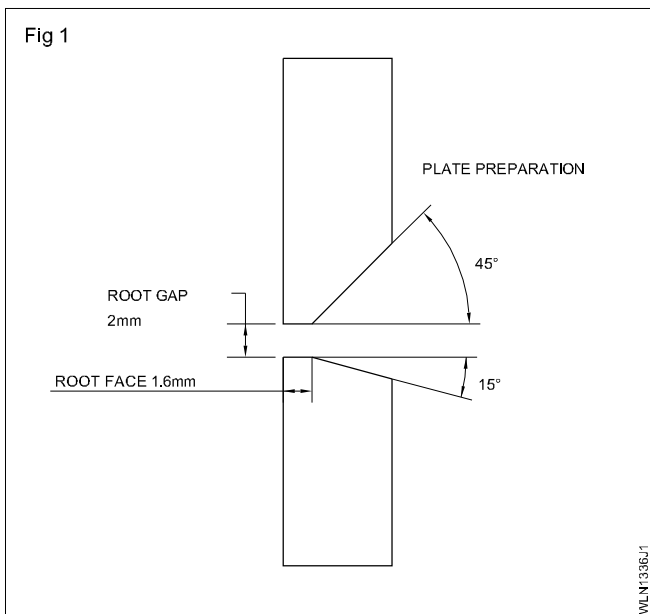
### Single 'V' butt joint on MS plate 12mm thick in horizontal position

**Objective:** This shall help you to

- **prepare and weld single V butt joint on MS plate 12mm thick in horizontal position.**

Prepare the beveling by gas cutting and filling.

Prepare the plate and make 45° bevel for the top member and 15° bevel for the bottom member with a root face of 1.5 mm by filing. Fig 1



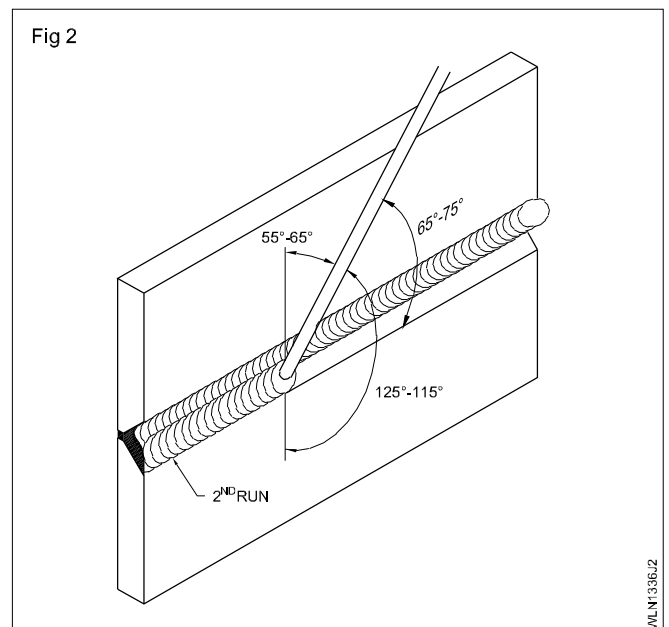
Then file the bevel and keep the root face 1.5 mm. (Fig 1) Set the job with a 2 mm root gap and tack weld on both ends.

This type of beveling is used specially for welding single 'V' butt joint in horizontal position to deposit the metal against the effect of gravity.

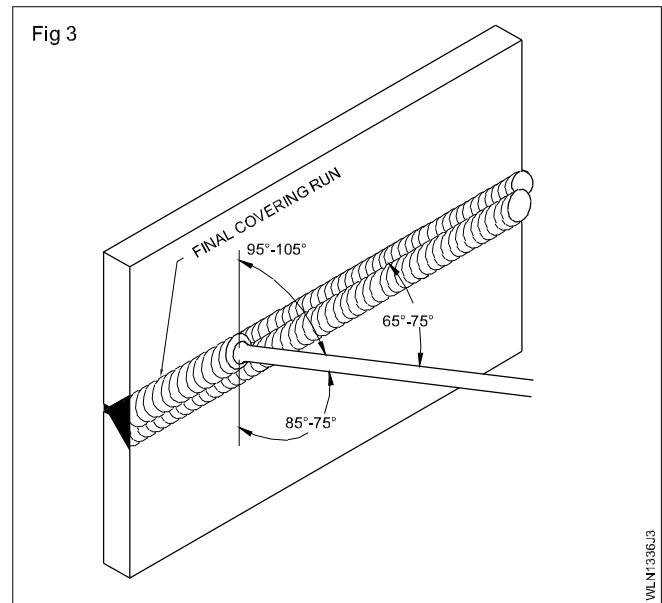
Deposit a root run without weaving motion and hold the electrode angle 90° to the vertical plate and 65° to 75° to the line of the joint.

Maintain the keyhole to obtain uniform penetration.

Deposit the 2nd run by reducing the electrode angle to the upper vertical plate 55° to 65° using slight weaving motion. (Fig 2)



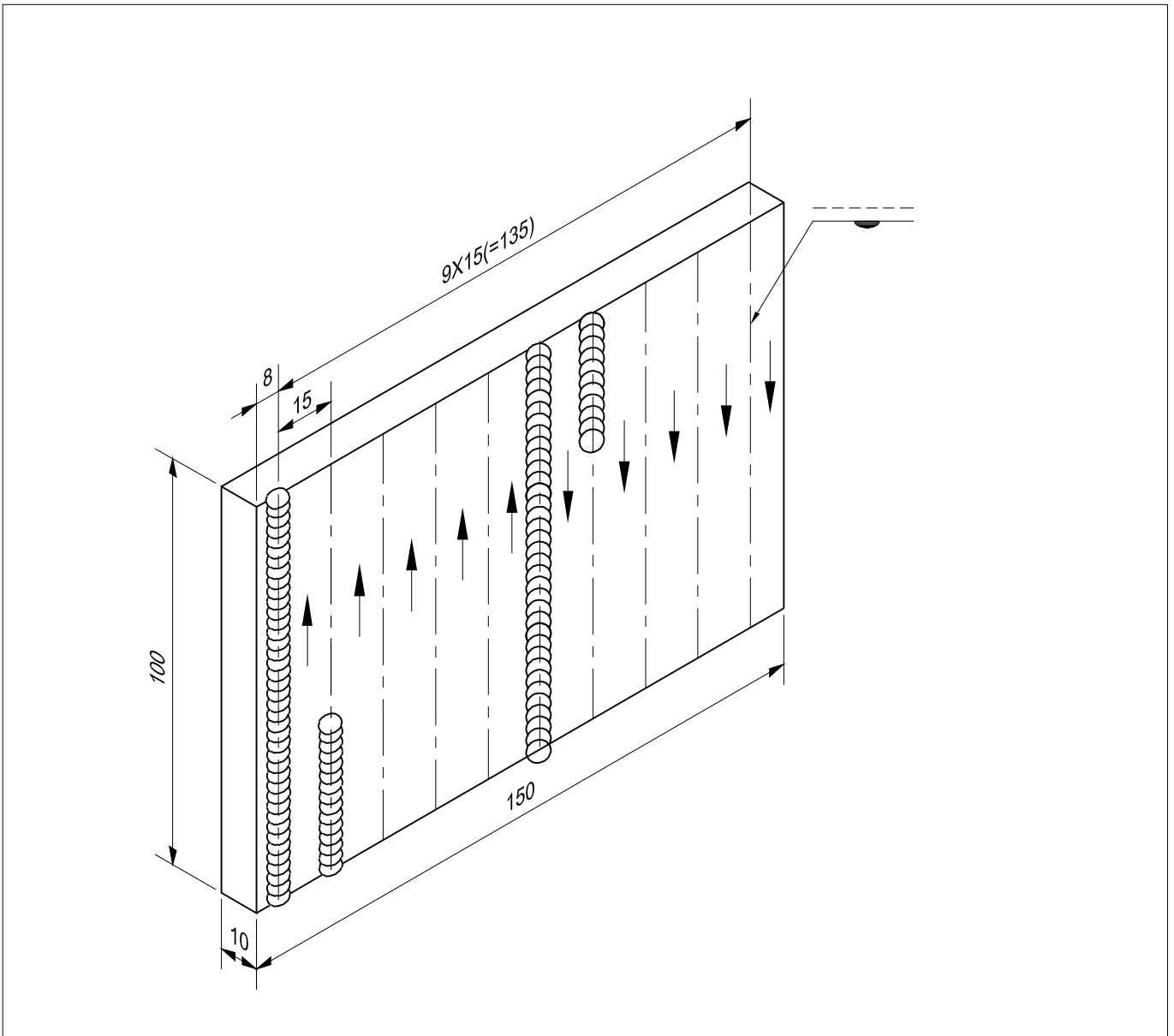
Deposit the 3rd run by increasing the electrode angle  $95^\circ$  to  $105^\circ$  to the upper vertical plate using slight weaving motion. (Fig 3) Deposit the outer edge of the upper fusion face and the junction of the 2nd run.



**Weaved beads on MS plate 10mm thick in vertical position (SMAW-12)**

**Objectives:** At the end of this exercise you shall be able to

- fix the jobs in vertical position using positioner
- select the electrode, current, polarity and arc length
- deposit bead with uniform width on the surface of the plate in upward and downward direction
- clean and inspect the welds for bead uniformity and surface defects.



1	100 ISF 10 - 150	-	Fe 310 - W	-	-	1.3.37
NO.OFF	STOCK SIZE	SEMI-PRODUCT	MATERIAL	PROJECT NO.	PART NO.	EX. NO.
SCALE NTS	<b>WEAVED BEADS ON M.S. PLATE 10 mm THICK IN VERTICAL POSITION (SMAW-12)</b>				TOLERANCE ±1	TIME 8 Hrs
					CODE NO. WLN1337E1	

## Job Sequence

### Vertical upward

- Cut the MS plate 10mm thick to size.
- Mark straight lines as per drawing and punch mark the lines.
- Position the plate vertically by the fixture at a convenient height.
- Set the current 100 amps suitable for 3.15mm electrode to deposit the bead vertically upwards.
- Wear safety apparels.
- Strike the arc and deposit the straight line bead in vertical position till the weld reaches the top edge.
- Fill the crater by striking and breaking the arc at the top end of the bead.
- Repeat the upward welding for another 4 beads.

### Vertical downward

- Strike and maintain a long arc at the starting point on the top edge of the 6th line.
- Move the electrode downwards reducing the arc length to a short arc.
- Ensure to keep the molten slag away from the molten pool by holding the electrode at proper angle.
- Maintain a faster speed of travel of the electrode downwards than the speed used for upward welding.
- Stop the downward movement of the electrode for 1 or 2 seconds at the bottom edge of the bead to fill the crater.
- Deslag and clean the beads.
- Repeat the downward welding for another 4 beads.
- Check the size, shape and ripples of all the beads and also check for surface defects.

## Skill Sequence

### Weaved bead on MS plate 10mm thick in vertical position

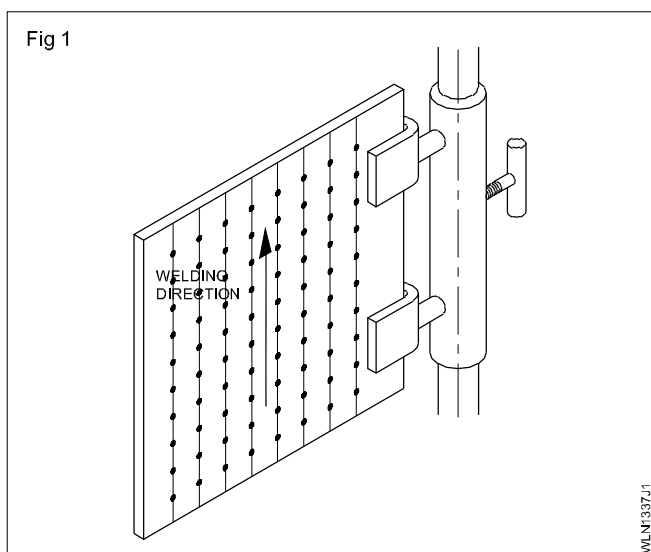
**Objective:** This shall help you to

- **prepare and make weaved bead on MS plate of 10mm thick in vertical position.**

#### Preparation

Cut the plate to size by gas cutting, grind the edges to square and remove burrs by filing or by grinding. After cleaning the surface, mark and punch a straight line. 5 lines are to be used for vertical upward and 5 lines for vertical downward.

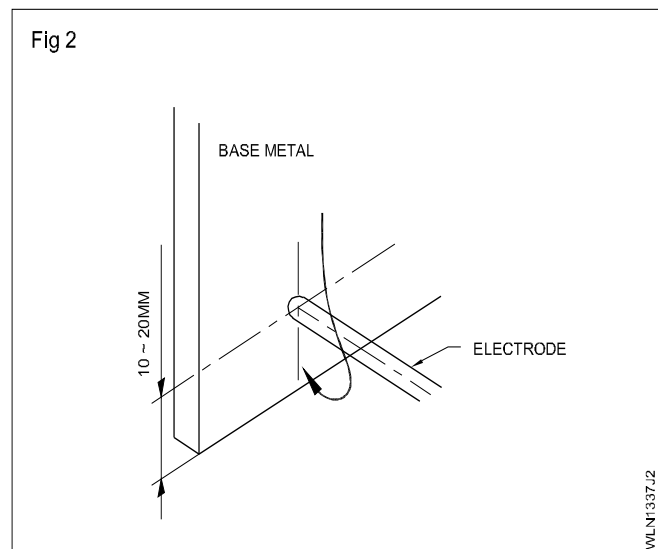
Fix the plate in vertical position. (Fig 1)



#### Vertical Up

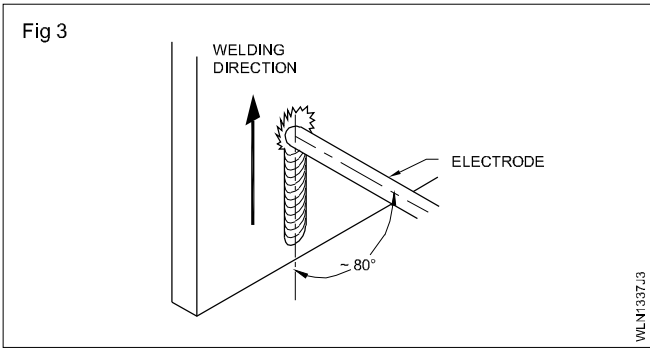
Use a 3.15 mm dia. electrode with 100 amps current; use less current than in flat position welding for the same thickness of plate so as to maintain a small molten pool.

Deposit straight line bead in vertical position with an electrode movement slightly sideways, and in a steady upward direction. (Fig 2)

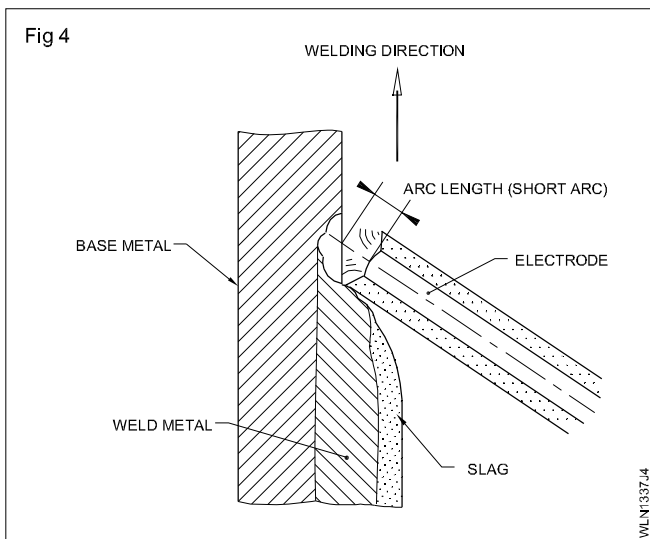


Run the electrode cable over the shoulder to reduce the strain on the hand while moving the electrode holder in the upward direction.

Maintaining the angle of electrode  $80^\circ$  to the line of weld. (Fig 3) and ensure uniform speed of welding in the vertical direction.



**Maintain a short arc to get uniform fusion and to protect the weld metal rolling down due to gravity. (Fig 4)**



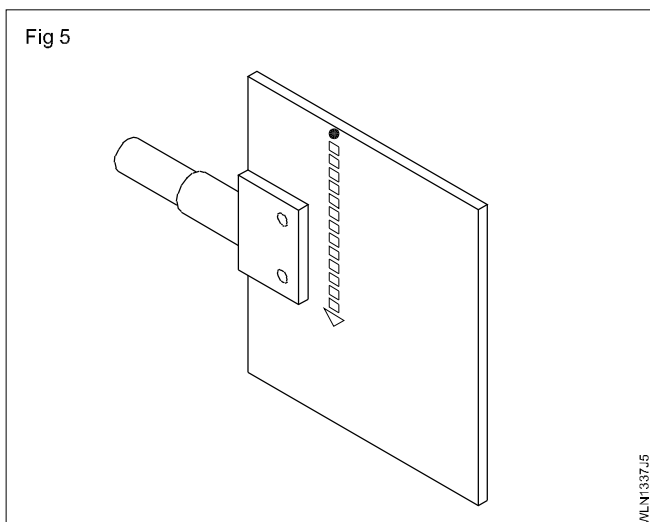
Deslag and clean the weld bead.

**Avoid long arc length.**

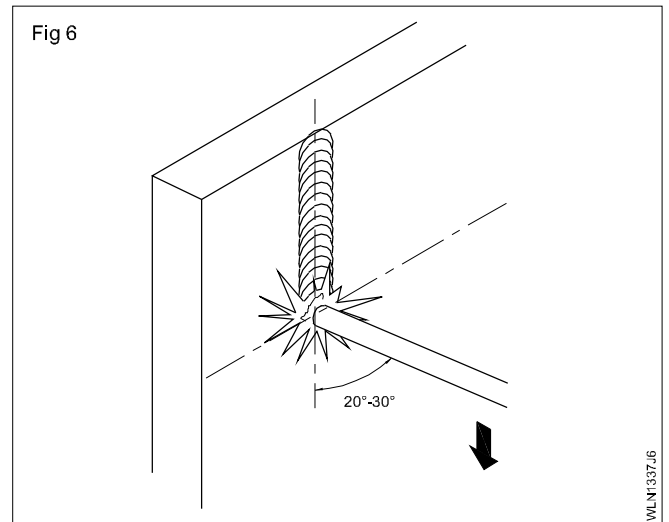
### Vertical Down

Select an electrode of 3.15 mm dia. designed for welding vertically downwards, and set a current of 100 amps. Use straight polarity in the case of DC machines.

Start welding at the top of the work piece along the 6th marked line. Fig 5

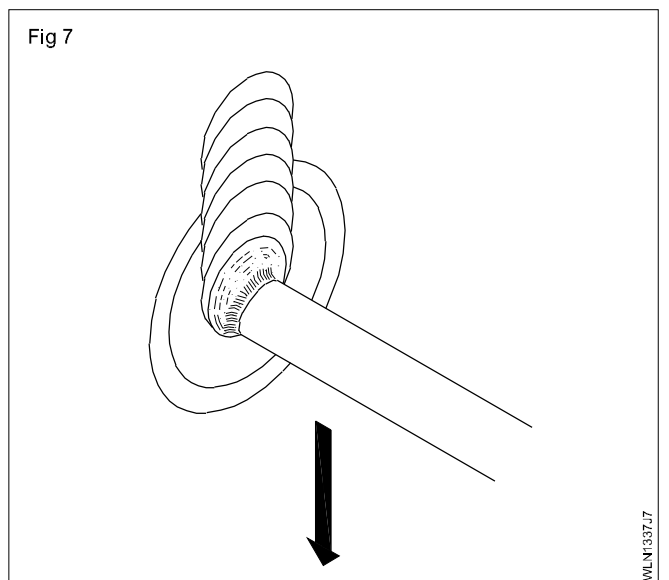


Keep the electrode at right angle to the work piece, holding it slightly below the horizontal as shown in Fig 6.



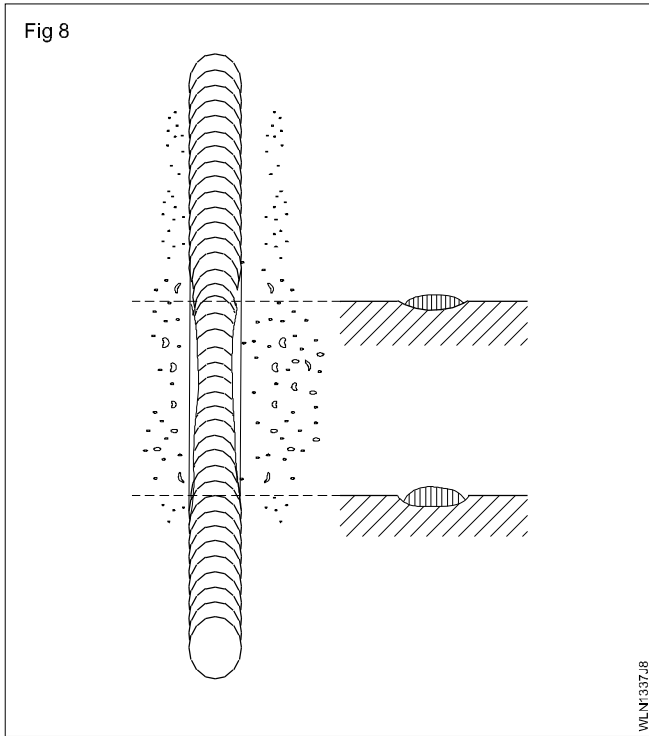
Adjust the welding speed to get good fusion on the surface. Use a short arc. The welding speed should be faster than the speed used for vertical up welding.

Adjust the electrode angle to control the slag. If the slag is flooding the crater, the electrode must be held at a steeper angle as shown in Fig 7. Weld up to the bottom end of the work piece.



Check the weld for: (Fig 8)

- good weld size, shape and ripple formation
- no undercuts
- straight runs
- slag inclusions.



## Laying weaved beads, MS plate 10mm (Vertical upward) position vertical

**Objectives:** This shall help you to

- select the electrode, current, polarity and arc length
- deposit weaved beads in vertical position without sagging
- control the molten metal and slag by the manipulation of electrodes
- inspect the surface defects in vertical welding.

### Depositing weaved beads on M.S. plate in vertical upward position.

- Prepare the plate to size as per drawing.
- Mark parallel lines and punch.
- Set the job on the vertical position on the welding table using the positioner.
- Adjust the height of the positioner to suit the welder.

#### Wear safety protective clothing.

- Select a M.S. electrode 3.15 mm  $\varnothing$  and set 100-110 amps.
- Start welding at the bottom edge of the punched line.
- Keep the angle of the electrode  $80^\circ$  to the line of weld.
- Weld with a slight movement of the electrode from side to side.

#### Stop for a moment at the sides of the weld to avoid undercut.

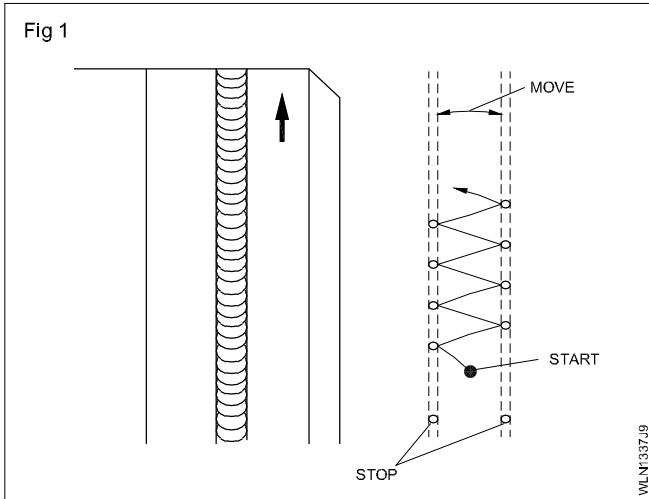
- Make weaved beads between parallel lines.
- The slag will be controlled by the manipulation of the electrode angle and maintaining a short arc length.

- Weld towards the top of the work piece and finish the run. Fill the crater.
- Deslag and clean the weld with a wire brush.  
(Repeat the exercise until you can make sufficiently good beads.)
- Inspect the weld for defects.

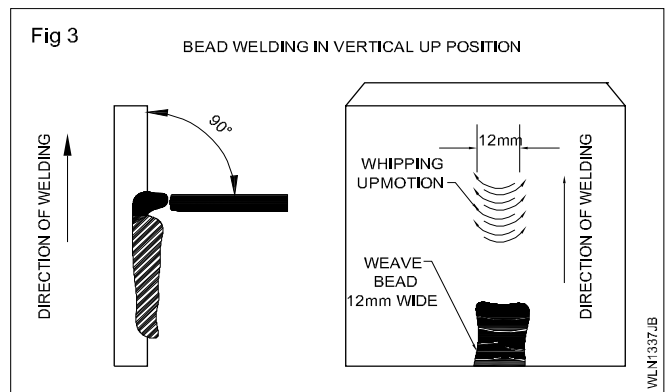
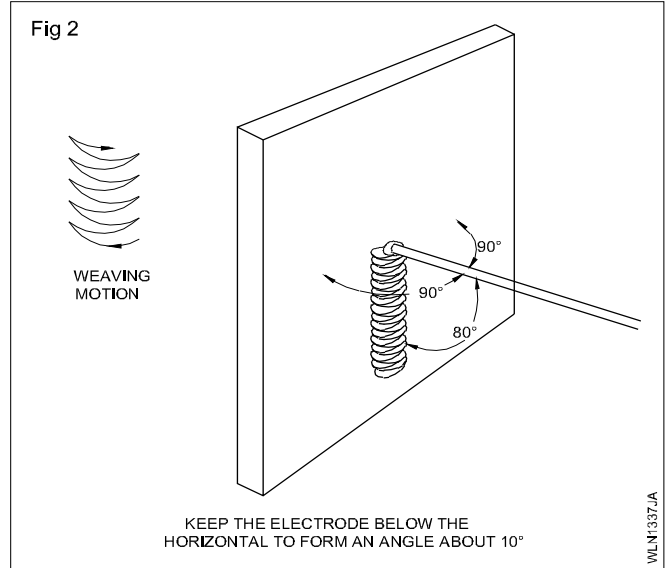
Welding in vertical position is always a problem as the molten metal rolls down due to gravity. This can be overcome by using special techniques or methods.

Use a short arc for depositing weaved beads. This will avoid sagging of molten metal and liquid slag. The angle of the electrode should be  $10^\circ$  less than the right angle to the line of weld. (Fig 2) Use minimum current i.e. 100 to 110 amps for a 3.15 mm electrode. Generally 10% less ampere than the current used for the same dia. of electrode in down hand position is used so as to maintain a small molten pool and prevent sagging.

The motion of the electrode should be side-to-side weaving. (Fig 1 & 2) Whip and lift the electrode upward on either side of the weaving motion. (Fig 3) The rate of travel should be uniform for obtaining uniform bead ripples with good appearance.



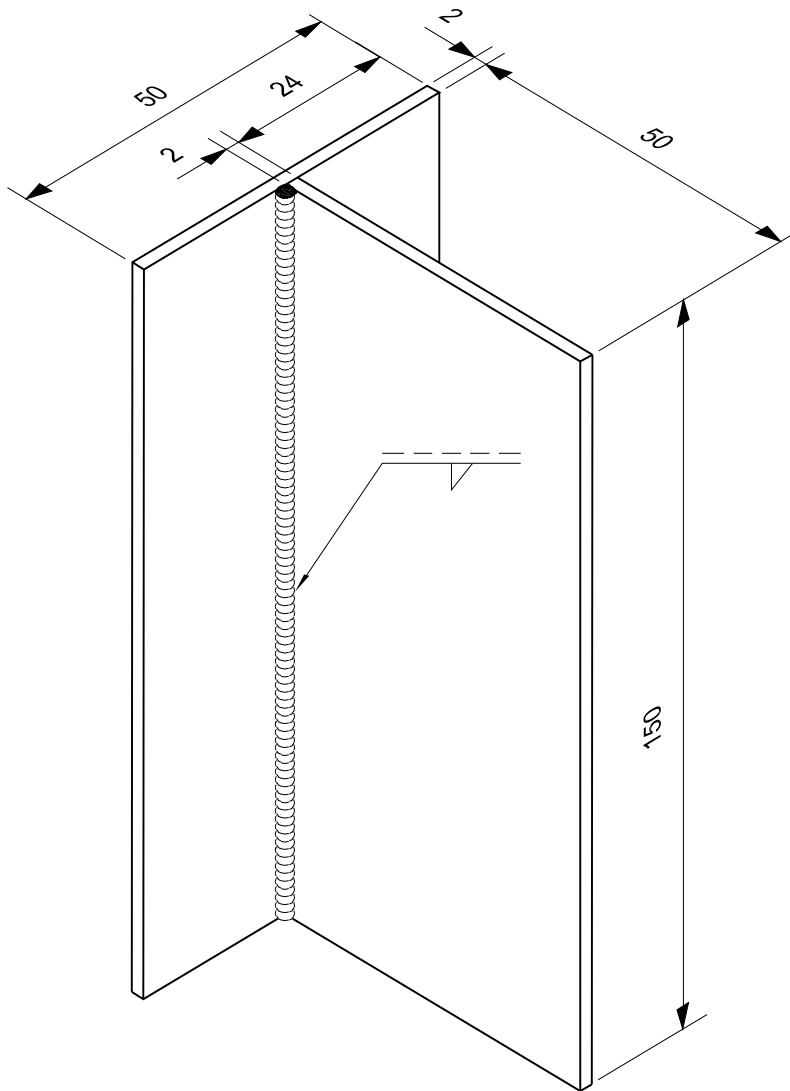
Fill the crater at the end of the bead. Deslag the weaved bead and clean with a wire brush. Check for uniform ripple formation, width of bead and no undercuts.



**Fillet 'T' joint on MS sheet 2mm thick in vertical position (3F)-(OAW-12)**

**Objectives:** At the end of this exercise you shall be able to

- set the job pieces and tack as fillet tee joint
- select nozzle size, filler rod and set gas pressure for welding
- manipulate the blow pipe and filler rod to deposit weld metal in vertical upward direction
- deposit the weld bead without allowing sagging of molten metal
- ensure the root penetration
- clean the joint and inspect for weld defects.



2	ISST 50 x 2 - 150	-	Fe 310 - W	-	-	1.3.38
NO.OFF	STOCK SIZE	SEMI-PRODUCT	MATERIAL	PROJECT NO.	PART NO.	EX. NO.
SCALE NTS	<b>FILLET 'T' JOINT ON M.S SHEET 2mm THICK IN VERTICAL POSITION (3F)-(OAW-12)</b>				TOLERANCE ±0.5	TIME 8 Hrs
					CODE NO. WLN1338E1	



## Job Sequence

- Prepare the material as per drawing and file the edges to square. Clean the surface with a wire brush.
- Select nozzle No. 5 and a 1.5mmø C.C.M.S. rod. Set the neutral flame.
- Set gas pressure at 0.15 kg/cm<sup>2</sup>.
- Wear protective leather clothing and welding goggles.
- Tack the work piece as a 'T' joint.
- Ensure the joint is clamped properly in the fixture in the vertical position and the line of weld becomes perpendicular to the ground.
- Start welding the joint from the bottom in the upward direction manipulating the blow pipe and filler rod properly.
- Maintain proper angles for the blow pipe and filler rod between the sheet surfaces and to the line of weld so that the root and the surfaces joined will melt properly.
- Ensure the molten puddle does not sag too much due to gravity.
- At the end of the joint fill up the crater and complete the weld.
- Remove the work piece from the fixture and clean the weld bead.
- Inspect the weld bead for equal leg length, uniform ripple and ensure it is free from surface defects.

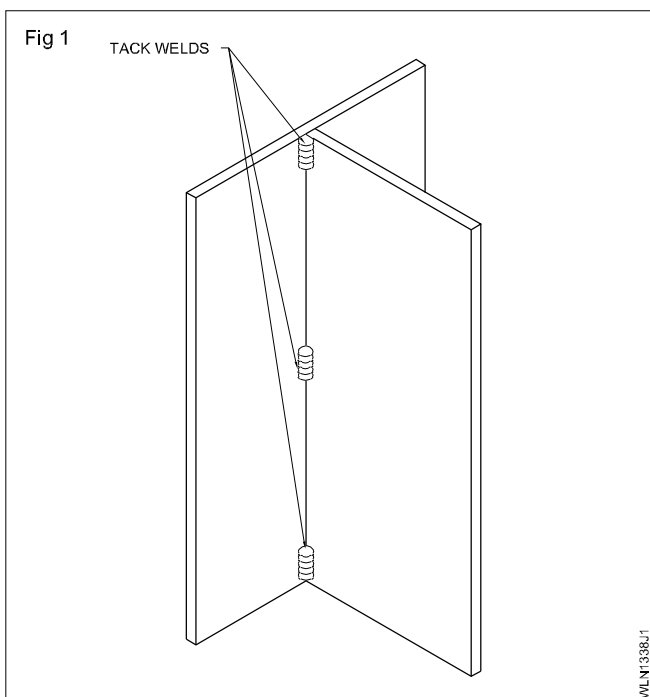
## Skill Sequence

### Fillet 'T' weld in MS sheet 2mm in vertical position

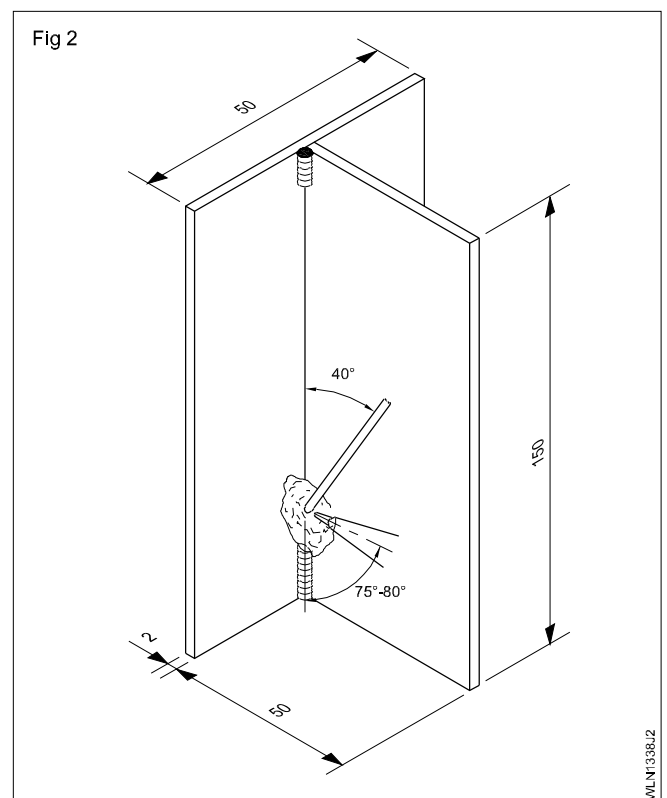
**Objective:** This shall help you to

- **prepare and weld fillet 'T' weld in MS sheet 2mm in vertical position.**

Keep one of the sheets vertically at 90° to the bottom sheet (Fig 1) and tack weld using neutral flame at the ends of the joint in proper alignment and at the center.



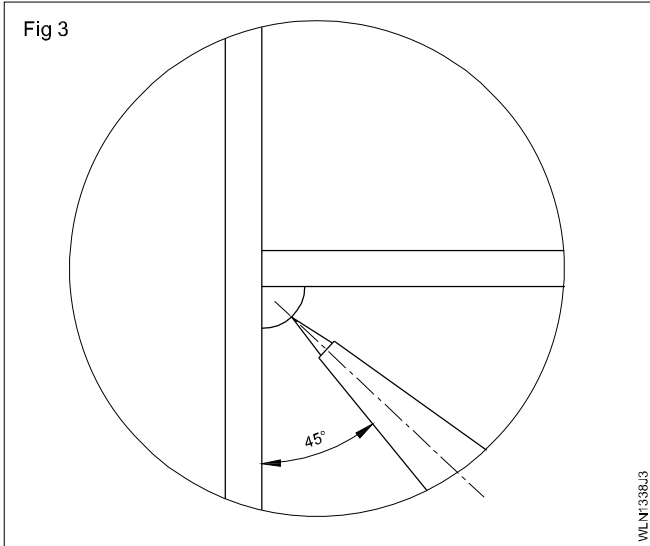
Maintain the angle of the blowpipe at 75-80° and filler rod at 40° respectively to the line of weld in vertical upward direction. (Fig 2) Also maintain a blowpipe angle of 45° between the sheet surfaces. (Fig 3)



Control the molten pool steadily and weld the fillet joint on the root by melting both the surfaces to be joined equally.

Dip the end of the filler rod continuously in the molten pool and proceed welding upward.

Fig 3



The above mentioned procedure will help to fuse the root and both the sheet surfaces of the joint uniformly as well as control sagging of molten metal deposited into the joint.

Ensure uniform speed of torch travel against the gravitation pull of the hand due to the weight of blowpipe, hose etc.

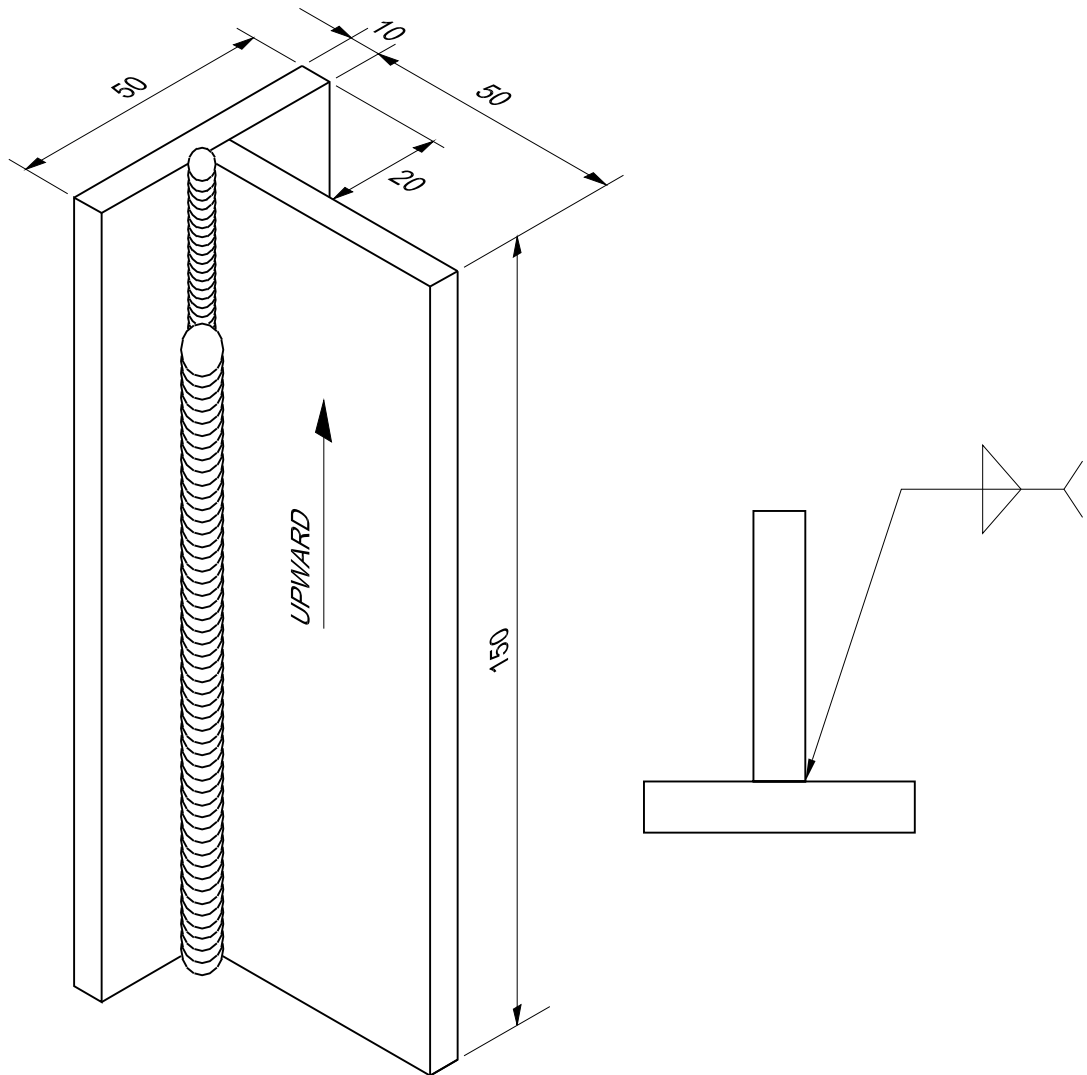


Scan the QR Code to view the video for this exercise

**Fillet - "T" joint on MS plate 10mm thick in vertical position (3F)-(SMAW-13)**

**Objectives:** At the end of this exercise you shall be able to

- fix the joint in vertical position
- deposit the root run in vertical position ensuring root penetration with short arc
- deposit the second run evenly to get the required fillet size without defects
- inspect for surface defects like undercut, lack of penetration etc.



2	50 ISF 10 - 150	TO EX.NO.28	Fe 310 - W			1.3.39
NO.OFF	STOCK SIZE	SEMI-PRODUCT	MATERIAL	PROJECT NO.	PART NO.	EX. NO.
SCALE NTS		<b>FILLET - "T" JOINT ON M.S PLATE 10mm THICK IN VERTICAL POSITION (3F)-(SMAW-13)</b>			TOLERANCE ±1	TIME 9 Hrs
					code no. WLN1339E1	

## Job Sequence

- Mark the plate to size and cut as per drawing.
- Prepare square edges.
- Set the work piece as a 'T' joint.
- Select a 3.15 mm electrode and set 110 amps current.
- Connect electrode cable to -ve terminal.
- Tack-weld the work pieces at the ends.

**Preset the plates to 2° to take care of distortion.**

- Position the joint in vertical in the welding positioner.
- Deposit the root run with short arc length and by a slight weaving up and down motion to the electrode.
- Use whipping action for the electrode.

- Deslag and clean thoroughly with a wire brush.

**Use goggles while Deslagging.**

- Select a 4 mm  $\varnothing$  electrode and set 160 amps current.
- Deposit 2nd run with short arc using a weaving motion and uniform speed of metal deposition.
- Avoid undercut.
- Ensure proper crater filling.
- Remove the welded joint from the positioner, clean and inspect for defects.

**Follow the necessary safety precautions during welding.**

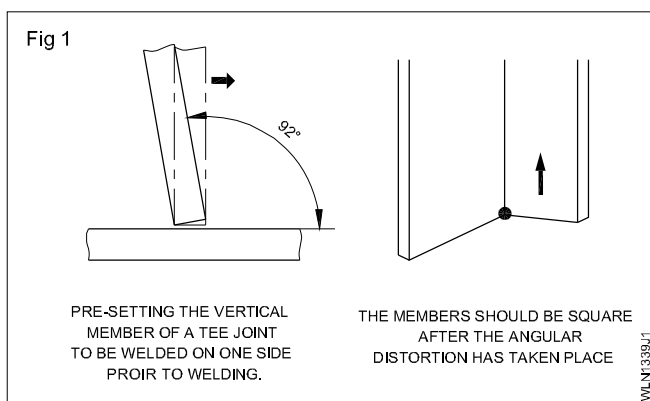
## Skill Sequence

### Fillet weld 'T' joint on MS plate 10mm thick in vertical position

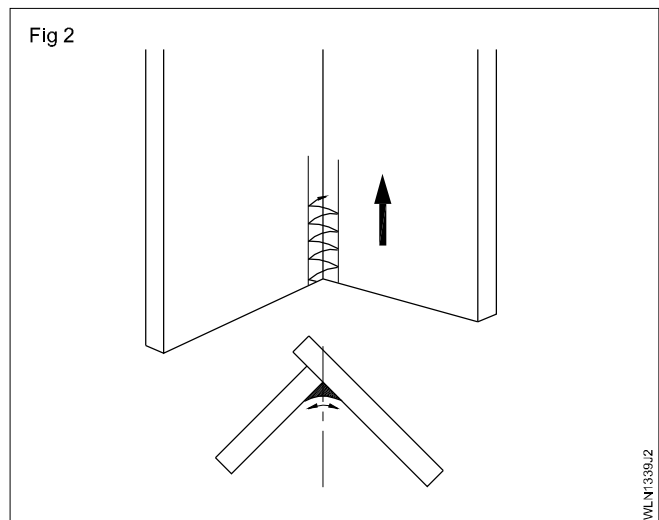
**Objective:** This shall help you to

- prepare and fillet weld 'T' on MS plate 10mm thick in vertical position.

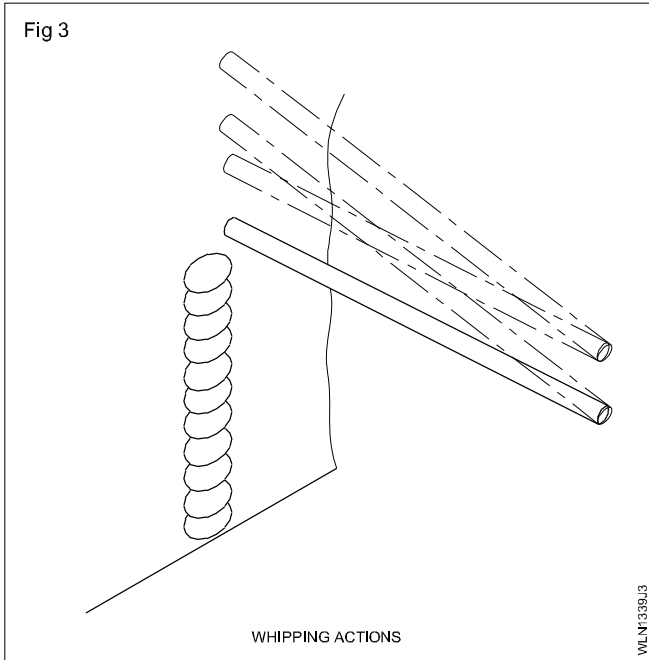
In vertical welding the difficulty to be overcome is the inclusion of slag in the weld metal, undercut and control of molten metal from sagging. These are avoided by using a short arc and proper weaving technique with a correct electrode angle. Preset the plate at 1° per run as shown in Fig 1 to take care of angular distortion. While depositing the root run start from the lowest part of the work piece. (Fig 2)



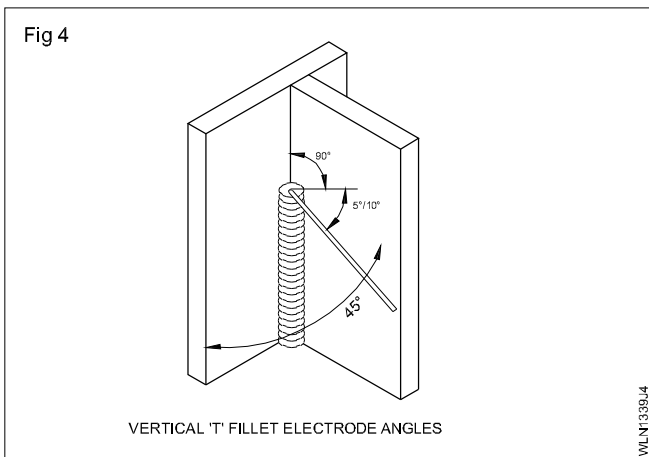
**Depositing root run:** Ensure equal deposit of weld metal on both the plates by giving a slight weaving motion.



Use whipping action for the electrode (Fig 3). During whipping action, the electrode is raised away from the molten pool a little with a long arc and again brought back closer to the molten pool with a short arc. When the electrode is raised from the molten pool, the weld metal cools a little and partly solidifies which helps in reducing the sagging effect of the molten weld metal.

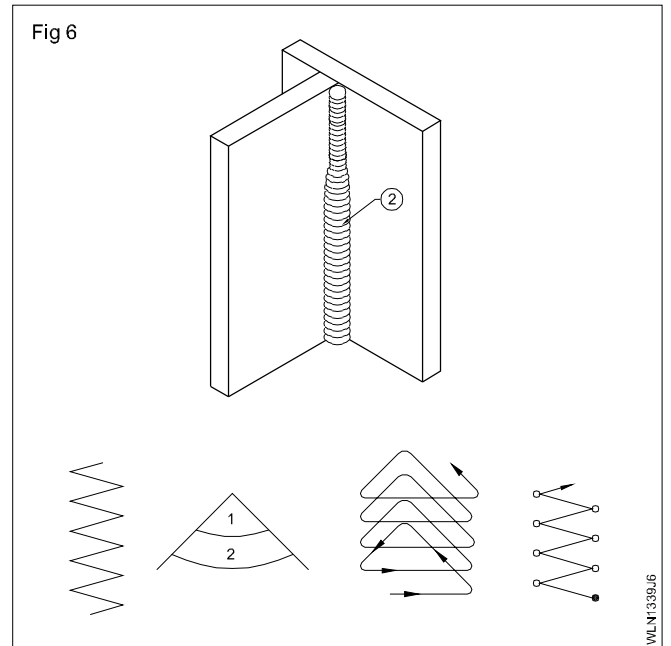
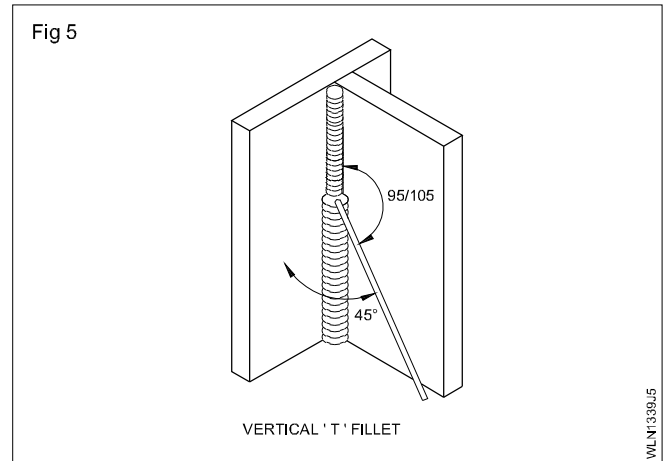


Move the electrode from side to side and stop for a short moment at each side to avoid undercut. Keep the angle of the electrode as shown in Fig 4 to deposit the metal at proper place in the joint without sagging.



Clean thoroughly the root run, and specially any slag at toes should be removed.

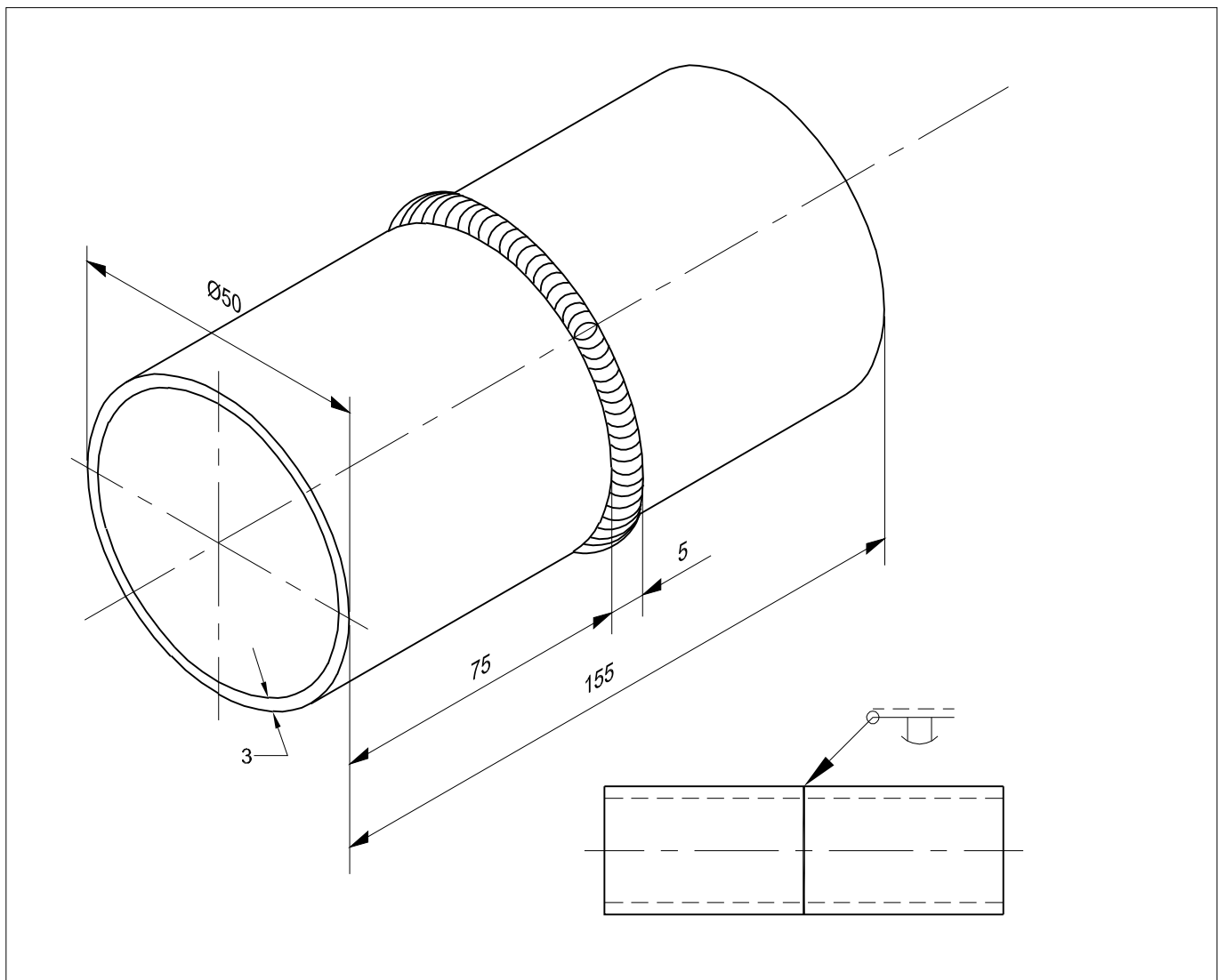
Weld the second run to get a uniform bead of required size. Use a zigzag or triangular movement of the electrode as shown in Fig 6. Use short arc length and stop a while at the sides to fill the weld at the toes. The electrode tip pointing upwards due to the electrode angle Fig 4 and the use of short arc and the weaving technique will control the sagging of the weld metal and the slag inclusion. The stoppage of the electrode at the toes of the weld for a moment in the weaving motion will help to avoid undercuts.



**Structural pipe welding butt joint on MS pipe  $\varnothing 50\text{mm} \times 3\text{mm}$  wall thickness in 1G (Rolling) position (OAW-13)**

**Objectives:** At the end of the exercise you shall be able to

- cut and prepare the MS pipe as per the dimension given in the drawing
- align the axis of the pipes in flat position as a pipe butt joint
- select nozzle, filler rod sizes, gas pressures and flame
- set the root gap and tack weld the pipes
- set the tack welded pipes with their axes horizontal
- weld the butt joint in segments ensuring proper root penetration, bead size, profile and reinforcement
- clean and inspect for surface defects.



2	$\varnothing 50 \times 3 - 77$	-	Fe 310 - W	-	-	1.3.40
NO.OFF	STOCK SIZE	SEMI-PRODUCT	MATERIAL	PROJECT NO.	PART NO.	EX. NO.
SCALE NTS		<b>STRUCTURAL PIPE WELDING.PIPE BUTT JOINT ON M.S.PIPE <math>\varnothing 50 \times 3\text{mm}</math> WALL THICKNESS IN 1G (ROLLING)POSITION (OAW-13)</b>			TOLERANCE $\pm 1$	TIME 15 Hrs
					CODE NO. WLN1340E1	

## Job Sequence

- Cut the pipes to 77mm length by hacksaw and file its end square to 75mm length. Chamfer the outside edge of the pipe to 30 - 35° angle leaving a root face/land of 1.5mm at the bottom edge of the pipe.
- Clean the inside and outside surfaces of the cut pipes after deburring.
- Fix No. 5 size nozzle, select 1.6mm $\varnothing$  CCMS filler rod and set 0.15 kg/cm<sup>2</sup> pressure for both gases.
- Set the 2 pipes on an angle or channel fixture to form a coaxial pipe butt joint with proper root gap.
- Follow necessary safety precautions.
- Set neutral flame.
- Tack weld in 3 places (120° apart) keeping 1.5mm root gap between the pipes.
- Divide the pipe circumference into four segments. Keep the pipe horizontally on the fixture.
- Deposit the root run starting from 3 o'clock position to 12 o'clock position using proper blowpipe and filler rod angles. (I segment)
- Turn the pipe joint in the clockwise direction so that the end of the root run already made in I segment comes to the 3 o'clock position.
- Continue to weld the root run for the second quarter segment as done for the first segment.
- Similarly, complete root run of 3<sup>rd</sup> and 4<sup>th</sup> segments.
- Ensure the root penetration by maintaining a keyhole at the root throughout the root run.
- Clean the root run by steel wire brush.
- Fix No. 7 size nozzle, select 3mm $\varnothing$  CCMS filler rod and set 0.15 kg/cm<sup>2</sup> gas pressure.
- Set neutral flame and fill the V groove by depositing the 2nd run using slight weaving to the blowpipe so that both the faces of the V and the root run will fuse properly.
- Ensure proper bead size, profile and weld reinforcement as well as avoid undercut and other weld defects.
- Clean the joint and inspect for external defects.

## Skill Sequence

### Structural pipe welding butt joint on MS plate $\varnothing 50 \times 3$ mm wall thickness in 1G (Rolling) position

**Objective:** This shall help you to

- **prepare and weld structural pipe welding butt joint on MS plate  $\varnothing 50 \times 3$  mm wall thickness in 1G (Rolling) position.**

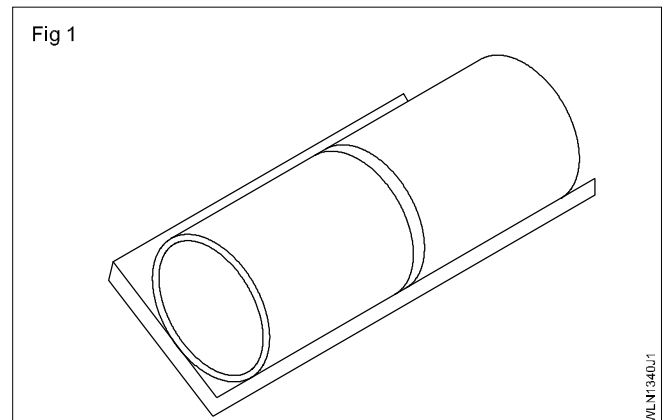
Pipe welding is a highly skilled welding operation, which involves correct alignment and good penetration by equally melted edges of the pipes. As the welding is to be done on a curved surface, the position of the blow pipe and filler rod will continuously change as the welding progresses along the joint. To do this you have to put some extra efforts to get the special skill of welding a pipe joint.

**Preparation and setting:** Check and ensure correct size of pipes. Prepare two M.S. pipes 50 mm  $\varnothing$  and 75 mm long by hacksaw cutting. As the end faces of a pipe cut by a hacksaw may not be at 90° to the pipe axis, file the end faces of the pipe to get the 90° angle. Bevel the ends of the pipes by filing.

Clean the pipes and remove burrs, if any. Align the pipes in flat position as shown in Fig 1. Tack the weld joint by inserting 1.5 mm wire to maintain a uniform root gap. (Fig 2a and 2b) Ensure the tack welded pipes are coaxial. (i.e., the axis of both the pipes are the same.)

Select the angle iron or channel fixture according to the diameter of the pipe.

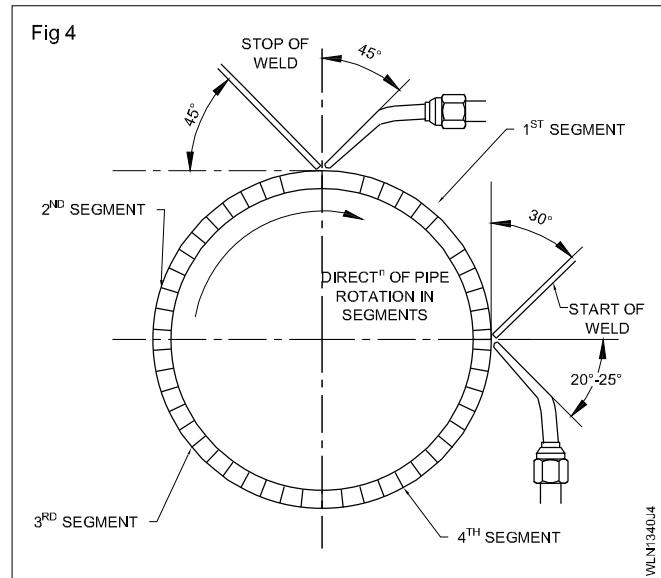
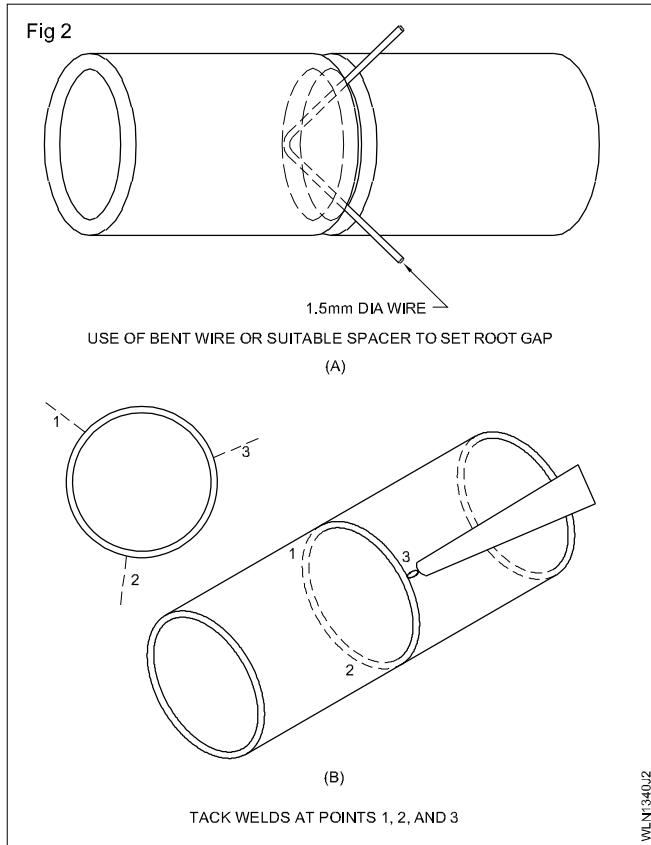
Place the tacked pipes on the fixture.



To ensure proper root penetration select nozzle No. 5 and a 1.6 mm C.C.M.S. rod for the root run.

Start welding as shown in the figure and complete the first segment. (Figs 3 and 4) The blowpipe and the filler rod angles are as shown in Fig 4 at the "start of the weld" and have to be changed to those angles shown at the "stop weld" continuously and gradually. i.e. weld from 3 o'clock position to 12 o'clock position.

After completion of I segment welded, rotate the pipe joint in clockwise direction until the II segment will come to the position of I segment.



**Ensure proper melting of tacks for good penetration and surface appearance.**

It is very important to maintain a keyhole ahead of the molten pool at the root of the joint which will ensure root penetration. Refer Fig 2 of skill sequence of the previous Ex.No.G.29 (2.15).

Remove the work piece from the rotating fixture.

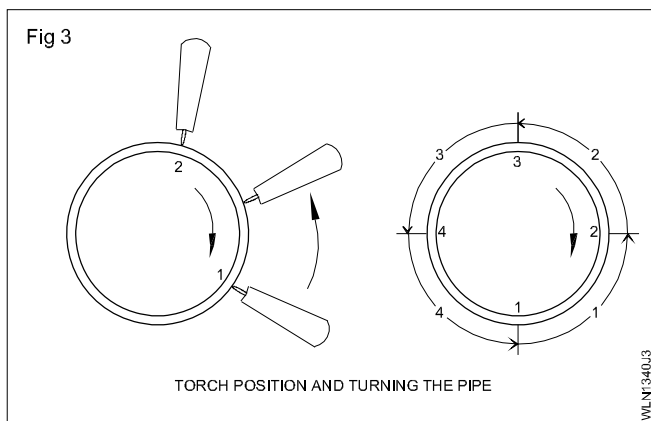
Clean the weld bead and inspect the root run for root penetration and weld defects.

Keep the pipe joint on the rotating fixture and fix no. 7 nozzle, set 0.15 kg/cm<sup>2</sup> pressure for the gases and use 3mm $\varnothing$  CCMS filler rod.

Deposit the final run over the root run using neutral flame.

Follow the same welding technique used for the root run except maintaining a keyhole. Ensure proper fusion of the root run and the side walls of the V groove by proper movement of blow pipe and filler rod.

Ensure undercuts are avoided and proper bead profile, size and reinforcement is maintained. Clean the joint and inspect for weld defects.



Deposit the root run on the II segment similar to the I segment.

Further welding is done by rotating the pipe to the III and IV segment.



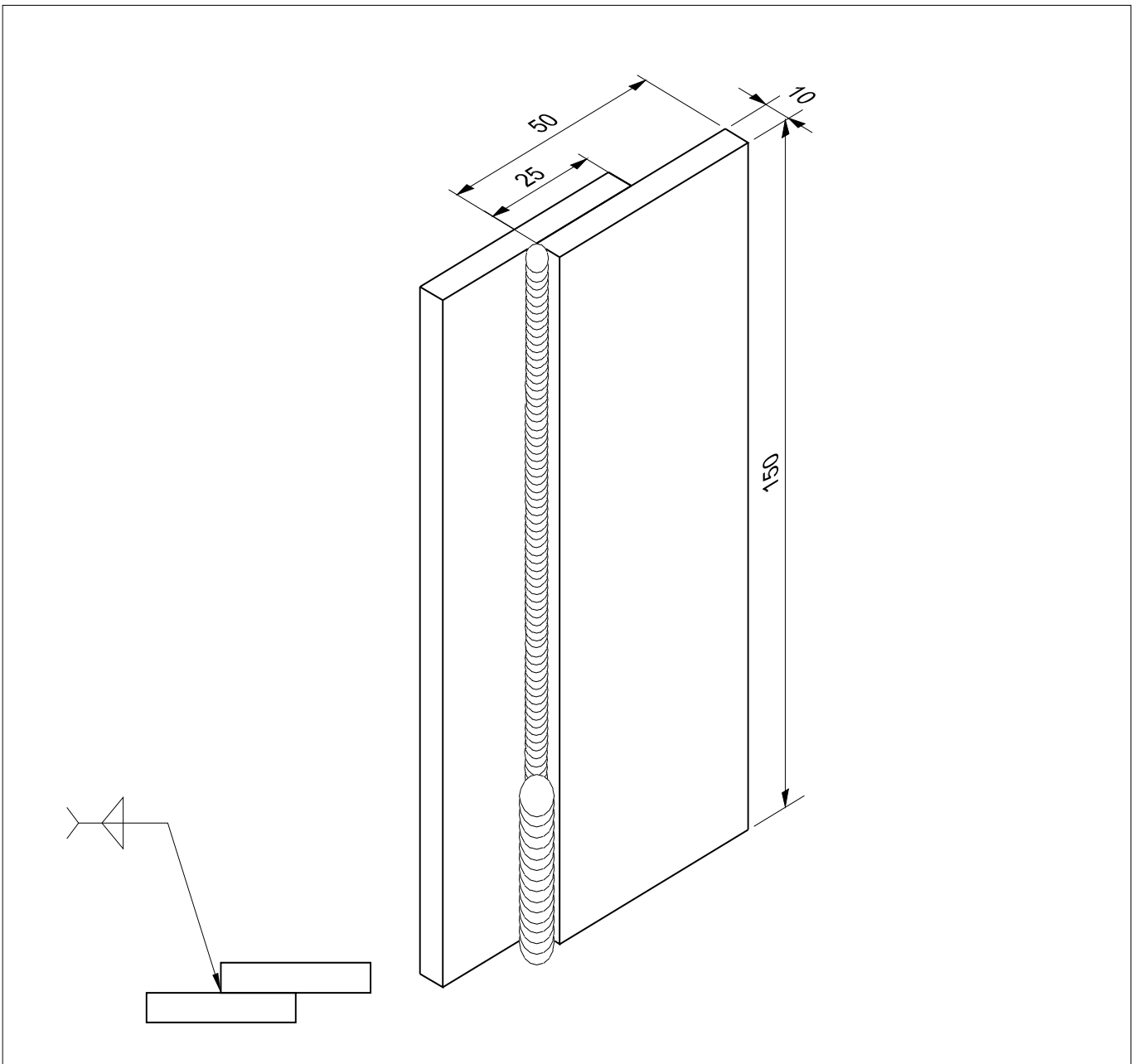
Scan the QR Code to view the video for this exercise



**Fillet - lap joint on MS plate 10mm in vertical position (3G)-(SMAW-14)**

**Objectives:** At the end of this exercise you shall be able to

- deposit bead at the bottom of the joint to the required size of the weld
- control the sagging of the molten metal with an oscillating motion of the electrode
- deposit root run to ensure fusion and penetration in lap section
- complete the weld by depositing second run on the lap joint without edge of plate melted off defect.



2	50 ISF 10 - 150	-	Fe 310 - W	-	-	1.3.41
NO.OFF	STOCK SIZE	SEMI-PRODUCT	MATERIAL	PROJECT NO.	PART NO.	EX. NO.
SCALE NTS	<b>FILLET LAP JOINT ON M.S PLATE 10mm IN VERTICAL POSITION (UPWARD)</b>				TOLERANCE ±0,5	TIME 10 Hrs
					CODE NO. WLN1341E1	

## Job Sequence

- Gas cut the plate "C" to size as per drawing.
- Prepare square edges.
- Clean the flat surface and the edges of plate C.
- Take the T fillet joint already welded under exercise No.
- Assemble/clamp the plate C with the bottom side of plate B of the T fillet joint to form a lap joint as shown in the job drawing. The lapping distance should be 25mm.
- Select a 3.15mm dia. medium coated MS electrode and set 110 amp current.
- Use electrode negative polarity if a DC machine is used for welding.
- Set the assembled job on the welding table and tack weld the plate C with plate B at their ends.
- Ensure that the surfaces of plates B and C are parallel to each other and that there is no gap between them after tacking.
- Remove slag and fix the job on the welding positioner in vertical position.
- Deposit the root run with short arc length and by a very slight weaving motion to the electrode.

- Give whipping action to the electrode to prevent sagging of molten metal and slag.
- Deslag with a chipping hammer and clean the joint and bead thoroughly with a wire brush, particularly at the toes of the weld.

### **Use goggles while deslagging.**

- Select a 4mm dia. medium coated MS electrode and set 150 to 160 amp. current.
- Deposit the 2nd run with short arc and weaving motion.
- The weaving motion and the movement of the arc in the upward direction should be at uniform speed.
- Ensure the correct fillet size with proper bead profile is obtained and the edge of the plate B is not melted off. Also ensure that there is no undercut at the toe of the weld on the bottom plate C.
- Remove the welded joint from the positioner after filling the crater.
- Clean the joint using a wire brush and inspect for any external defect.

### **Follow the necessary safety precautions during welding.**

## Skill Sequence

### **Fillet lap joint on MS plate 10mm thick in vertical position**

**Objective:** This shall help you to

- **prepare and weld fillet lap joint on MS plate 10mm thick in vertical position.**

Welding a lap joint in vertical position has always been a problem - one of the upper edge of the plate being burnt (edge melted off). This can be overcome by using proper electrode manipulation.

#### **Method of depositing bead in vertical on lap joint**

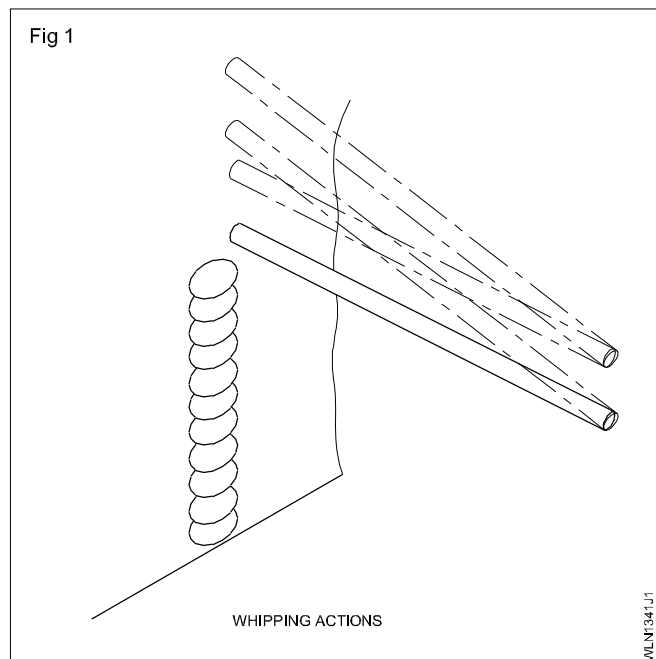
Set a minimum current so as to maintain a small molten pool.

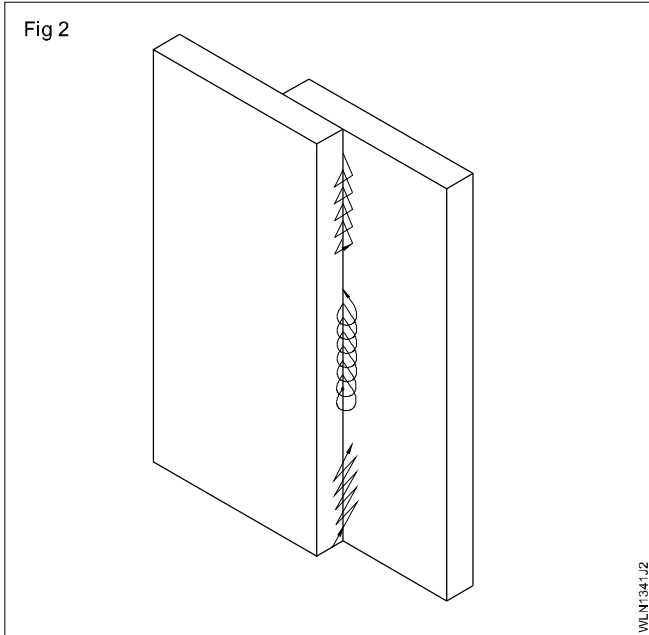
Use a short arc for depositing root run with whipping motion so as to prevent sagging of the weld metal. (Fig 1 and 2) Deposit the 2nd run with weaving motion and this will avoid sagging of the molten metal. The angle of the electrode should be  $75^{\circ}$  -  $80^{\circ}$ . (Fig 3)

Any one of the weaving motion shown in Fig 2 can be used.

**Do not break the arc while moving in the upward direction.**

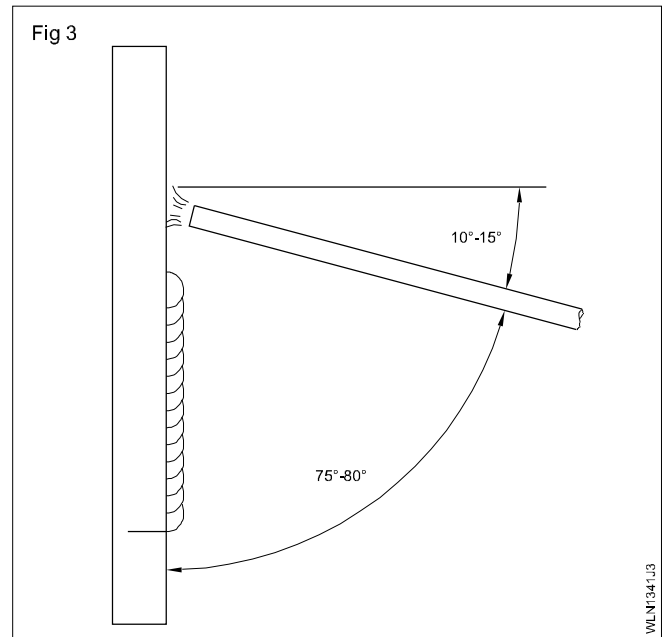
The motion of the electrode should be a weaving motion.





Keep the electrode motion confined to the weld width so that the edge of the upper plate is not melted off.

The rate of travel should be even for obtaining a uniform bead with a good appearance.

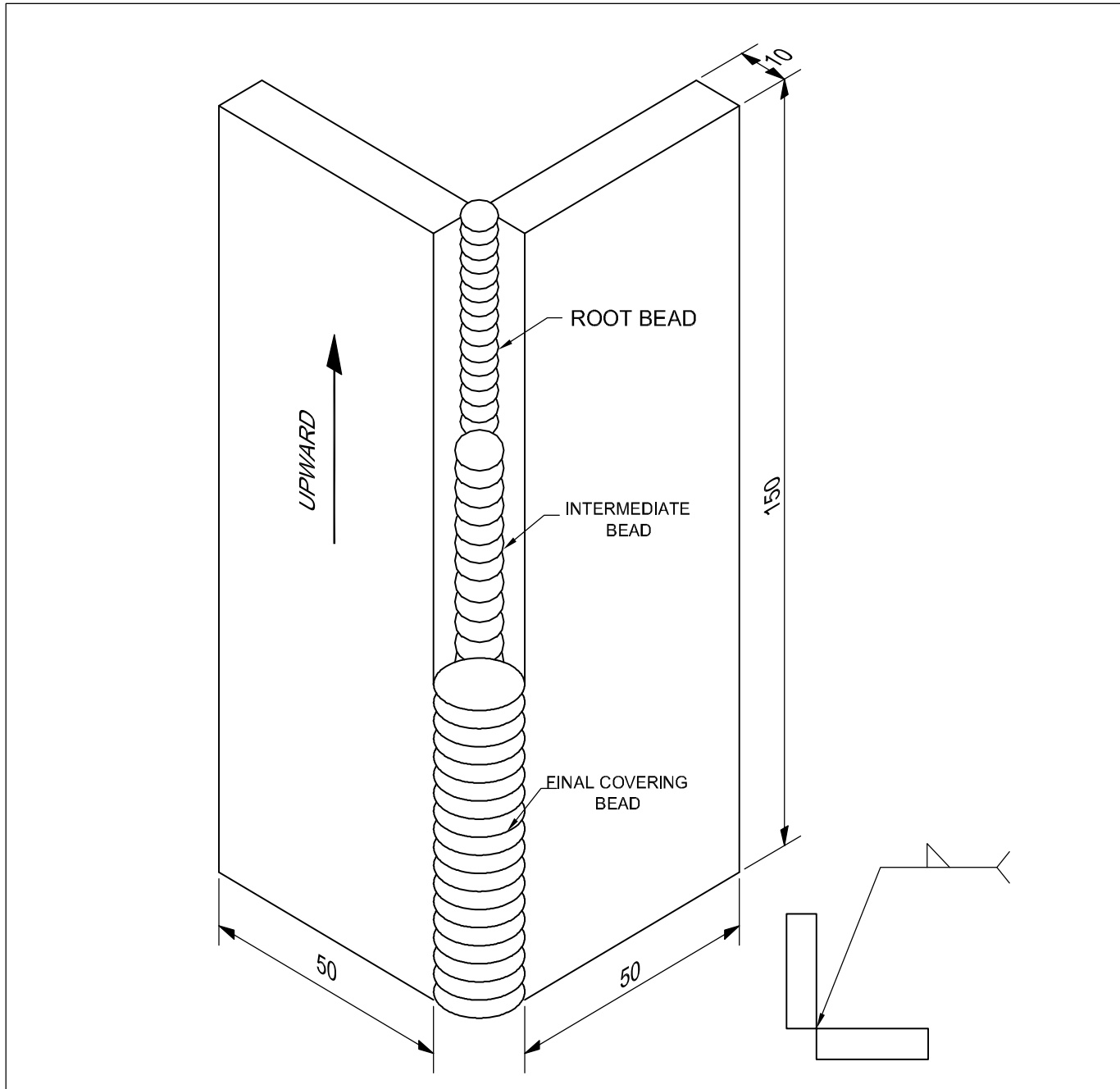


**Overlapping distance should not be more than 3 times the thickness of the base metal.**

**Open corner joint on MS plate 10mm thick in vertical position (3F)-(SMAW-15)**

**Objectives:** At the end of this exercise you shall be able to

- weld root run on open corner joint in vertical upward
- deposit 2nd and 3rd layer by weaving motion on open corner joint in vertical upward
- clean and inspect for surface defects and angle between the members.



2	50 ISF 10 - 150	-	Fe 310 - W	-	-	1.3.42
NO.OFF	STOCK SIZE	SEMI-PRODUCT	MATERIAL	PROJECT NO.	PART NO.	EX. NO.
SCALE NTS	<b>OPEN CORNER JOINT ON MS PLATE 10mm THICK IN VERTICAL POSITION (3F)-(SMAW-15)</b>				TOLERANCE ±1	TIME 10 Hrs
					CODE NO. WLN1342E1	

## Job Sequence

- Mark the plate to size and gas cut as per drawing.
- Prepare square edges and clean the parts to be welded.
- Set the 2 pieces as an open corner joint and use spacers to maintain a uniform root gap of 1.5 to 2mm. Then tack weld the two pieces together to form a 87° angle between the inner faces of the plates.
- Remove the spacers and set or fix the weldment in vertical position on the weld positioner.
- Select 3.15Ø electrode and set 110 Amps DCEP.
- Deposit root run with short arc length.

- Deslag and clean thoroughly with a wire brush.

### Use goggle while deslagging.

- Select 4mmØ electrode and set 160 amps.
- Deposit 2<sup>nd</sup> run using short arc and slight weaving motion.
- Deslag and deposit third and final run with 4mm dia. electrode.
- Avoid undercut.
- Clean the joint and inspect for defects.

## Skill Sequence

### Open corner joint on MS plate of 10mm thick in vertical position

**Objective:** This shall help you to

- **prepare and weld open corner joint on MS plate of 10mm thick in vertical position.**

#### Setting and tacking of the fillet open corner joint

Mark and punch the plates, to cut square by gas cutting.

Grind or file the gas-cut edges to square.

Remove the grinding burrs and clean the surfaces by filing and with a wire brush.

### Wear goggles while cutting, grinding.

Set the fillet open corner joint with a 1.5 to 2mm root gap and an angle of 87° between the inside surfaces of the plates to control the distortion. Fig1.

Tack-weld on the root side of the joint on both ends.

Use a 3.15 mm dia. M.S. electrode and 110 amps current.

Position the joint in vertical and the angle of the line of weld with the top of the table should be 90°. (Fig 1)

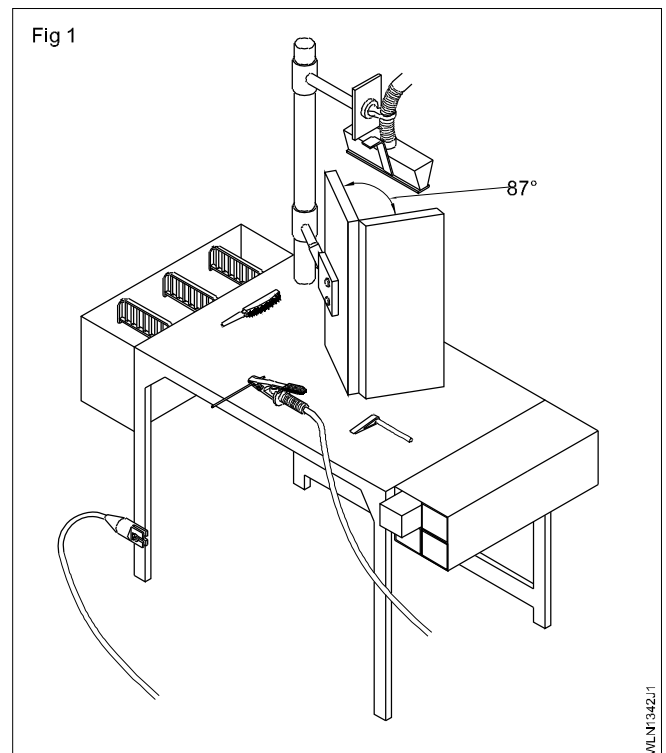
#### Welding fillet open corner joint in vertical position

Deposit root run with a 3.15 mm dia. electrode and 110 amps welding current. (Fig 2)

Maintain an electrode angle of 80° to the line of weld and the electrode movement slightly sideways, and deposit weld bead from the bottom to the top. Give whipping motion to the electrode.

Maintain a short arc to get uniform fusion and a keyhole to ensure proper root penetration.

Keep 1.6 mm root penetration depth.

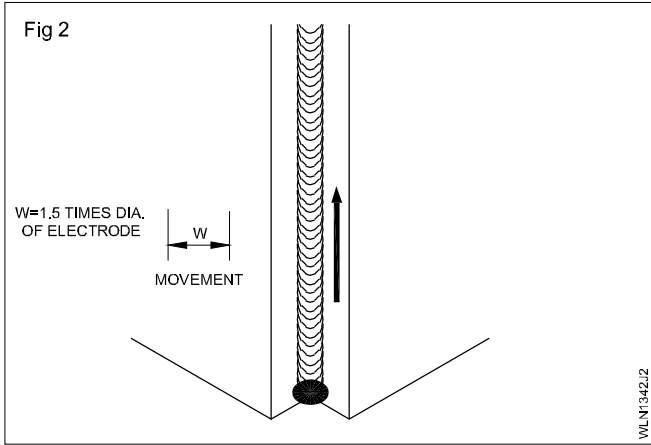


Deslag and clean the root bead at the toes thoroughly; also Deslag and clean the weld bead.

### Wear safety goggles.

Deposit the second run with a 4 mm dia. electrode and 160 amps welding current. The angle of electrode should be 80° to the line of weld and the arc length should be short.

Move the electrode steadily upwards and sideways as done in exercise No.

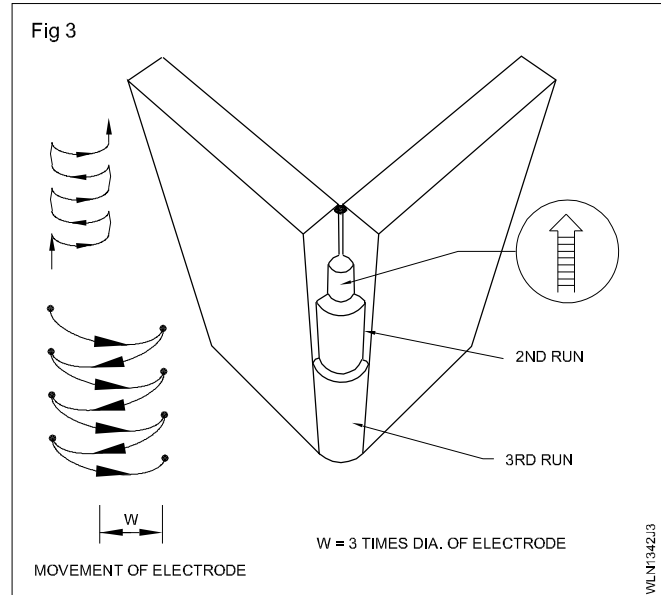


Deslag and clean the weld bead.

Deposit the third and final run with a 4 mm dia. electrode and 160 amps welding current with short arc length and sideways movement. (Fig 3)

Deslag and clean the weld bead.

**Avoid over-reinforcement height and edge burning.**



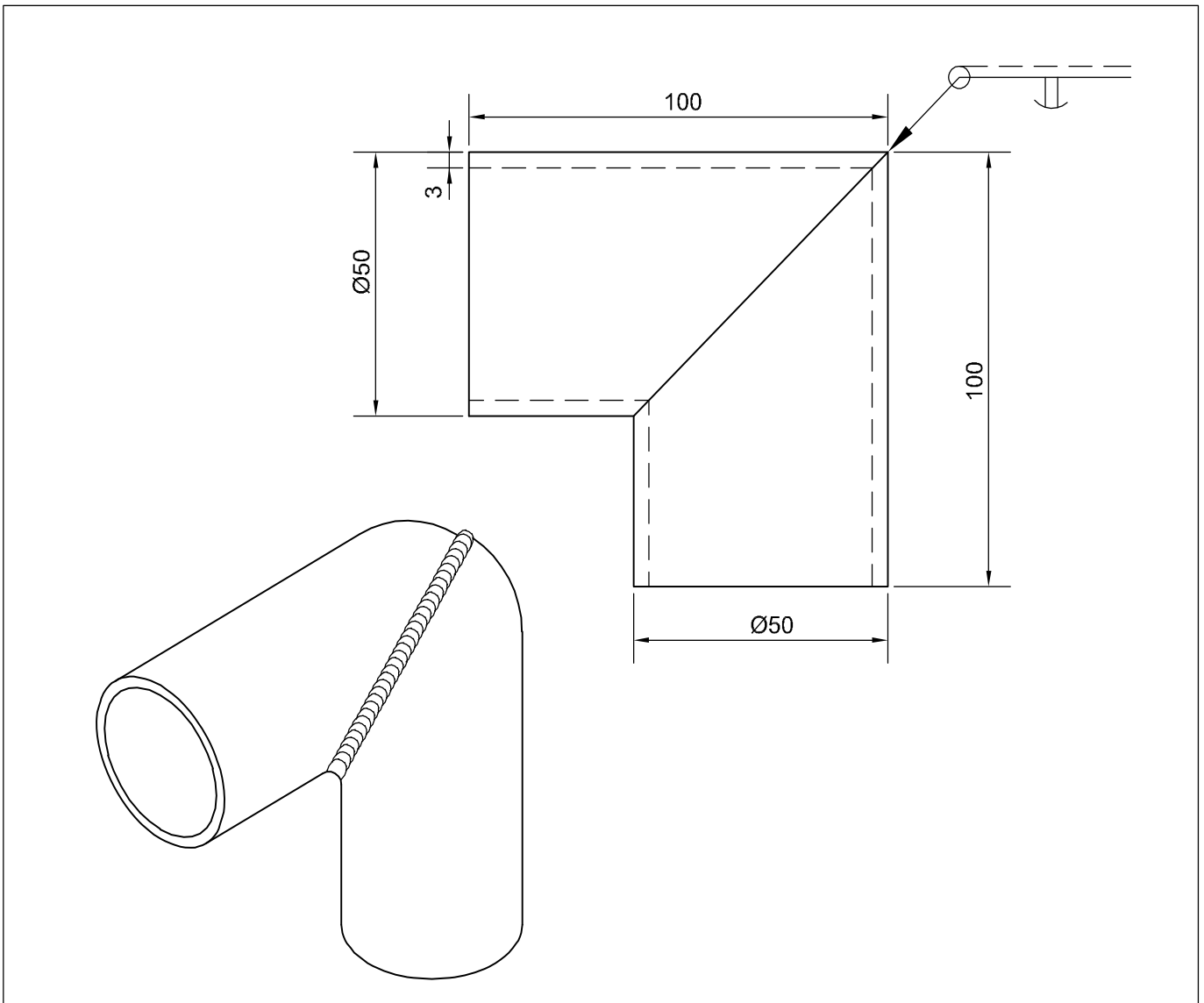
Inspect the open corner fillet weld for:

- external weld defects
- edge burning and reinforcement height
- depth of root penetration.

**Pipe welding - Elbow joint on MS pipe  $\varnothing 50\text{mm}$  and 3mm wall thickness in flat position (1G)-(OAW-14)**

**Objectives:** At the end of this exercise you shall be able to

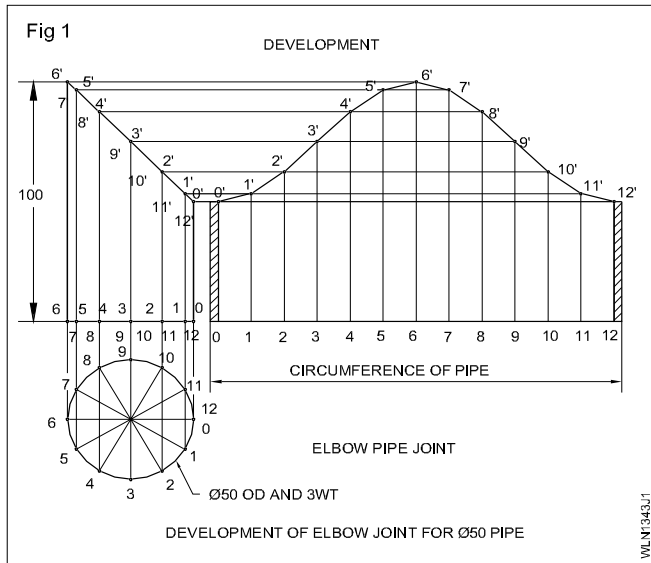
- draw the development for "ELBOW" pipe joint
- cut and prepare the pipe as per the dimensions
- clean the oxides and burrs from the welding surfaces
- set the pipes to form a  $90^\circ$  pipe elbow joint
- tack weld the pipe with a root gap of 1.6mm
- start the weld and complete it in two halves
- clean and inspect for weld defects.



2	$\varnothing 50 \times 3 - 100$	-	Fe 310 - W	-	-	1.3.43
NO.OFF	STOCK SIZE	SEMI-PRODUCT	MATERIAL	PROJECT NO.	PART NO.	EX. NO.
SCALE NTS		<b>PIPE WELDING - ELBOW JOINT ON MS PIPE  <math>\varnothing 50\text{mm}</math> AND 3mm WALL THICKNESS IN  FLAT POSITION (1G)-(OAW-14)</b>			TOLERANCE	TIME 15 Hrs
					CODE NO. WLN1343E1	

## Job Sequence

- Ensure the correct size of the pipes are used.
- Draw development for an "elbow" joint. Fig 1 on a drawing sheet scale full size.



- Cut the development of the pipe elbow from the drawing sheet and paste it on one end of both the 100mm long pipes.
- Make punch marks along the profile of the development on the pipes and cut the pipe along the punch marks using a hacksaw.
- Deburr the cut edges and file it to correct any irregularity on the cut edges.
- Clean the surface of the pipe of any oxide and other contaminants.
- Set and align the pipe to on angle of 90°.
- Select nozzle No. 7 and  $\varnothing 3\text{mm}$  CCMS filler rod with  $0.15 \text{ kg/cm}^2$  pressure for both gases.
- Set neutral flame.

## Skill Sequence

### (ELBOW) Joint on MS pipe $\varnothing 50 \times 3\text{mm}$ wall thickness in flat position

**Objective:** This shall help you to

- prepare and weld (ELBOW) joint on MS pipe  $\varnothing 50 \times 3\text{mm}$  wall thickness in flat position.

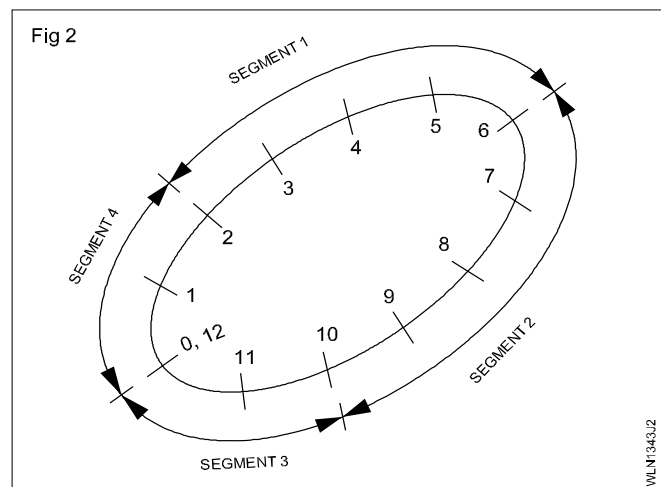
Fix no. 7 nozzle to the blowpipe to help in fusing both the edges of the joint (which is 3mm thick) to the full depth and get good root penetration.

Also the joint which is elliptical in shape can be welded properly with good fusion and root penetration only if the tack welded pipes are welded in 4 segments.

The segments are divided on the tacked pipe elbow joint as shown in Fig 2 under job sequence.

This division into 4 segments will help to keep the job in the required position so that the welding is done partially by vertical welding technique and partially by flat position.

- Follow necessary safety precautions.
- Tack weld the joints at 4 places with 1.6mm root gap and keep the joint in alignment. Check the 90° angle between the pipe axes using try square.
- Use leftward and vertical welding technique.
- Weld the joints by manipulating the blowpipe and filler rod in one run using  $3\text{mm} \varnothing$  CCMS rod dividing the weld into 4 segments.
- The joint which will be in the form of an ellipse has to be welded in 4 segments. Fig 2 The order of sequence of welding is 2 to 6 (segment 1), 10 to 12 (segment 3), 10 to 6 (segment 2) and 2 to 0 (segment 4). This order of welding sequence will help to keep the tacked joint such that the welding is partially done in vertically upwards and partially in flat position.



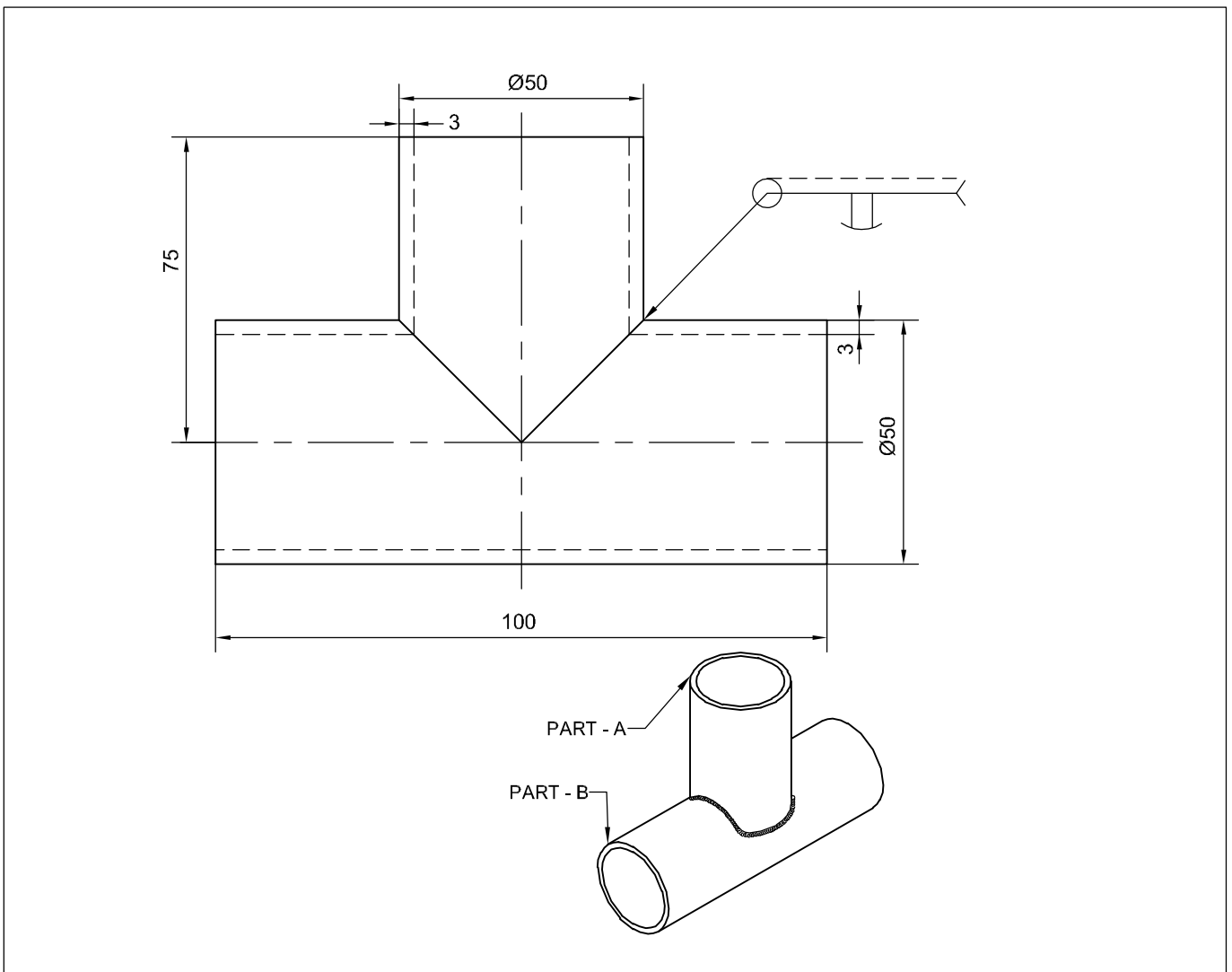
- Ensure maintaining keyhole and ending the weld of each segment properly to get the root penetration without fail.
- Avoid excessive penetration.
- Clean the welded joint and inspect for weld defects.



**Pipe welding 'T' joint on MS pipe  $\varnothing 50\text{mm}$  and 3mm wall thickness in flat position (1G) - (OAW-15)**

**Objectives:** At the end of this exercise you shall be able to

- draw the development for 90° T branch
- cut and prepare the pipes as per dimensions
- set 90° angle of the branch pipe using try square
- tack weld the pipe and recheck the angle
- start and complete the weld in two halves
- manipulate the blowpipe and filler rod holding them at the required angles during welding
- clean and inspect for external weld defects.



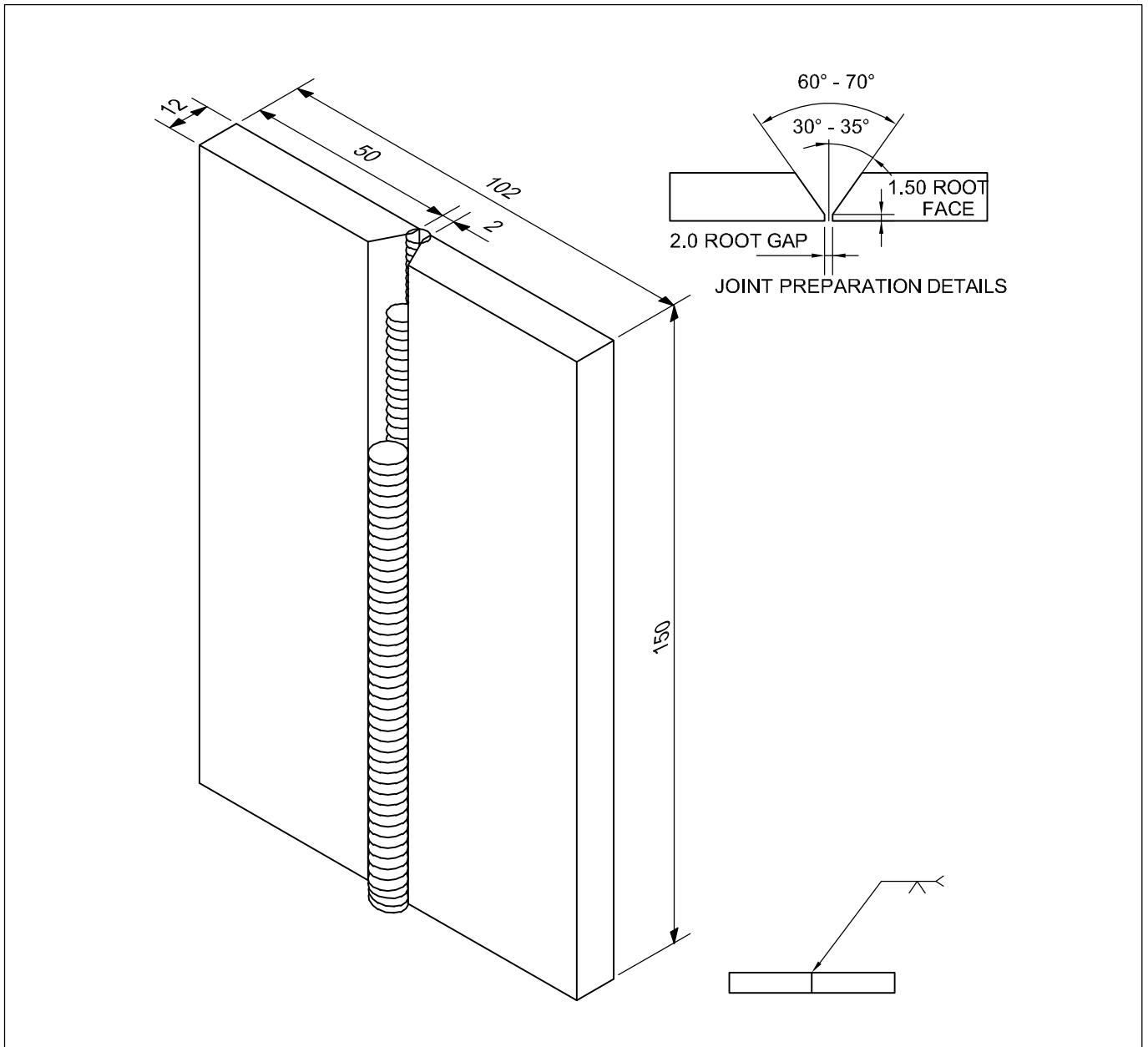
1	$\varnothing 50 \times 3 - 100$	-	Fe 310 - W	-	B	1.3.44
1	$\varnothing 50 \times 3 - 75$	-	Fe 310 - W	-	A	1.3.44
NO.OFF	STOCK SIZE	SEMI-PRODUCT	MATERIAL	PROJECT NO.	PART NO.	EX. NO.
SCALE NTS		<b>PIPE WELDING - 'T' JOINT ON MS PIPE  <math>\varnothing 50\text{mm}</math> AND 3mm WALL THICKNESS IN                      FLAT POSITION (1G)-(OAW-15)</b>			TOLERANCE $\pm 1$	TIME 10 Hrs
					CODE NO. WLN1344E1	



**Single "V" butt joint on MS plate 12mm thick in vertical position (3G)-(SMAW-16)**

**Objectives:** At the end of this exercise you shall be able to

- set and tack-weld single 'V' butt joint
- deposit root run ensuring root penetration in vertical position
- deposit the second and third runs with a weaving movement of electrodes and without weld defects.



2	50 ISF 12 x 150	-	Fe 310 - W	-	-	1.3.45
NO.OFF	STOCK SIZE	SEMI-PRODUCT	MATERIAL	PROJECT NO.	PART NO.	EX. NO.
SCALE NTS	<b>SINGLE "V" BUTT JOINT ON MS PLATE 12mm THICK IN VERTICAL POSITION (3G)-(SMAW-16)</b>				TOLERANCE ±1	TIME 15 Hrs
					CODE NO. WLN1345E1	

## Job Sequence

- Cut the MS plate 12mm thick to size (2 Nos.).
- Bevel the edges as per drawing.
- Both plates will have 30 to 35° bevel angle and 1.5mm root face and with no burr at the edges.
- Using spacers maintain a uniform gap of 2mm throughout and tack weld the plates.
- Preset the plates to 177° on the root side of the joint.
- Set the tack welded joint in vertical position
- Use  $\varnothing 3.15$ mm MS electrode and DCEN polarity for DC welding.

- Deposit the root run starting from bottom of the plate upward and maintain a uniform root penetration.
- Use short arc.
- Remove slag etc. and clean the weld with wire brush.
- Use  $\varnothing 4$ mm MS electrode and 150-amp current.
- Deposit 2<sup>nd</sup>, 3<sup>rd</sup> run using proper weaving technique and complete the weld in vertical position.
- Check the proper root penetration and other external weld defects.
- Rectify the defects whenever possible.

## Skill Sequence

### Single 'V' butt joint on MS plate of 10mm thick in vertical position

**Objective:** This shall help you to

- **prepare and weld single 'V' butt joint on MS plate of 10mm thick in vertical position.**

#### Preparation of pieces

Cut and bevel the edges to an angle of 30 to 35° by using oxy-acetylene cutting.

Grind the bevel edges to remove oxides, and get smoothness.

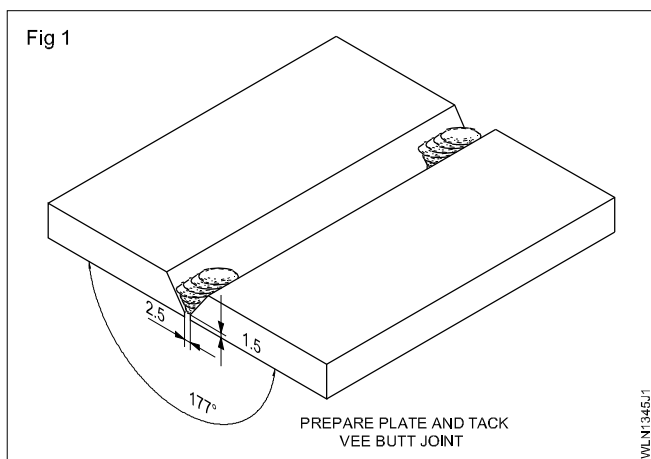
**Use goggles while cutting and grinding.**

Prepare a 1.5mm root face throughout the length by filing.

#### Setting and tacking of single 'V' butt joint

Keep the bevel edges parallel with the 2.5mm root gap. The 2.5mm thick spacers are used to get a uniform and parallel root gap.

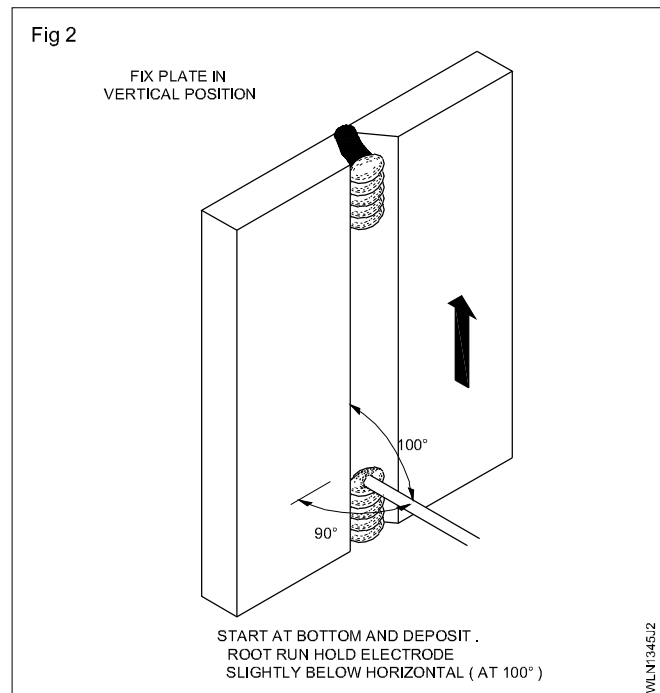
Tack-weld on both ends with correct alignment and presetting of 3° to control distortion. (Fig 1) i.e. on the root side the angle between the plates should be 177°.



Position the joint in vertical using the weld positioner.

#### Deposition of weld beads

Deposit the root run using a 3.15 mm dia. M.S. electrode and 110 amps current with a slight sideways movement of the electrode. (Fig 2)



**Ensure a keyhole throughout the root run.**

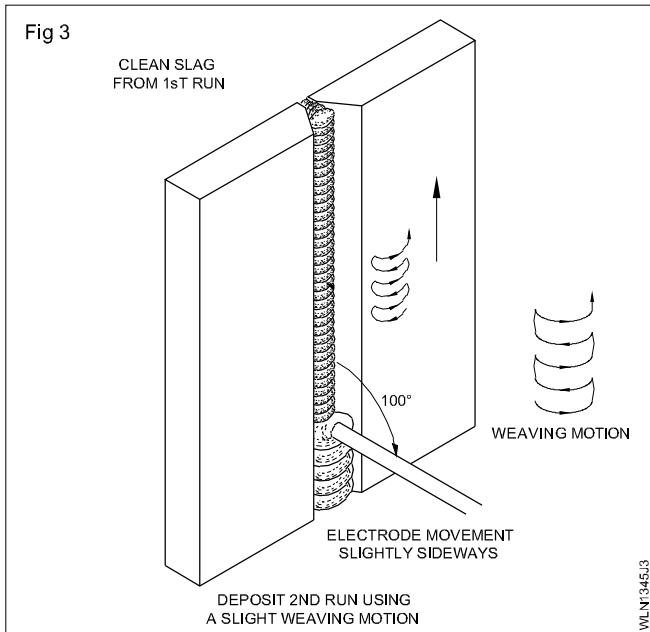
The angle of the electrode in the holder should be 120° so that it is convenient to hold the electrode at 80° to the line of weld.

The arc length should be short.

**The root penetration depth should not exceed 1.6 mm.**

Remove the slag and clean the root run by using a chipping hammer and wire brush.

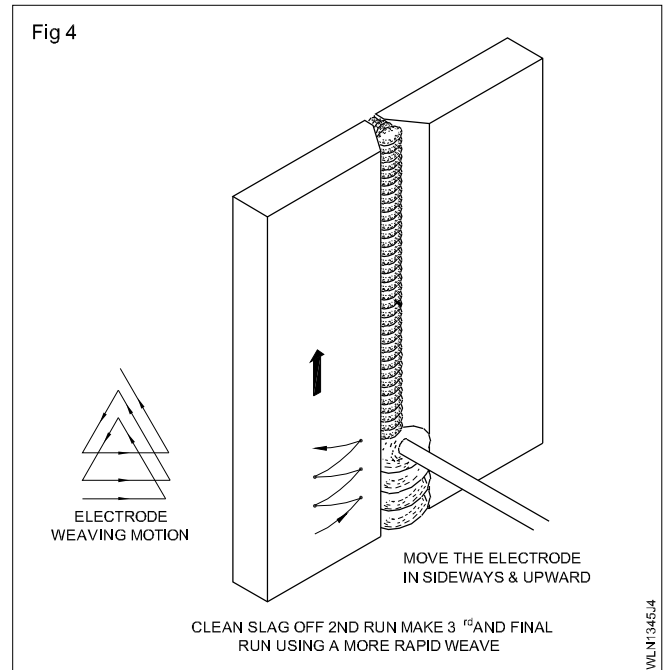
Deposit the second run using a 4 mm dia. M.S. electrode over the root layer with 160 amps current and an electrode movement slightly sideways. (Fig 3)



Remove the slag and clean the weld bead thoroughly.

Deposit the third layer using a 4 mm dia. M.S. electrode and 160 amps current (Fig 4) pausing regularly at the toes of the weld.

Fig 4



The weaving motion of electrodes can be anyone of the three patterns shown in Fig 3 and Fig 4.

The arc length should be short which helps to control sagging of weld metal.

**Avoid undercut and excessive convexity, concavity.**

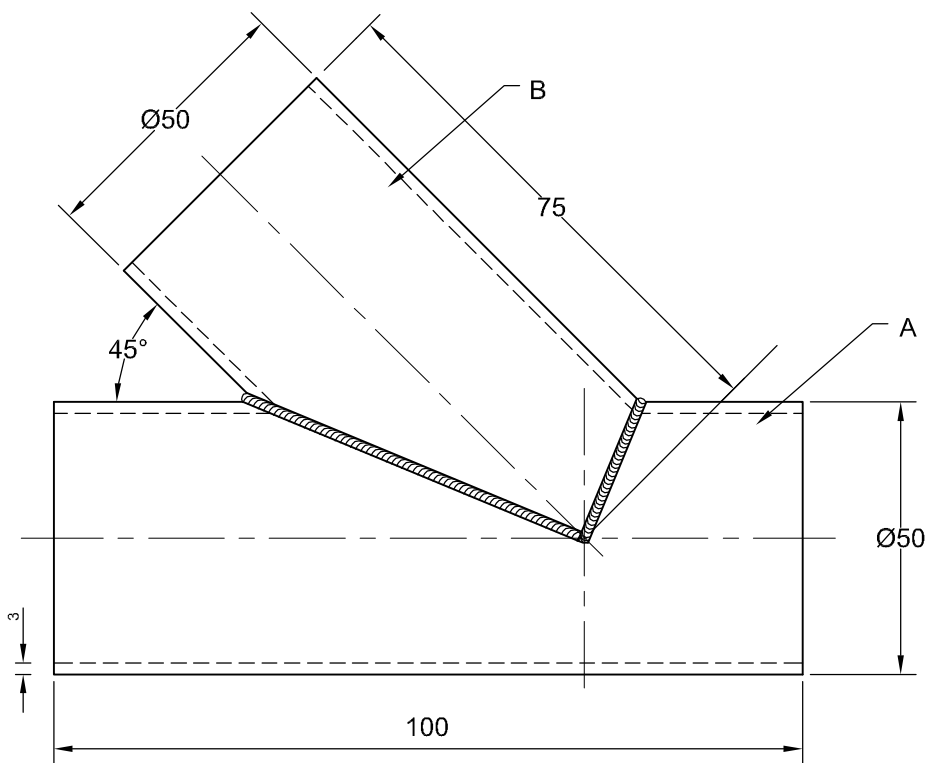
Remove slags with a chipping hammer and clean the weld bead thoroughly with a wire brush.

Inspect for root penetration, undercut, blow holes and excess reinforcement.

Pipe welding 45° angle joint on M.S. pipe Ø50mm and 3mm wall thickness (1G)-(OAW-16)

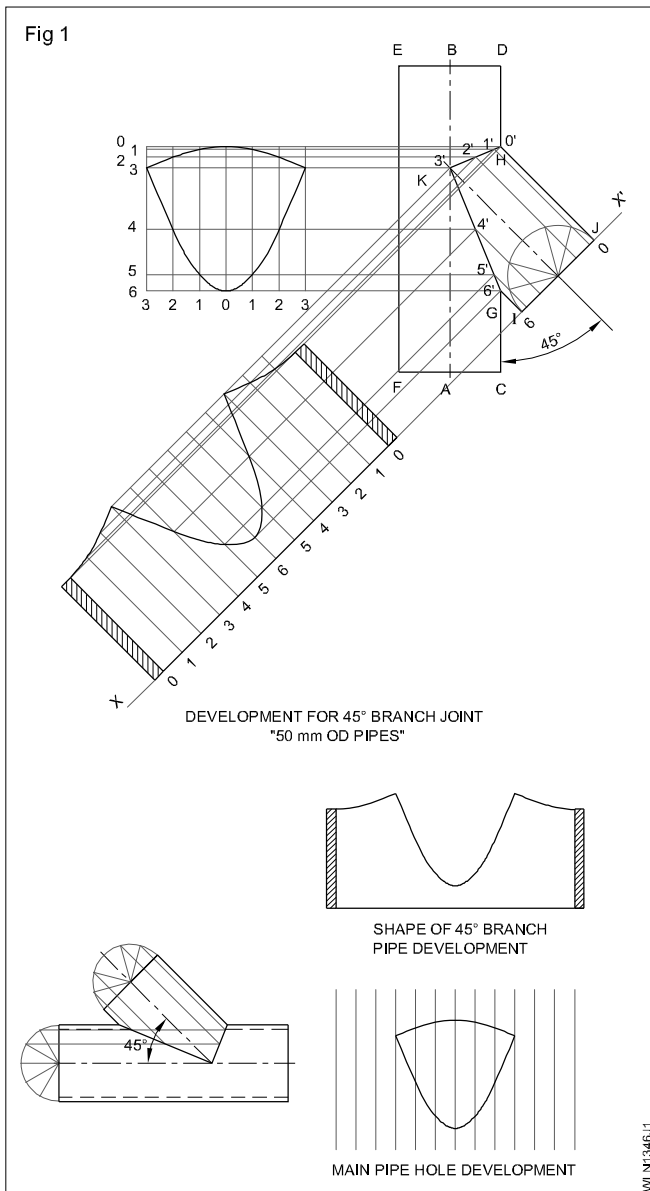
Objectives: At the end of this exercise you shall be able to

- prepare the development of pipe for 45° branch joint
- cut and prepare the pipes as per dimensions
- tack and complete the welding by manipulating the torch and filler rod.



2	-	-	Fe310 - W	-	A	1.3.46
1	Ø 50 x 3 - 75	-	Fe310 - W	-	B	1.3.46
NO.OFF	STOCK SIZE	SEMI-PRODUCT	MATERIAL	PROJECT NO.	PART NO.	EX. NO.
SCALE NTS	<b>PIPE WELDING 45° ANGLE JOINT ON M.S. PIPE Ø50mm AND 3mm WALL THICKNESS (1G)-(OAW-16)</b>				TOLERANCE ±1	TIME 15 Hrs
					CODE NO. WLN1346E1	

**Procedure for development of 45° branch pipe:** Refer Fig 1. Draw a center line AB.



Mark the points C, D, E and F taking the radius and the length of the given pipe with the center line AB as reference line.

On the line "CD" locate the position of the 45° branch pipe. This will be "G".

Draw a 45° angle at the point "G".

## Job Sequence

- Ensure the correct size of pipes are used.
- Prepare development for 45° branch on a drawing sheet.
- Cut and paste it on the pipes.
- Punch mark the profile of the development on both pipes. Cut the branch pipe along the punch marked profile and file it. Cut the profile marked on the main pipe by gas cutting and file it.

Choose a suitable height and mark the height of the branch pipe (GI) in 45° line from point G.

From I, draw a horizontal line on both sides (XX'). This XX' will be the base line for drawing development.

From I, plot the outside diameter of the branch pipe IJ on the line XX'.

Draw a center line for the branch pipe. This line will cut the main pipe's center line AB at K.

Join GK. Draw a perpendicular line to GK at K which meets CD at H. Join KH. Now IGKHJ will be the shape (outline) of the branch pipe.

Draw a semicircle equal to the branch pipe outside diameter.

Divide the semicircle into 6 equal parts as 0-1; 1-2; 2-3; 3-4; 4-5 & 5-6.

Draw vertical lines from these points 1,2,3,4,5. Already there will be two vertical lines IG from the point 6 and JH from point 0. These vertical lines will cut the branch pipe lines 'GK' and 'KH' at points 6', 5', 4', 3', 2', 1' & 0'. Note that points 6' and G as well as points 0' and H are the same points. In the base line XX' plot 13 points equal to the distance of '0-1' as 0, 1,2,3,4,5,6,5,4,3,2,1,0.

Draw vertical lines to XX' from these 13 points.

Draw horizontal lines parallel to XX' from points 6', 5', 4', 3', 2', 1', 0'. These 7 horizontal lines will cut the 13 vertical lines from the base line at 13 points.

Join the 13 cutting points with a regular smooth curve. Now the required development for the 45° branch pipe will be ready. Give allowance of 3 to 5mm at the edges of the development. (Fig 1)

**For developing a hole in the base pipe:** Above the main pipe, draw 7 lines parallel to AB namely 3,2,1,0,1,2,3 equal to the distance of 0-1 on the semi circle.

Draw vertical lines from 0', 1', 2', 3', 4', 5', 6'. These vertical lines will intercept the 7 horizontal lines. Join the intercepting points with a smooth curve. The required development for hole is now ready.

- Deburr the gas cut edges and file the edges.
- Clean the surface of the pipe to remove any oxide and other contaminants.
- Set and align the branch pipe with the main pipe at an angle of 45°. (Fig 2)
- Select no. 7 nozzle, ø3mm CCMS rod and use neutral flame with 0.15 kg/cm<sup>2</sup> pressure for both gases.

- Follow necessary safety precautions.
- Tack-weld the joint at 4 place with 45° intervals and with a 2 mm root gap to ensure root penetration.
- Ensure the tacked pipe "Branch" joint is positioned properly to make it convenient to manipulate the blow pipe and filler rod without any obstruction.
- Weld the joint by manipulating the blow pipe and filler rod without rotation of the pipe.
- Maintain keyhole throughout the welding and give side to side motion to the blow pipe to ensure good root penetration and fusion of both the edges of the joint.
- Complete the weld in 4 sectors 1, 2, 3 and 4 along the curved joint using leftward technique.
- Take care to properly fuse the crater of the previous sector welded with the starting of the new sector.

**Avoid excess penetration.**

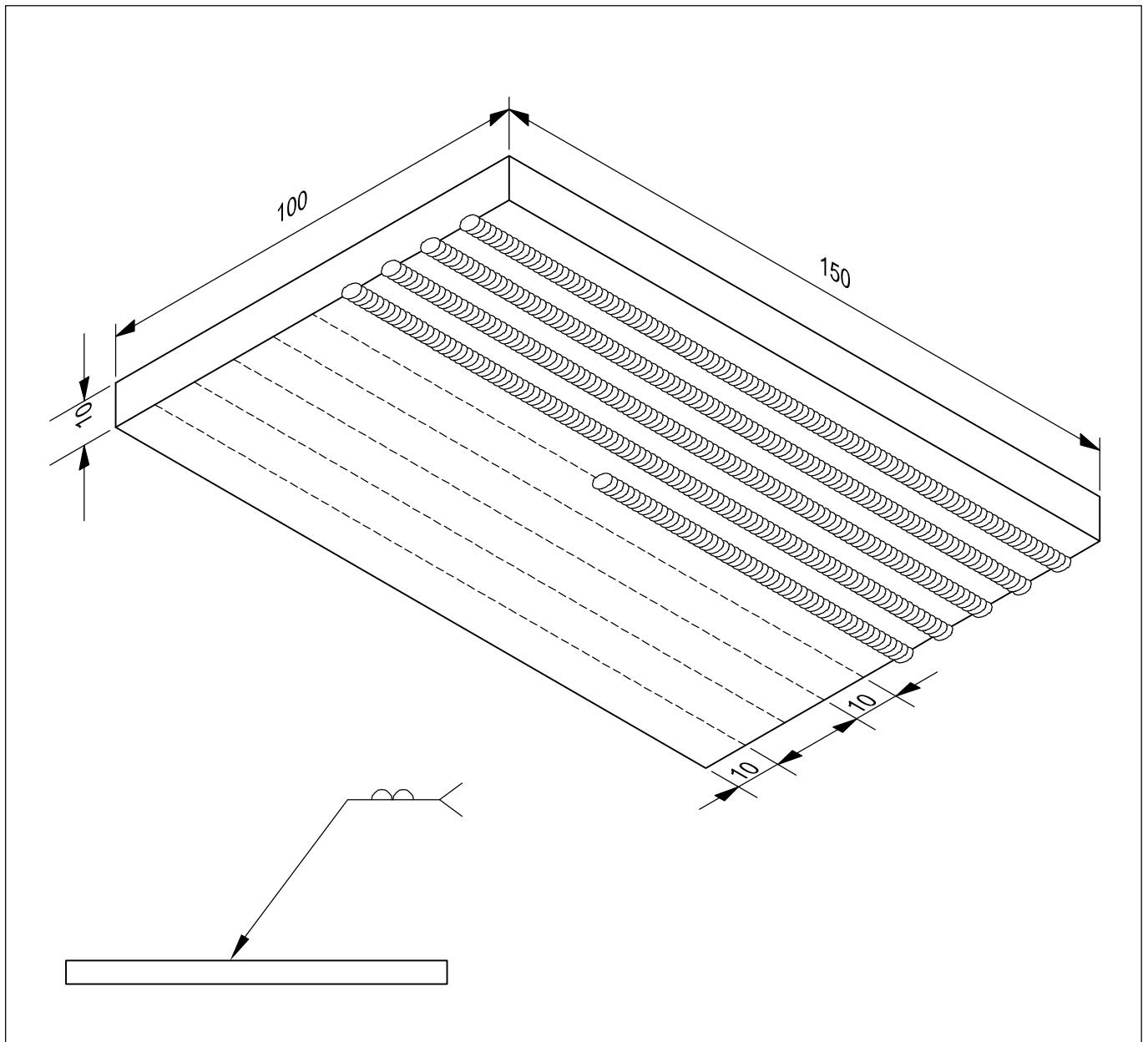
- Clean the weld and inspect the weldment for defects.



**Straight line beads on MS plate 10mm thick in over head position (SMAW-17)**

**Objectives:** At the end of this exercise you shall be able to

- set the M.S. plate in overhead position to lay straight line beads
- select the electrode, current polarity and arc length for overhead welding
- deposit uniform beads in straight line in overhead position and control the sagging of the molten metal and slag from the beads
- clean and inspect the straight line beads for surface defects.



1	150 ISF 10 - 100	-	Fe 310 - W	-	-	1.3.47
NO.OFF	STOCK SIZE	SEMI-PRODUCT	MATERIAL	PROJECT NO.	PART NO.	EX. NO.
SCALE NTS	<b>STRAIGHT LINE BEADS ON MS PLATE 10mm THICK IN OVER HEAD POSITION (SMAW-17)</b>				TOLERANCE ±1	TIME 10 Hrs
					CODE NO. WLN1347E1	

## Job Sequence

- Prepare and clean the plate.
- Lay out parallel lines as per drawing.
- Mark and punch lines with a center punch.
- Fix the plate in overhead position in the positioner. Adjust the job to suit your height.
- Select and fix a 3.15 mm dia. M.S. electrode and set 100-110 amperes current.

**Use a helmet specially when welding in overhead position.**

**Run and support the electrode-holder cable over your shoulder.**

**Use hand sleeves and leg guards in addition to other protective clothing.**

- Deposit the first bead along the punched line with short arc at normal speed.

**Control the molten pool and slag using proper technique.**

- Deslag, clean the bead and inspect for defects.
- Deposit the other beads along the punched line as done in the case of the first bead.
- Inspect the weld beads for defects.

Practice until you are able to deposit uniform straight beads without defects.

## Skill Sequence

### Straight line bead on MS plate 10mm thick in over head position

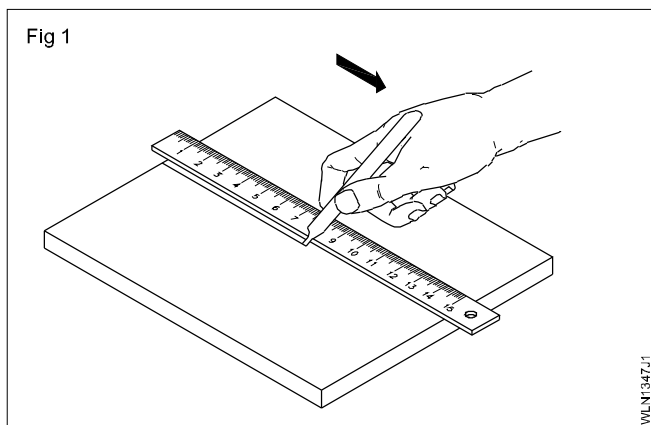
**Objective:** This shall help you to

- **prepare and practice straight line bead on MS plate 10mm thick in over head position.**

#### Introduction

Though overhead welding is the most difficult one, it can be made easy by following proper welding techniques. Welding in overhead position is done in piping work, ship building and in structural Capital Goods & Manufacturing.

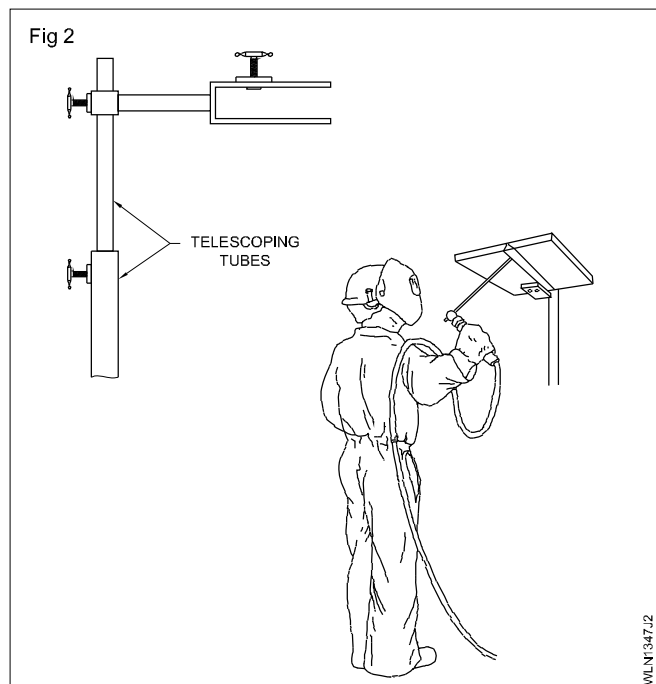
Mark parallel lines with a scribe (Fig 1) and punch the line with a center punch.



When setting the job in overhead position, the job with the punched line should be facing the ground. (Fig 2)

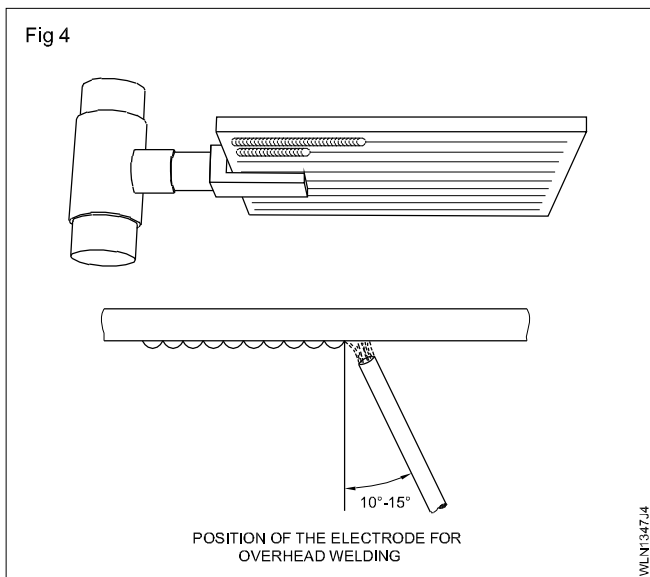
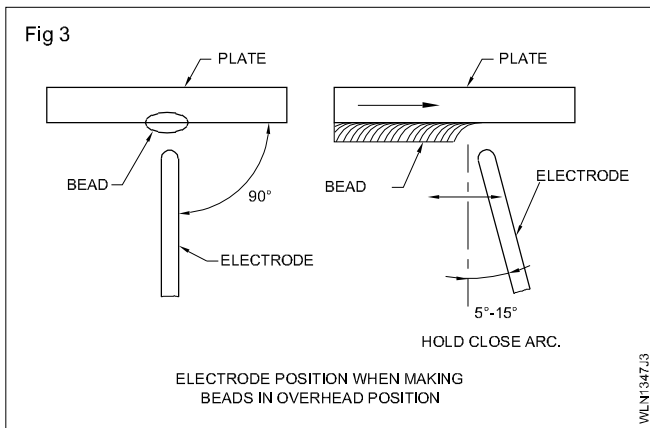
The height of the job is to be adjusted depending on your height using the telescoping tubes of the jig or positioner. (Fig 2) Small particles of molten metal and spatters will fall down from the joint during welding in overhead position and to protect yourself from these hot particles it is very important to use a helmet, hand sleeves, leg guards, gloves, apron and shoes.

In this position, the hand will be pulled down due to the weight of the cable. Due to this it is difficult to maintain a short arc constantly. This can be reduced by placing the cable over the shoulder as shown in Fig 2.



Use 3.15 mm  $\varnothing$  MS electrode and set 100 - 110 amperes current. The current is set around 10amp less than that used for flat position, because maintaining a small molten pool is very important to reduce the pulling effect of gravity.

The electrode should be held at 90° to the base metal surface and at 5° to 15° to the direction of the weld. (Figs 3 & 4)

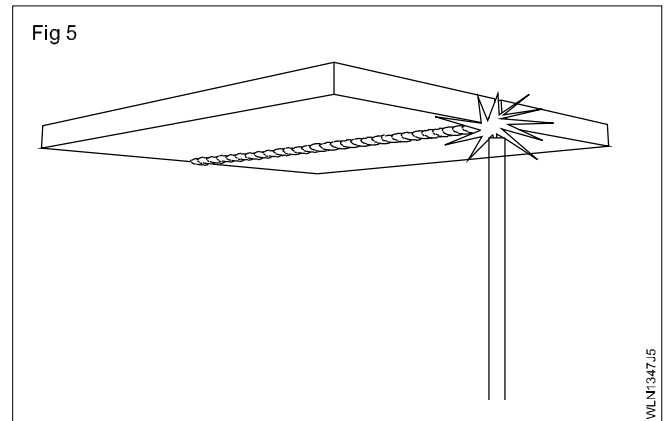


You can successfully overcome the force of gravity by using a short arc.

Deposit the first bead along the punched line. Care should be taken to maintain a very small molten pool to reduce the gravitational effect.

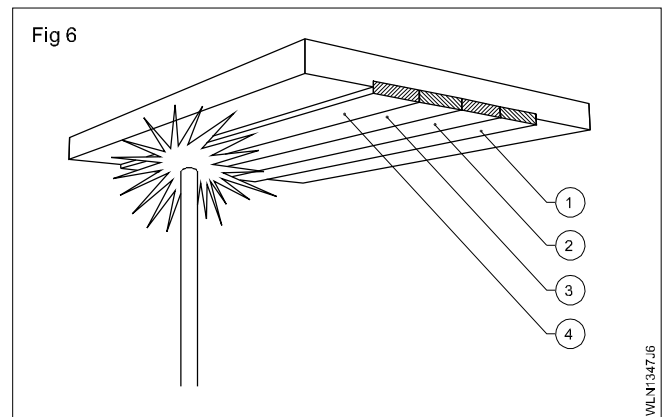
This will also help to control the molten slag from entering the molten metal.

Deposit the run up to the end of the work piece. (Fig 5)



Repeat the same procedure to weld the second and subsequent beads. (Fig 6)

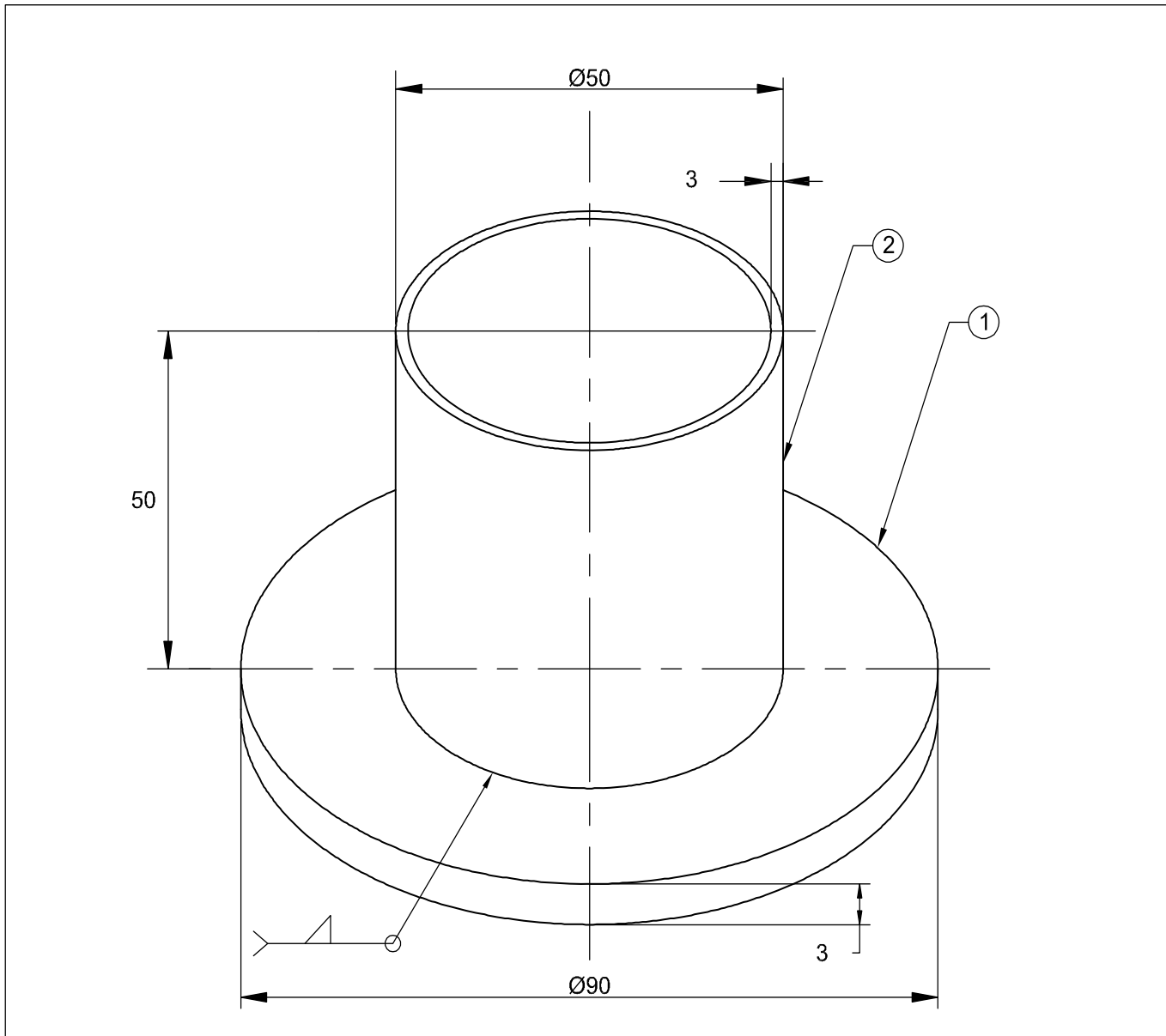
Inspect the weld for surface defects like uniformity of beads, undercuts, slag inclusions, blow holes etc.



Pipe flange joint on MS plate with MS pipe  $\varnothing 50\text{mm} \times 3\text{mm}$  wall thickness (1F) (SMAW-18)

Objectives: At the end of this exercise you shall be able to

- mark an internal and external circle on a square plate
- cut the internal and the external circles by oxy-acetylene gas cutting
- insert an MS pipe into the internal circle cut by gas and tack weld to form a pipe flange joint
- weld the pipe with the flange by arc in 1G position (rolling) in one run
- clean the joint and inspect for any external weld defect, proper bead profile and perpendicularly.



1	$\varnothing 50 \times 3 - 50$	-	Fe 310 - W	-	2	1.3.48
1	100 ISF 3 - 100	-	Fe 310 - W	-	1	1.3.48
NO.OFF	STOCK SIZE	SEMI-PRODUCT	MATERIAL	PROJECT NO.	PART NO.	EX. NO.
SCALE NTS	<b>PIPE FLANGE JOINT ON MS PLATE WITH MS  PIPE <math>\varnothing 50\text{mm} \times 3\text{mm}</math> WALL THICKNESS  (iF)-(SMAW-18)</b>				TOLERANCE $\pm 1$	TIME 15 Hrs
					WLN1348E1	

## Job Sequence

- Find the center of the given 3mm thick square plate by joining the 2 diagonals of the square plate using a scribe and mark a dot on the meeting joint of the diagonals using a dot punch.
- Using a spring divider scribe/draw a circle of radius 25mm at the center of the square plate and another larger circle with a radius of 45mm and punch mark both the circumference of the circles.
- Select 0.8mm size cutting nozzle and fit it with the cutting torch.
- Set a pressure of 0.15 kg/cm<sup>2</sup> for acetylene gas and 1.5 kg/cm<sup>2</sup> for oxygen gas for cutting 6mm MS plate.
- Set neutral flame and preheat at the center point of one of the edges of the square plate until it reaches bright red hot condition/kindling temperature.
- Press the oxygen cutting lever and move the torch by hand from the edge of the plate until the punch marked circumference of the larger circle is reached.
- Now using a roller guide and circle cutting attachment start cutting the larger external circle of 90mm diameter.

**Ensure necessary safety precautions to be used for gas cutting is followed.**

- To cut the internal circle, first pierce a small hole at about 10mm inside the circumference of the 50mm dia. circle.
- Move the torch towards the circumference from the pierced hole and complete the 50mm $\varnothing$  hole cutting using a small circle cutting attachment.

- Clean the cut edges and trim the inside face of the cut edges using a half round file.
- Insert the given pipe of 50mm outside diameter in the cut hole of the plate such that the end of the pipe is flush with the flat surface on the other side of the 6mm plate to form a pipe flange joint.
- Select a 3.15mm medium coated MS electrode and set 110 amperes current and DCEN if a DC welding is used.
- Tack weld at four places at 90° intervals on the other side of the joint.

**Ensure that the pipe is at 90° to the plate surface while tacking.**

- Change the electrode to 4mm dia. medium coated MS electrode and set 160 ampere current.
- Position the joint on a suitable weld fixture so that welding can be done by 1G rolling method.
- Complete the welding of the joint in one run using segment welding method.
- Deslag and clean the joint with a wire brush.
- Inspect visually for any external weld defects.

**Ensure proper crater filling at the end of each segment welding.**

**Use appropriate safety precaution during arc welding and deslagging.**

## Skill Sequence

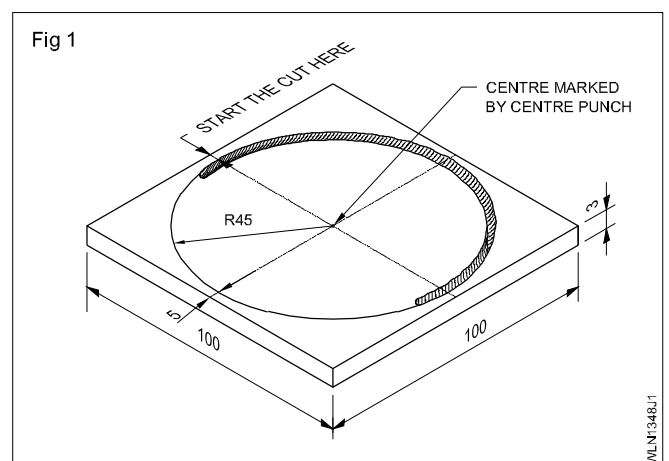
### Pipe flange joint on MS pipe in flat position

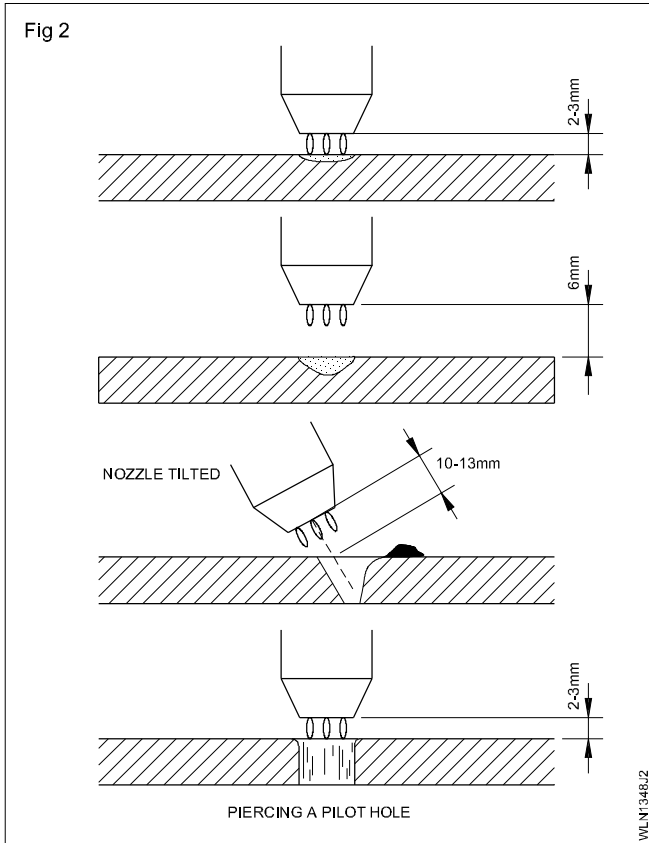
**Objective:** This shall help you to

- **weld pipe flange joint on MS plate with MS pipe  $\varnothing$ 50 mm x 3mm wall thickness.**

For external circle cutting to get a 90mm dia. circular plate from the given 100mm square plate, the cut can be started from the free edge of the plate Fig 1. After the cut reaches the punch marked circumference line, fix the circle cutting attachment (Fig 4) at a distance of 45mm from the center of the cutting nozzle and keeping the conical point of the circle cutting attachment at the center of the plate and cut the external circle of radius 45mm.

To cut an internal circle, a small hole called pilot hole is to be drilled or pierced by gas cutting inside the circumference of the circle/profile before starting to cut the required circle/profile. The procedure to pierce a pilot hole is as follows. Refer Fig 2.

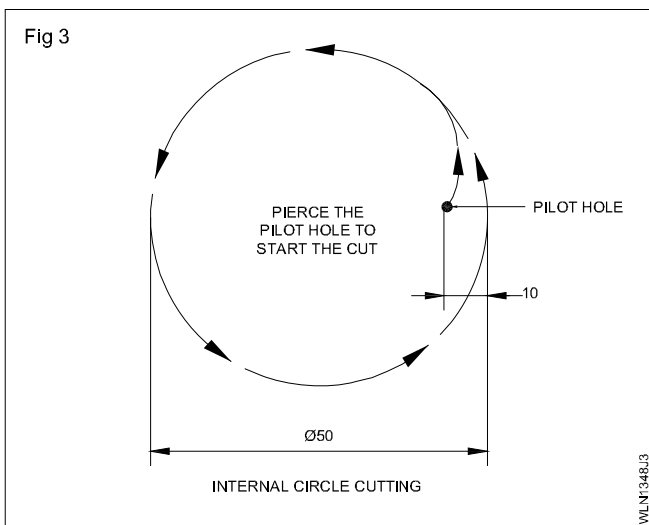




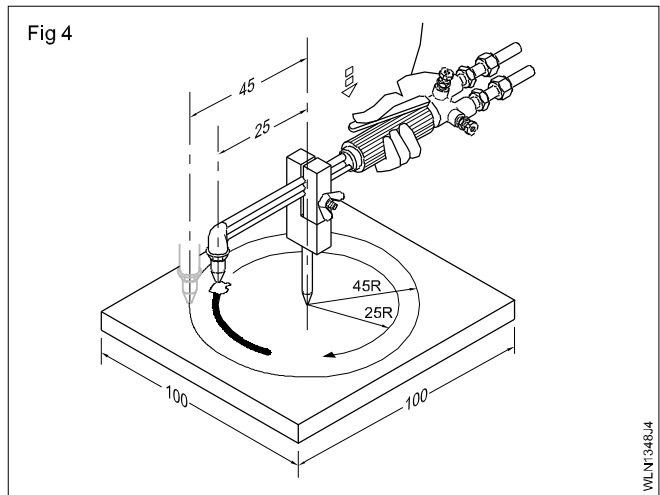
Set the flame in the usual manner then:

- Preheat the spot with the torch about 6mm from the plate, so that inner cones almost touch the plate.
- When the spot is bright red, lift the torch to about 13mm above the plate until the metal nearly melts and tilt the torch to the side a little.
- Press the cutting oxygen lever slowly and move the torch around slightly until the cut is through the plate.

After piercing the pilot hole move the torch as shown in Fig 3 until it reaches the circumference of the 50mm circle.

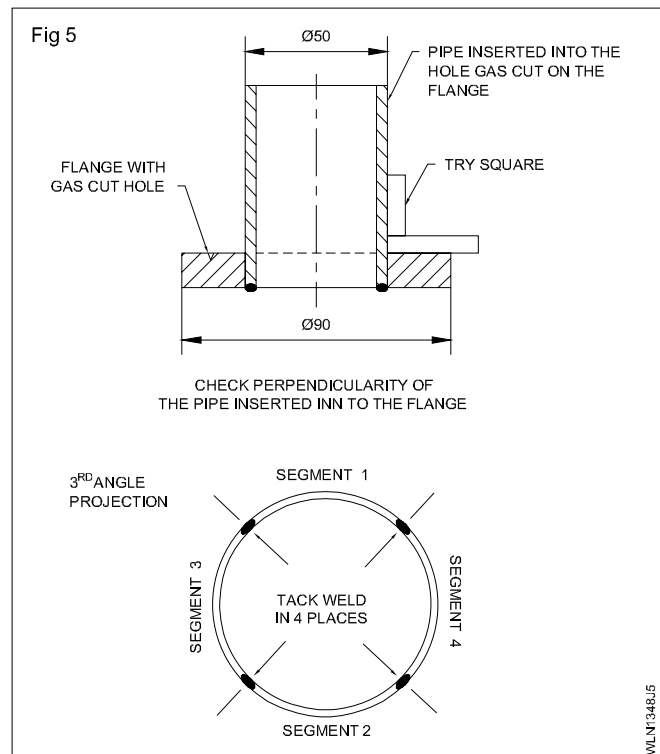


To cut a circle, it can be done by free hand movement along the circumference or a circle cutting attachment as shown in Fig 4 can be used which will give an accurate cut surface very close to 50mm diameter. To get a fine and uniform cut surface the torch has to be moved steadily with a uniform speed along the circumference.



While tacking the pipe with the gas cut flange ensure that perpendicularity is maintained. Refer Fig 5 Tacking is done at 4 places on the other side of the flange joint. Fig 5. Use 4mm dia. electrode so that the required fillet size of 3 to 3.5mm can be maintained.

To weld the joint in 1G (rolling) position, use a weld fixture as shown in Fig 6 to make it convenient to weld in 1G position and complete the weld in 4 segments. 1, 2, 3 and 4 (Fig 5)



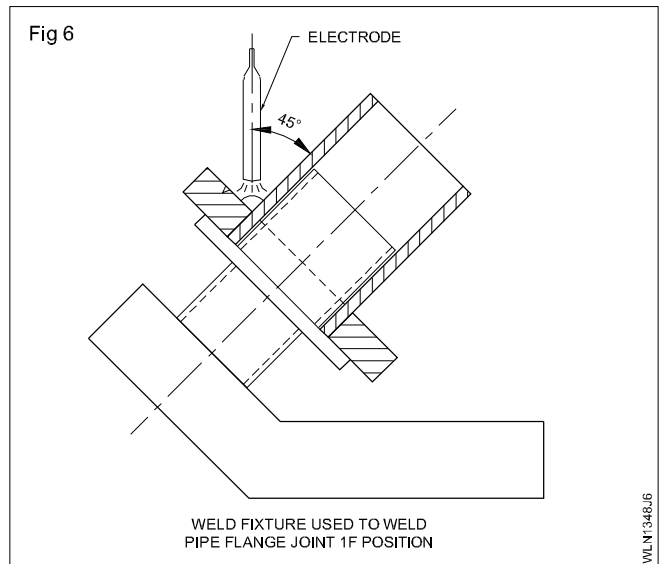
Maintain as short an arc as possible and an electrode angle of  $45^\circ$  between the plate and pipe surfaces.

Follow the weld sequence as shown in the Fig 5 which will help to control distortion i.e. First weld segment (1) in down hand position. Then rotate the joint by  $180^\circ$  and weld segment (2) in down hand position. Similarly, weld segment (3) and segment (4) by rotating the joint on the fixture to bring the segments for welding in down hand position. Fig 5.

While welding segments 3 and 4 the weld deposit should cover about 10mm distance over the previous deposit to ensure crater filling and continuity in the root penetration.

Deslag after welding each segment and avoid undercut by proper current setting and speed of welding.

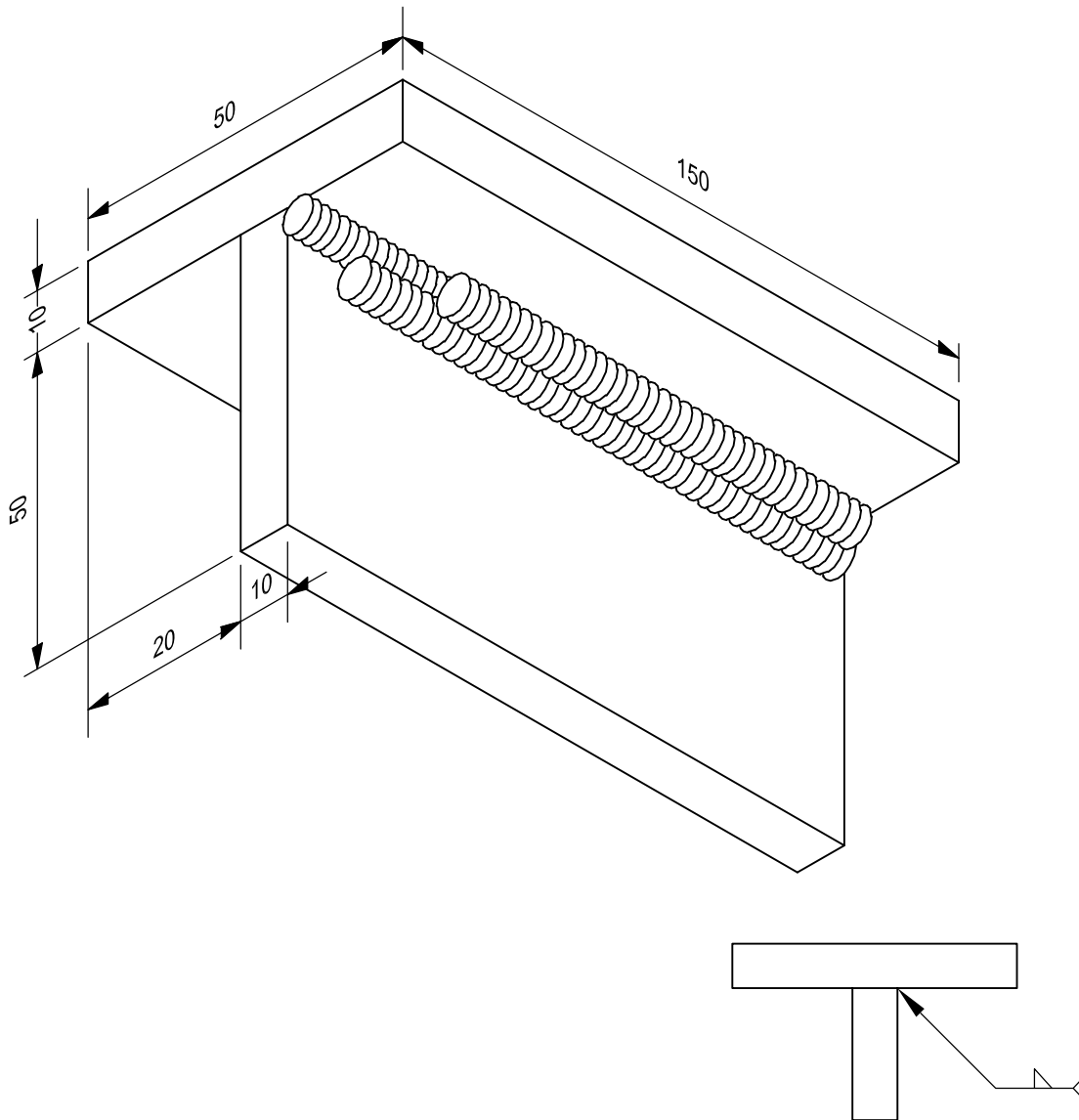
Clean the weld using wire brush. Check the fillet size with a weld gauge.



**Fillet - "T" joint on MS plate 10mm thick in over head position (4F)-(SMAW-19)**

**Objectives:** At the end of this exercise you shall be able to

- deposit root run on T fillet joint in overhead position
- control the molten pool when welding in OH position
- manipulate the electrode angle for a multi-run weld in OH position
- clean and inspect the weldment for surface defects.



2	150 ISF 10 - 50	-	Fe 310 - W	-	-	1.3.49
NO.OFF	STOCK SIZE	SEMI-PRODUCT	MATERIAL	PROJECT NO.	PART NO.	EX. NO.
SCALE NTS	<b>FILLET - "T" JOINT ON MS PLATE 10mm THICK IN OVER HEAD POSITION (4F)-(SMAW-19)</b>				TOLERANCE ±1	TIME 10 Hrs
					CODE NO. WLN1349E1	



## Job Sequence

- Prepare and clean the job pieces.
- Set and tack the job pieces at both ends of the Tee joint in flat positions.

**Tack the work pieces in outside edges so as to avoid starting defect.**

- Set the job in overhead position and adjust its height.

**Wear protective clothing i.e. helmet, hand sleeves, apron etc.**

- Set a current of 110 amps for a 3.15mmø M.S. electrode.

- Connect the electrode holder in positive pole in the case of a DC machine.
- Deposit root run (first bead) deep in the root of the joint using a 3.15 mm ø electrode.
- Remove the slag and deposit second and third run with a 3.15 mm electrode. (Refer to Skill Information.)
- Remove the hot job by using a pair of tongs.
- Clean the weldments and inspect the surface defects.
- Repeat the exercise until you are able to weld the joint without defect.

## Skill Sequence

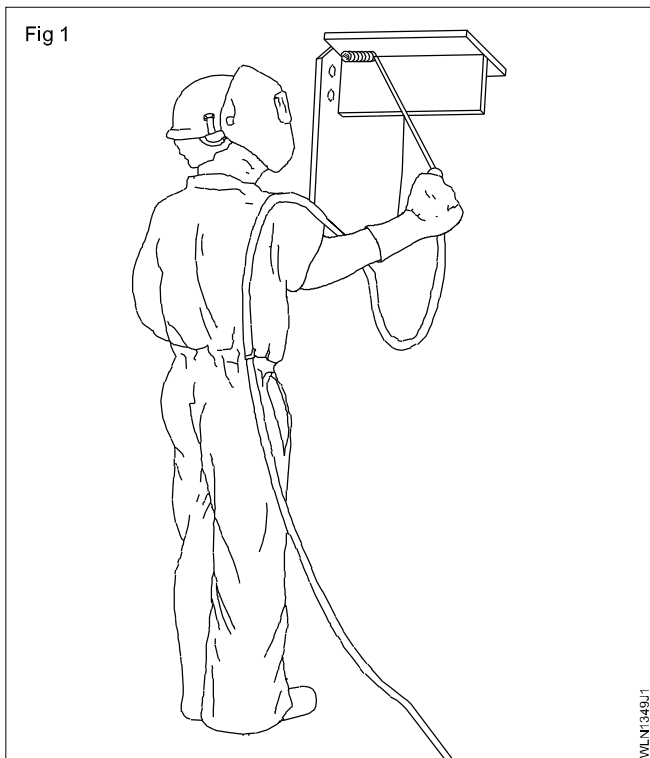
### Fillet 'T' joint on MS plate 10mm thick in over head position

**Objective:** This shall help you to

- **prepare and weld fillet 'T' joint on MS plate 10mm thick in over head position.**

#### Job setting

Set the job in overhead position on the positioner. (Fig 1)

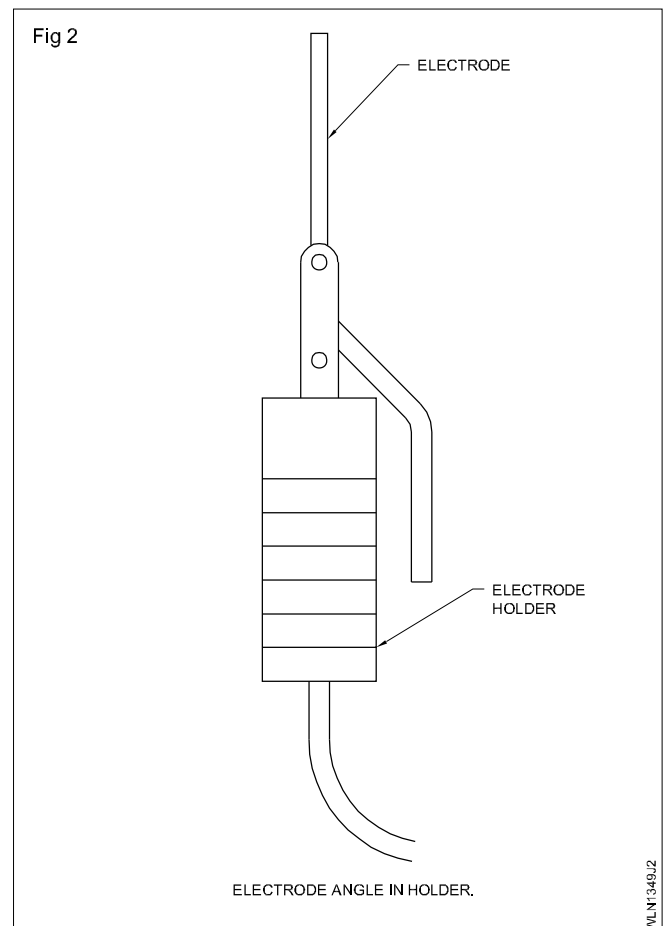


Fix the electrode as shown in Fig 2.

Start the bead at the left side. (Fig 1)

Use a 30° work angle off the vertical plate as shown in Fig3.

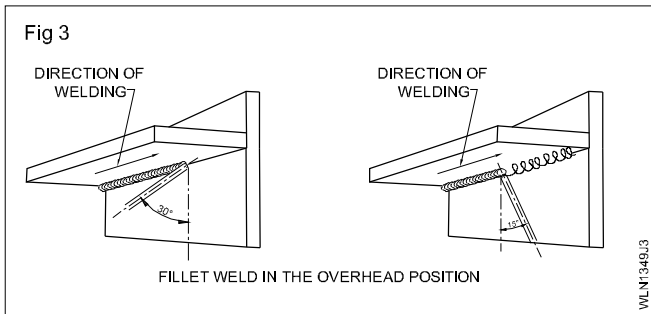
Work angle is the angle between the electrode and the job surface.



Use a drag angle of approximately 10-15° to the direction of the weld.

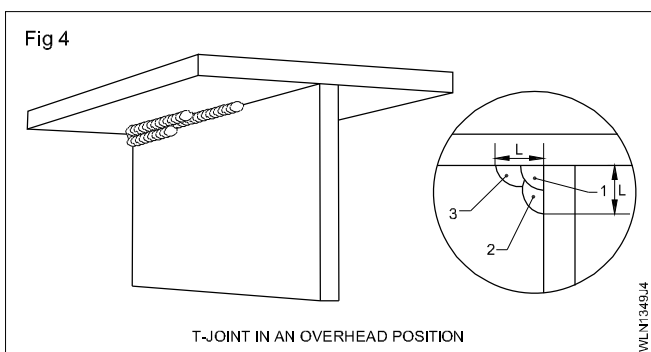
Drag angle is the angle between the electrode and the line of weld.

Maintain a short arc all the time.



When multi-passes are used the second pass should be placed between the first pass and the vertical plate so that the second bead overlaps the first pass, (Fig 4) by about 2/3rd of its width.

The third bead should cover the top horizontal plate and about two-third of bead two. The leg lengths "L" of the weld should be equal. (Fig 4)



Welding in the overhead position is not difficult if you remember to keep the puddle flat and small.

If the molten metal becomes too fluid and tends to sag, whip your electrode away quickly from the crater and allow the metal to solidify.

**Do not attempt to deposit too much weld metal at one time.**

All the slag must be removed before you deposit the next run.

The process is quite hazardous because of flying spatters and the possibility of molten metal from the puddle dropping on to the operator. By maintaining a short arc length and rapid electrode manipulation this difficulty may be overcome to a great extent.

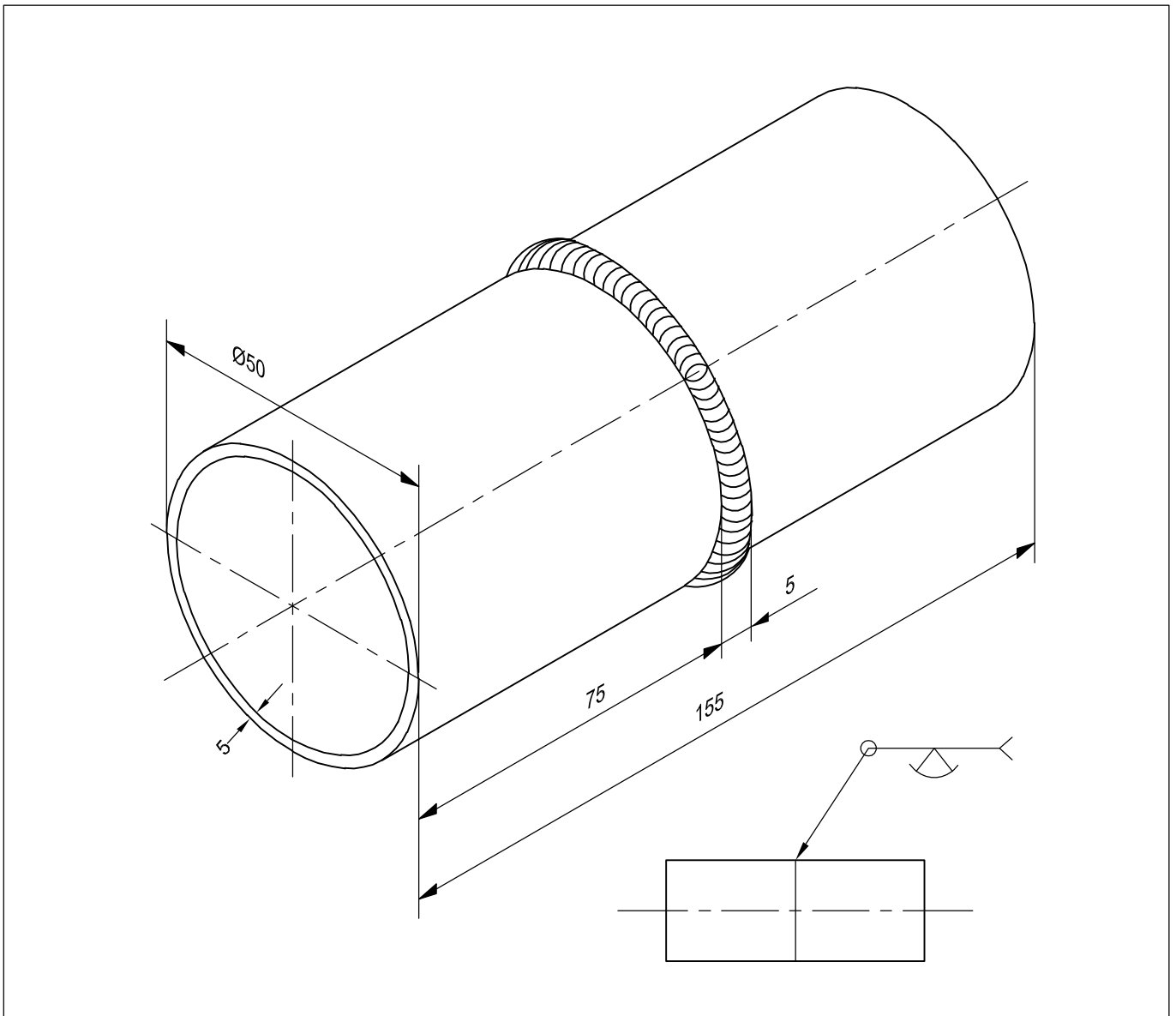
The discomfort of the cable can be minimized by dropping it over the shoulder if you are welding in a standing position as shown in Fig 1 or over the knees if in a sitting position.

**Inspection:** Remove the slag from the weld and inspect the joint for surface and external defects.

**Pipe welding butt joint on MS pipe  $\varnothing 50\text{mm}$  and 5mm wall thickness in 1G position (SMAW-20)**

**Objectives:** At the end of this exercise you shall be able to

- cut and bevel the pipe for welding
- tack pipes for butt welding
- make root run by rotation method
- make filling run by rotation
- clean the job and inspect for defects.



2	$\varnothing 50 \times 5 - 75$	-	Fe 310 - W	-	-	1.3.50
NO.OFF	STOCK SIZE	SEMI-PRODUCT	MATERIAL	PROJECT NO.	PART NO.	EX. NO.
SCALE NTS		<b>PIPE WELDING BUTT JOINT ON MS PIPE  <math>\varnothing 50\text{mm}</math> AND 5mm WALL THICKNESS IN 1G  POSITION (SMAW-20)</b>			TOLERANCE $\pm 1$	TIME 15 Hrs
					CODE NO. WLN1350E1	

## Job Sequence

- Cut the pipes to the given size.
- File pipe ends to be at right angle to the pipe axis.
- Grind the edges to 30 to 35° bevel maintaining 1.5 to 1.75 mm root face.
- Remove the burrs and rust from the pipe ends.
- Arrange the 2 pipes to form as a butt joint.
- Use a fixture or V profile of an angle iron to align pipes.

### Wear protective clothing.

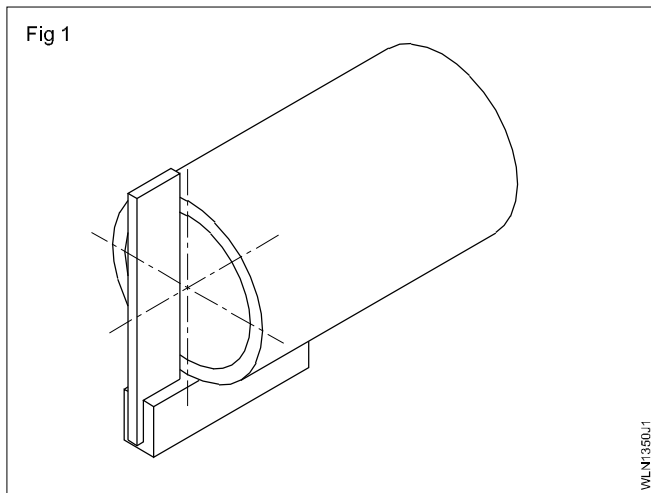
- Switch 'on' the machine and select a 3.15 mm  $\varnothing$  electrode for tacking and the root run and set an 100 amps current.
- Put 4 tacks at regular intervals adjusting 2 mm root gap between the pipes using spacers.

- Ensure that each tack ends with a key hole.
- Check and ensure that the pipes are in line after tacking.
- Set 110 amp for a 3.15mm $\varnothing$  electrode for root run.
- Deposit the root run in flat position by without rotating the pipe.
- Welding using the keyhole technique ensures root penetration.
- Remove slag from the root thoroughly.
- Deposit the second and third run using a 3.15 mm  $\varnothing$  electrodes i.e. the same as for the root run.
- Clean and inspect the joint.

## Skill Sequence

Cut the pipes to the given size by a hacksaw.

Check the squares of the pipe end by using a try square. (Fig 1) and file the pipe end so that it is square with the pipe axis.

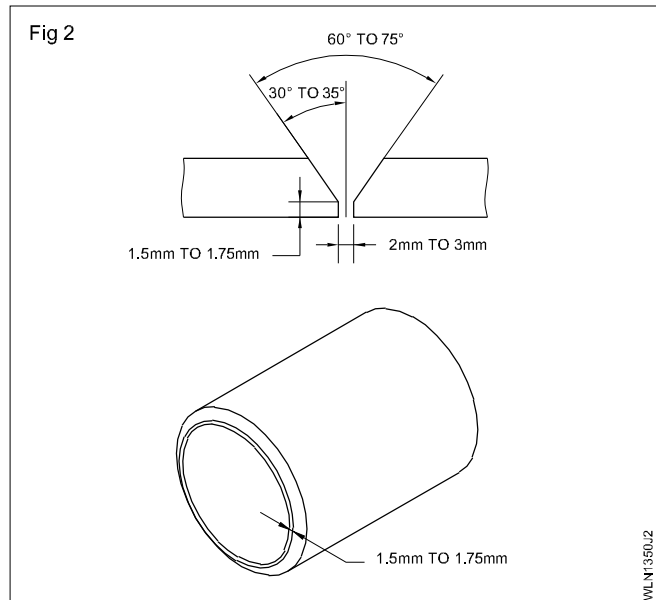


Prepare 30 to 35° bevel on one end of each pipe, leaving 1.5 to 1.75 mm root face by grinding or by filing. (Fig 2)

Switch 'on' the machine and adjust 110 amp current for 3.15 mm  $\varnothing$  medium coated M.S. electrode (B.I.S code ER4211). Use DCEN polarity.

Before tacking, align the pipes on V profile of an angle iron with 2 mm root gap (Fig 3) and tack them as shown in Fig 4. Check the gap using a 2 mm rod.

Place the electrode in the holder, as in Fig 6. Use a 90 degree angle or a 45 degree angle away from the end of the holder.

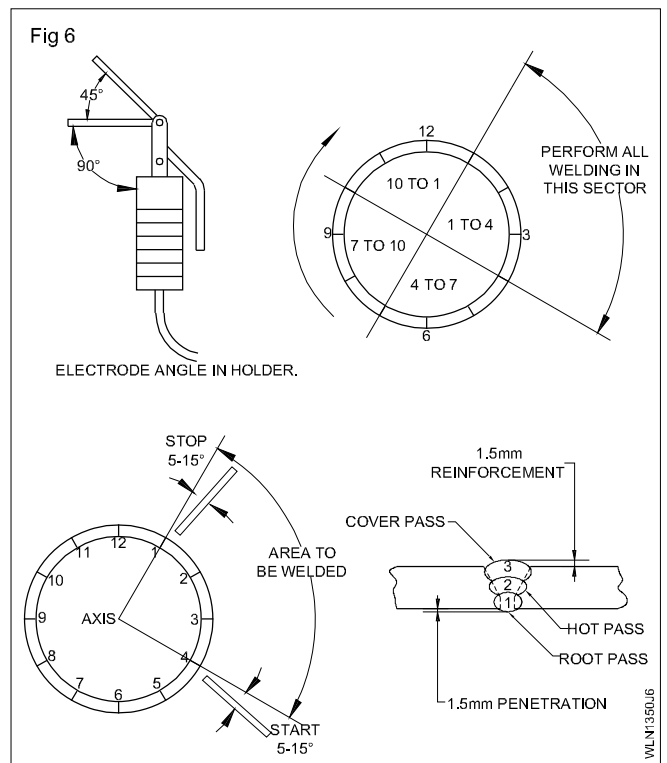
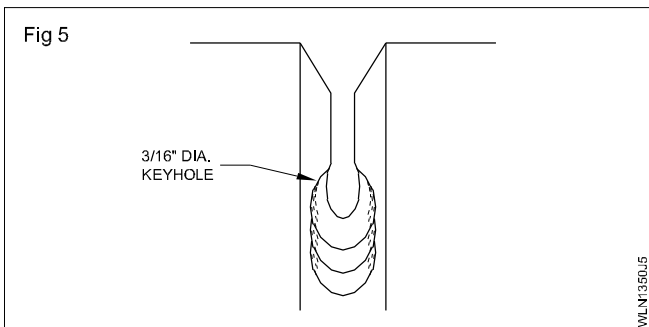
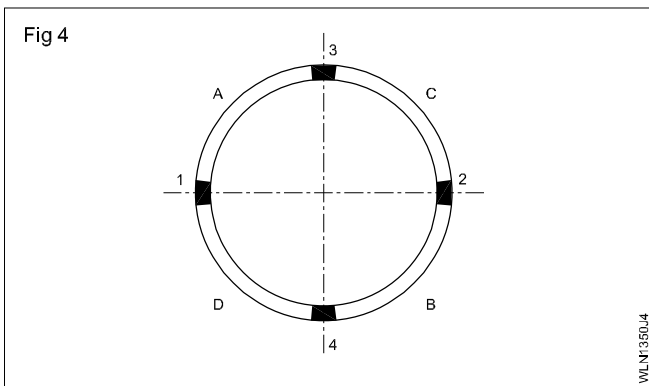
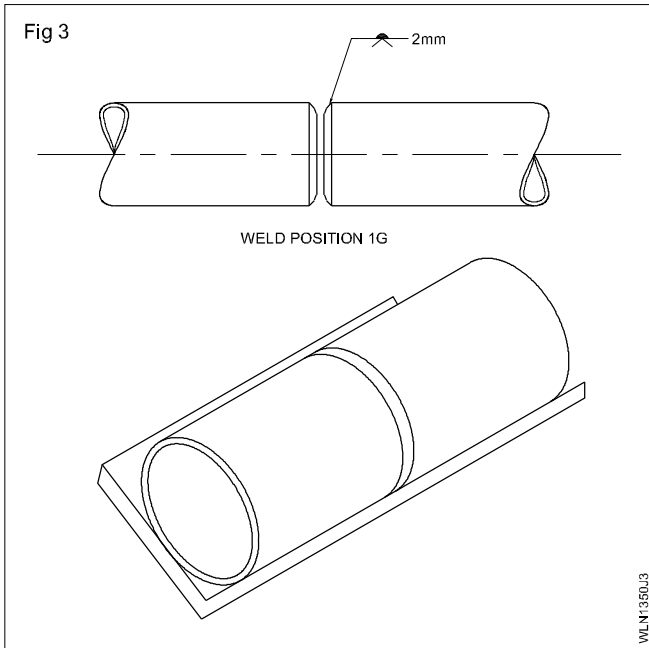


Position yourself so that you are at a 90 degree angle to the pipe. Be sure you are comfortable.

Strike the arc, on the bevel, at approximately 3 o'clock. Carry it down to 4 o'clock. Pause long enough for the root faces to melt away and for a keyhole to form Fig 5. Then reverse your electrode direction.

To run the first pass uphill, utilize the whipping method, as in welding plate in the vertical position. Use an electrode at a push angle of 5 to 15 degrees upward, as in Fig 6. Whip upward, taking care not to damage the surface of the pipe on either side of the V groove. Stop when you reach 1 o'clock, as shown in Fig 6. Clean thoroughly.

Turn the pipe toward you one quarter of a turn. Then proceed in the same manner until the first pass is completed. Be sure to start the next electrode slightly below the crater.



The second pass (hot pass) and third pass (cover pass) can be welded using 3.15mm electrode with either the triangle motion or the alternate weave, as in vertical plate welding. Take care to pause at the sides of the joint. Burn out any entrapped slag and fill in any undesirable undercut.

The sequence of beads is shown in Fig 6. Adhere to the maximum root and face reinforcement shown.

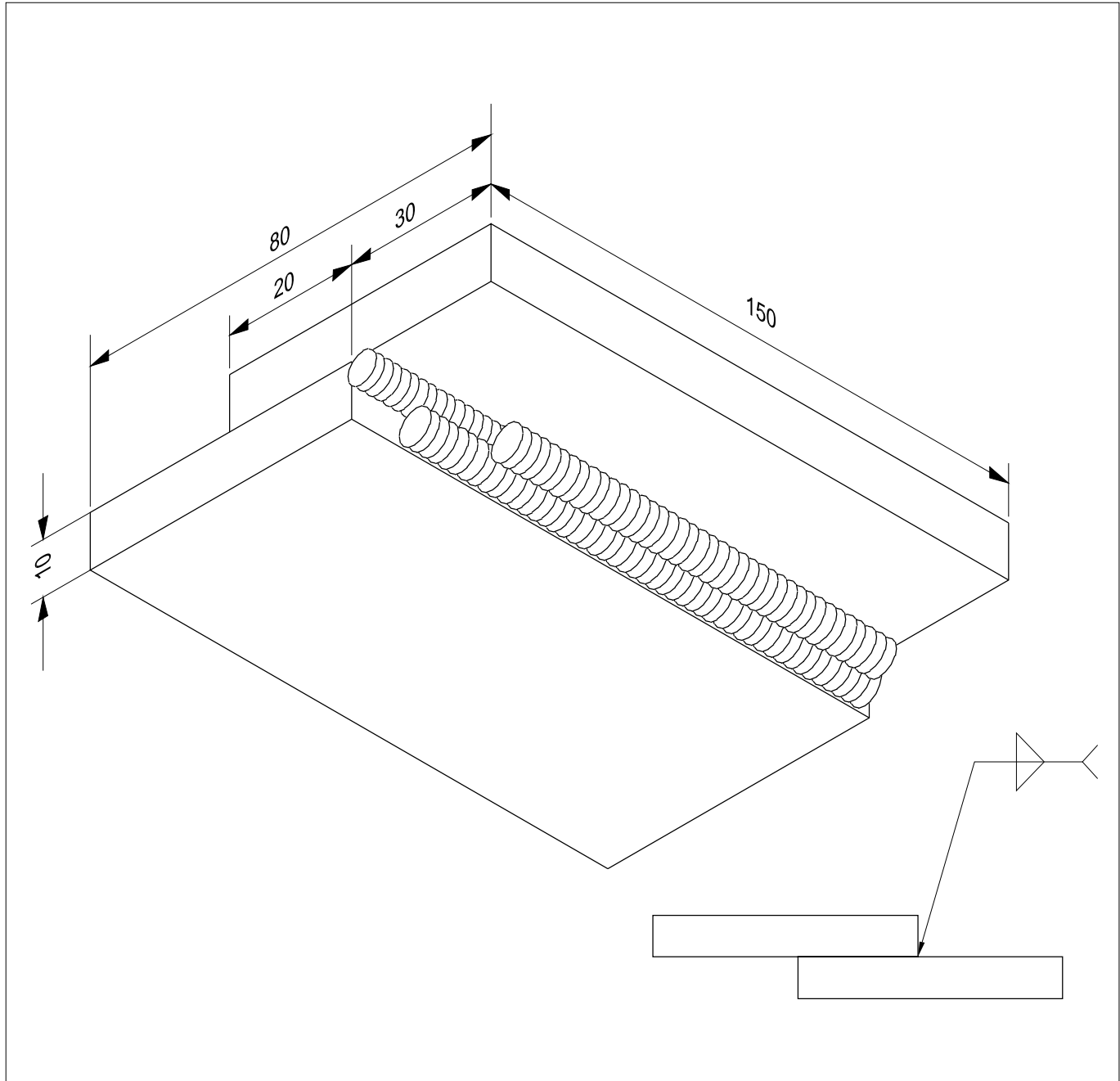
When you make the connection on completing the pass, be sure to overlap slightly. Break the arc by slowly drawing it away from the puddle.

Clean and inspect the joint for surface defects.

**Fillet - lap joint on MS plate 10mm thick in over head position (4G)-(SMAW-21)**

**Objectives:** At the end of this exercise you shall be able to

- weld fillet lap joint in overhead position
- clean and inspect the job for surface defects.



2	50 ISF 10 - 150	-	Fe 310 - W	-	-	1.3.51
NO.OFF	STOCK SIZE	SEMI-PRODUCT	MATERIAL	PROJECT NO.	PART NO.	EX. NO.
SCALE NTS	<b>FILLET LAP JOINT ON M.S. PLATE                  10mm THICK IN OVERHEAD POSITION                  (4G)-(SMAW-21)</b>				TOLERANCE ±1	TIME 10 Hrs
					CODE NO. WLN1351E1	

## Job Sequence

- Mark the plate and cut to given size.
- Prepare the square edges.
- Set the lap joint without gap and tack the plate on both ends.
- Clamp the job for overhead lap welding.
- Select 3.15 $\phi$  electrode and set the current.
- Hold the electrode at an angle of 45° to the plate surface and an angle of 15° to the perpendicular to the line of weld.
- Lay the first bead at the root without weaving the electrode.
- Clean the slag using a chipping hammer.
- Deposit 2<sup>nd</sup> and 3<sup>rd</sup> run using stringer beads.
- Deslag, clean and inspect the joint.

## Skill Sequence

### Fillet lap joint on MS plate 10mm thickness in over head position

**Objective:** This shall help you to

- prepare and weld fillet lap joint on MS plate 10mm thickness in over head position.

#### Preparation and job setting

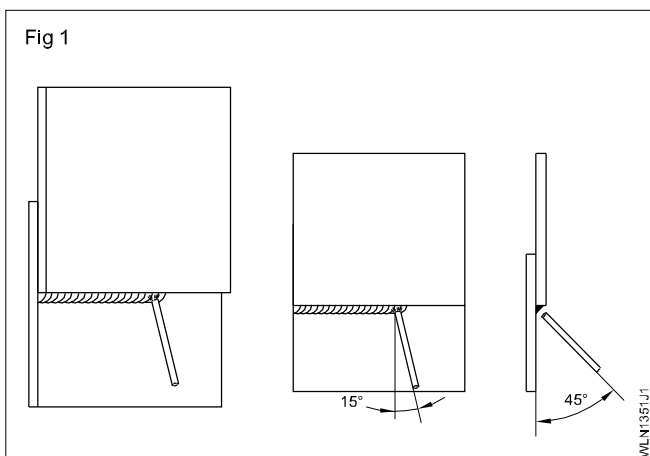
Mark and cut the plate to the given size by gas cutting.  
Clean the surfaces of the plates and file to square edge.  
Set lap fillet without gap and tack the plates at both ends.  
Keep the lapping distance as 20mm.

**Wear leather gloves, hand sleeves, apron, leg guard, helmet etc.**

Clamp the job for overhead welding.

Select a M.S. electrode 3.15 mm  $\phi$  and set 110 amps current.

Hold the electrode so that it bisects the angle between the edge of the top plate and the surface of the bottom plate, and is inclined slightly away from the crater, say 15°. (Fig 1)



Lay the first bead at the root of the joint with a short arc without electrode weaving.

Remove the slag from the bead using a chipping hammer and clean with a wire brush.

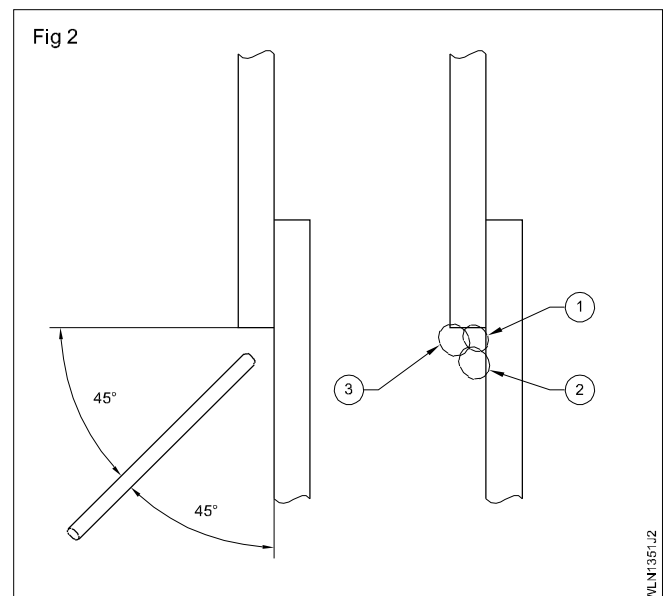
Use a M.S. electrode 3.15 mm  $\phi$  and deposit the 2<sup>nd</sup> run with 110 amps. current, between the 1<sup>st</sup> bead and the surface of the plate, maintaining a short arc. The electrode angle is the same as the one mentioned for root run.

Deslag the second bead thoroughly.

Use a 3.15 mm electrode and set 110 amps current.

Deposit the 3<sup>rd</sup> bead in between the first bead and the bottom edge of the top plate (Fig 2) with a short arc and with an electrode angle of 45° to the surface of the plate to avoid the edge melting off the top plate.

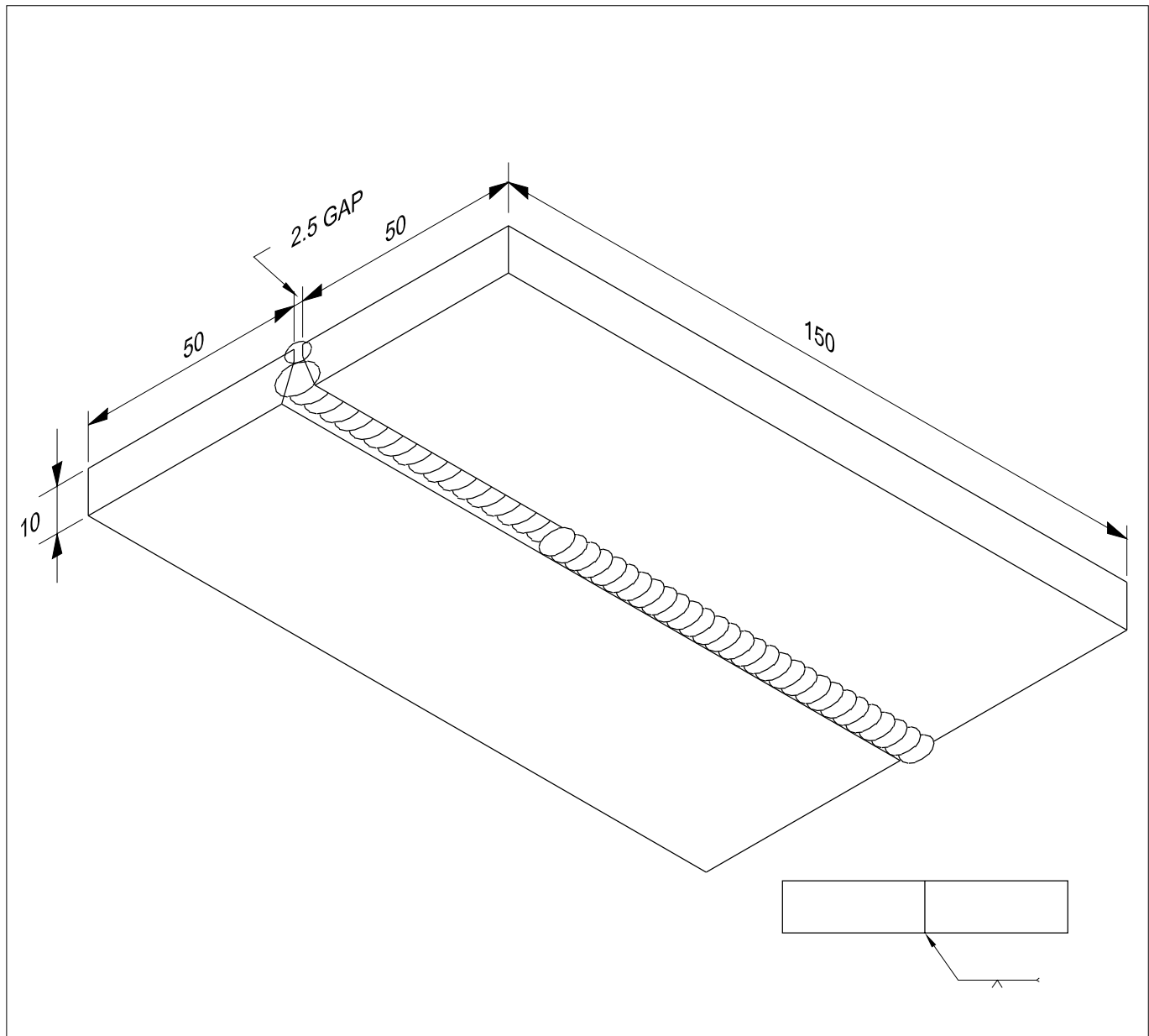
Clean the weld thoroughly and inspect for defects, like undercut, porosity, uneven ripples and the melting off of the edge plate.



**Single "V" butt joint on MS plate 10mm thick in over head position (4G)-(SMAW-22)**

**Objectives:** At the end of this exercise you shall be able to

- select electrode, current, polarity and arc length
- preset and tack the beveled plate with root gap
- place the joint in overhead position
- deposit root run, 2<sup>nd</sup> run, 3<sup>rd</sup> run
- Clean the weldment and inspect for surface defects.



2	50 ISF x 10 - 150	-	Fe 310 - W	-	-	1.3.52
NO.OFF	STOCK SIZE	SEMI-PRODUCT	MATERIAL	PROJECT NO.	PART NO.	EX. NO.
SCALE NTS	SINGLE 'V' BUTT JOINT ON M.S. PLATE 10mm THICK IN OVERHEAD POSITION. (4G)-(SMAW-22)				TOLERANCE ±1	TIME 15 Hrs
					WLN1352E1	



## Job Sequence

- Prepare the plates to size as per drawing.
- Clean the beveled plate.
- Use spacers, maintain 2.5 mm root gap, tack one end and adjust the gap and tack the other end.
- Preset the plates 3° to take care of distortion as done in Ex.No.E32/3. 16.

### Ensure safety apparels are worn.

- Arrange the work piece in overhead position.
- Select a 3.15 mm M.S. electrode and set 110 amps current.
- Weld the root run with short arc with uniform welding speed, so that a uniform root penetration can be obtained.

- Chip the slag and inspect the weld.

**Use a pair of tongs to hold hot jobs.**

**Use a chipping hammer and wire brush for cleaning.**

**Use chipping goggles for protection of eyes.**

- Deposit second covering run with a weaving motion.
- Use a 3.15 mm electrode with 110 amps current.
- Deposit the third covering run similar to the second run.

Repeat this exercise until you can produce good welds. (Refer to Skill Sequence.)

## Skill Sequence

### Single 'V' butt joint on MS plate 10mm thick in over head position

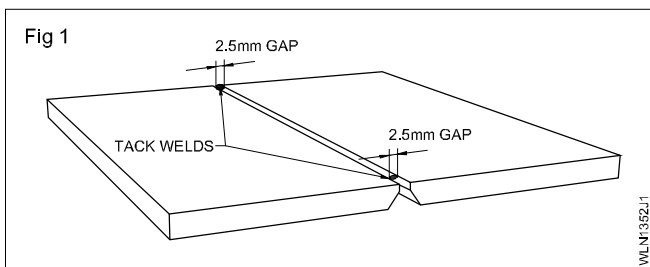
**Objective:** This shall help you to

- **prepare and weld single 'V' butt joint on MS plate 10mm thick in over head position.**

This type of joint is used very extensively for welding huge structures as in rail coach, ship building industries and earth moving equipment manufacture and for welding big structures and huge pipes at side.

#### Setting and tacking

Set the pieces as single V butt joint with 2.5 mm root gap. (Fig 1) Tack at both ends.



Use a 3.15 mm  $\varnothing$  M.S. electrode and set a current of 100<sup>o</sup> amps.

Preset the plates

Fix the work piece in the overhead position. (Fig 2)

Adjust it to a suitable height.

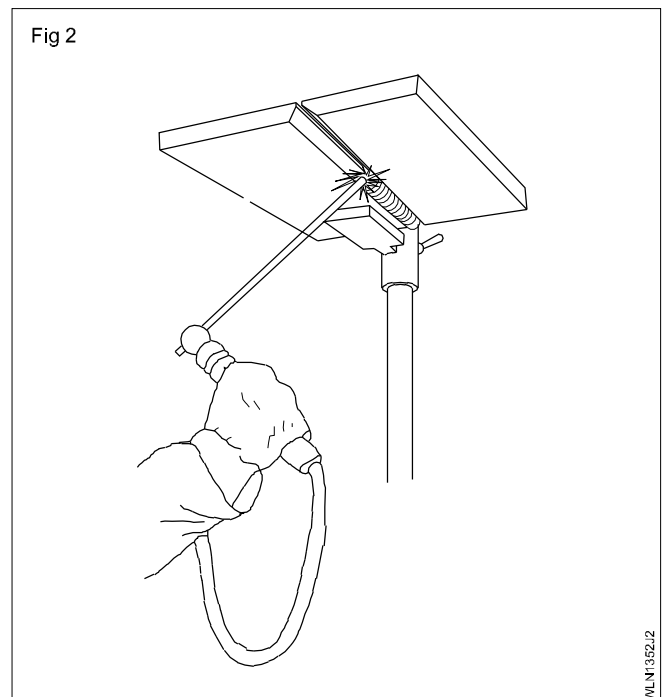
**Use a light welding cable to reduce the load on your arms.**

#### Weld root run

The electrode should be kept as near as possible and square to the surface of the plate and at a small angle to the direction

of the weld. (Fig 3) Keep the electrode well up in the gap and control the 'keyhole' to get a small reinforcement on the weld on the root side. (Figs 3 and 4)

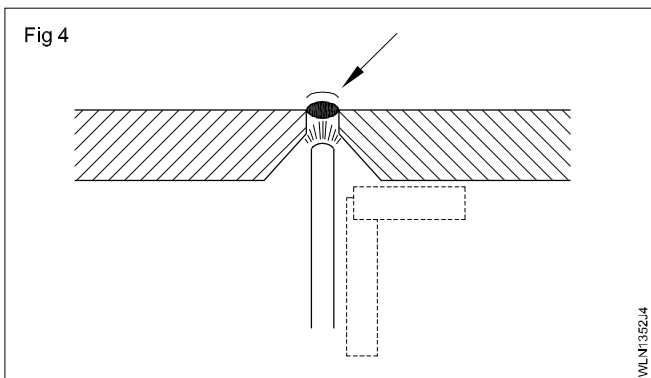
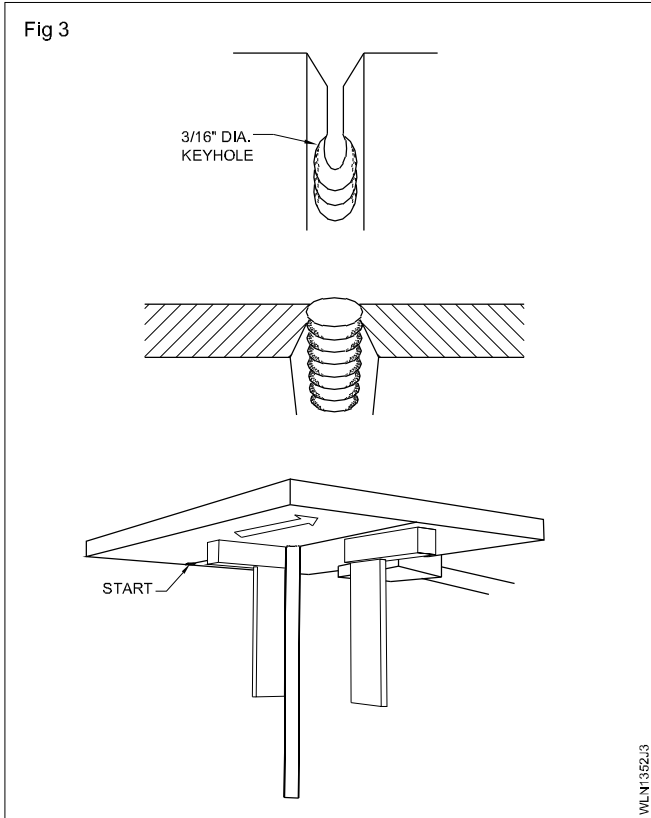
Fig 2



Keep a short arc length. (Fig 4)

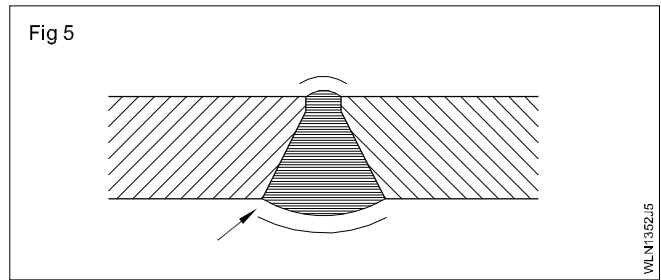
**Control the slag. The slag must not drop into or flood the weld pool.**

Weld up to the end of the work piece, chip off the slag after cooling and inspect the weld.



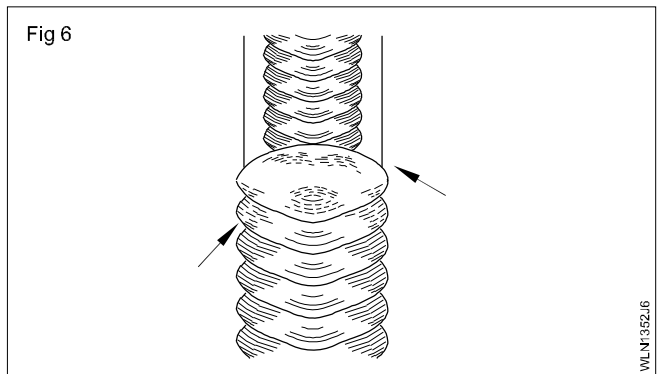
### Weld second and third passes

Select a 3.15 electrode and set 100 amps current. Use weaved beading technique. The electrode should be moved across the face of the weld. (Fig 5)



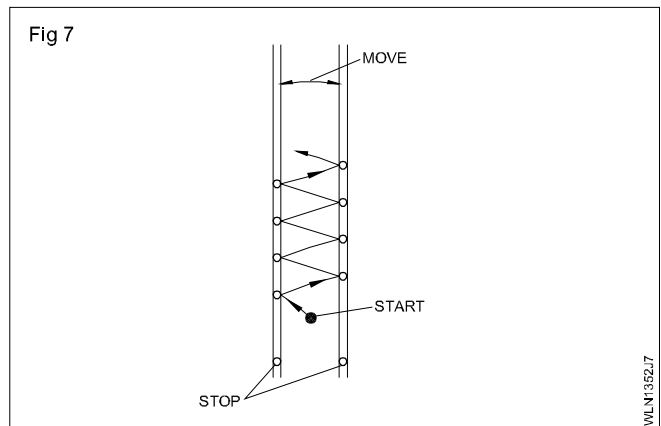
**Do not deposit too much metal in the center of the bead causing it to sag in the center.**

The side-to-side movement should be kept within the required weld size. (Fig 6)



Stop a while at the sides of the weld to prevent undercut. (Fig 7)

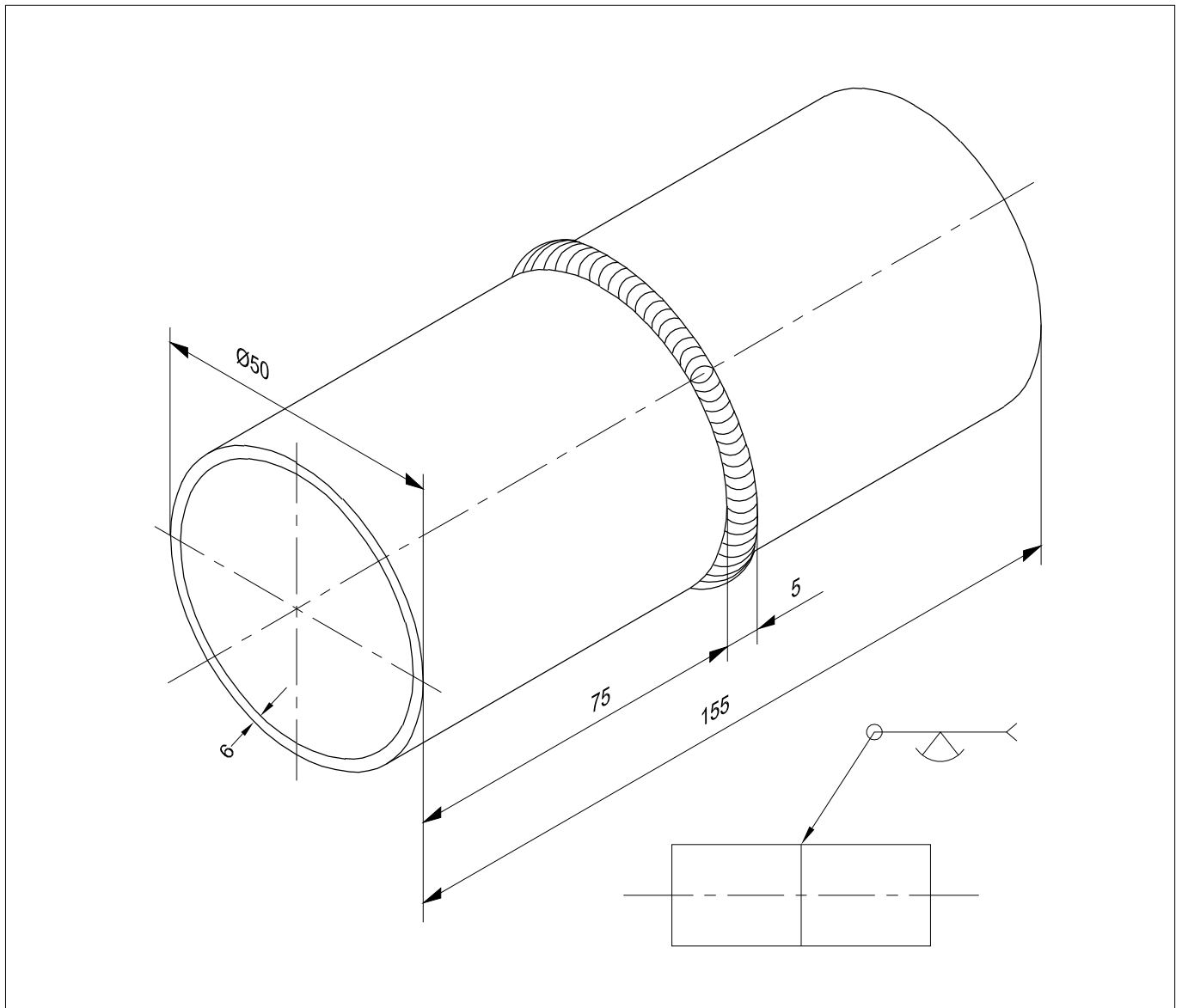
Chip off the slag and inspect the weld.



**Pipe butt joint on MS pipe  $\varnothing 50\text{mm}$  wall thickness 6mm (1G Rolled) position (SMAW-23)**

**Objectives:** At the end of this exercise you shall be able to

- cut and bevel the pipe for welding
- tack pipes for butt welding
- make root run by rotation method
- make filling run by rotation
- clean the job and inspect for defects.



2	$\varnothing 50 \times 6 - 75$	-	Fe 310 - W	-	-	1.3.53
NO.OFF	STOCK SIZE	SEMI-PRODUCT	MATERIAL	PROJECT NO.	PART NO.	EX. NO.
SCALE NTS	<b>PIPE BUTT JOINT ON                  M.S. PIPE <math>\varnothing 50\text{mm}</math> x 6mm WALL THICKNESS IN                  1G (ROLLED) POSITION (SMAW-23)</b>				TOLERANCE $\pm 1$	TIME 10 Hrs
					CODE NO. WLN1353E1	

## Job Sequence

- Cut the pipes to the given size.
- File pipe ends to be at right angle to the pipe axis.
- Grind the edges to 30 to 35° bevel maintaining 1.5 to 1.75 mm root face.
- Remove the burrs and rust from the pipe ends.
- Arrange the 2 pipes to form as a butt joint.
- Use a fixture or V profile of an angle iron to align pipes.

### Wear protective clothing.

- Switch 'on' the machine and select a 3.15 mm  $\varnothing$  electrode for tacking and the root run and set an 100 amps current.

- Put 4 tacks at regular interval adjusting 2 mm root gap between the pipes using spacers.
- Ensure that each tack ends with a key hole.
- Check and ensure that the pipes are in line after tacking.
- Set 110 amp for a 3.15mm $\varnothing$  electrode for root run.
- Deposit the root run in flat position by rotating the pipe.
- Welding using the keyhole technique ensures root penetration.
- Remove slag from the root thoroughly.
- Deposit the second and third run using a 3.15 mm  $\varnothing$  electrodes i.e. the same as for the root run.
- Clean and inspect the joint.

## Skill Sequence

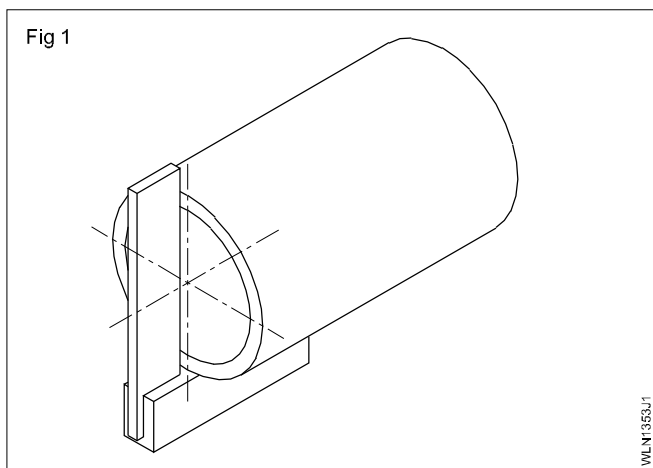
### Pipe joint on MS pipe $\varnothing 50\text{mm} \times 6\text{mm}$ wall thick in over head rolled position

**Objective:** This shall help you to

- prepare and weld pipe joint on MS pipe  $\varnothing 50\text{mm} \times 6\text{mm}$  wall thick in over head rolled position.

Cut the pipes to the given size by a hacksaw.

Check the squares of the pipe end by using a try square. (Fig 1) and file the pipe end so that it is square with the pipe axis.

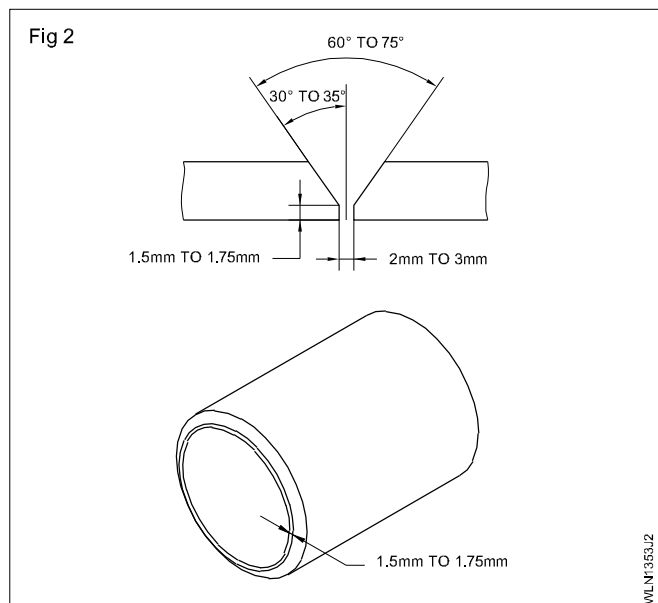


Prepare 30 to 35° bevel on one end of each pipe, leaving 1.5 to 1.75 mm root face by grinding or by filing. (Fig 2)

Switch 'on' the machine and adjust 110 amp current for 3.15 mm  $\varnothing$  medium coated M.S. electrode (B.I.S code ER4211). Use DCEN polarity.

Before tacking, align the pipes on V profile of an angle iron with 2 mm root gap (Fig 3) and tack them as shown in Fig 4. Check the gap using a 2 mm rod.

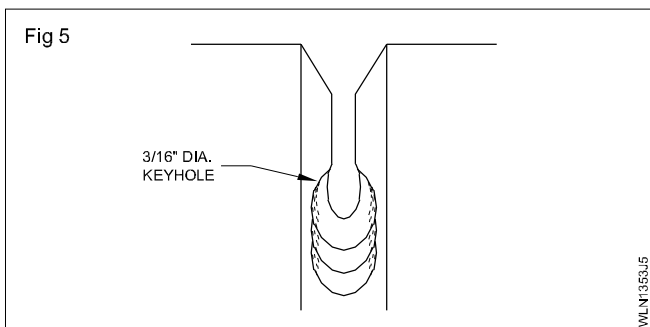
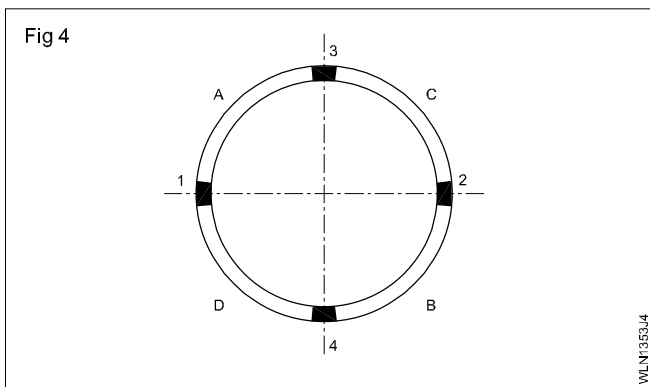
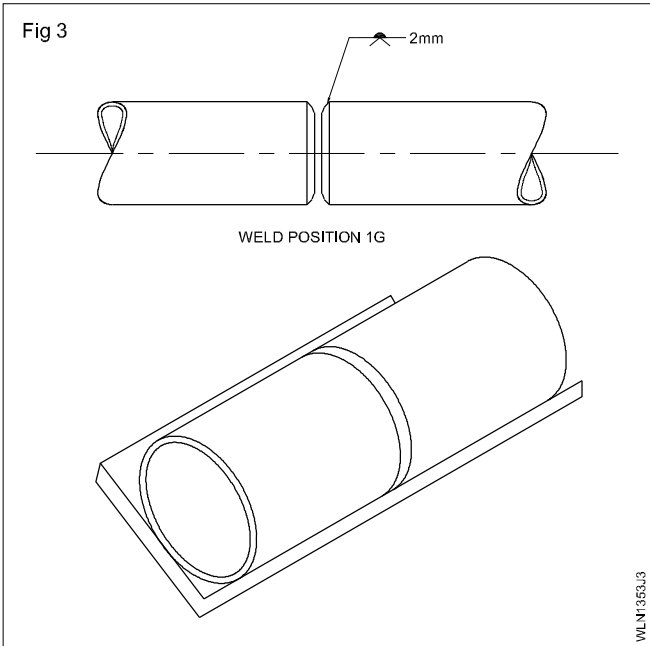
Place the electrode in the holder, as in Fig 6. Use a 90 degree angle or a 45 degree angle away from the end of the holder.



Position yourself so that you are at a 90 degree angle to the pipe. Be sure you are comfortable.

Strike the arc, on the bevel, at approximately 3 o'clock. Carry it down to 4 o'clock. Pause long enough for the root faces to melt away and for a keyhole to form Fig 5. Then reverse your electrode direction.

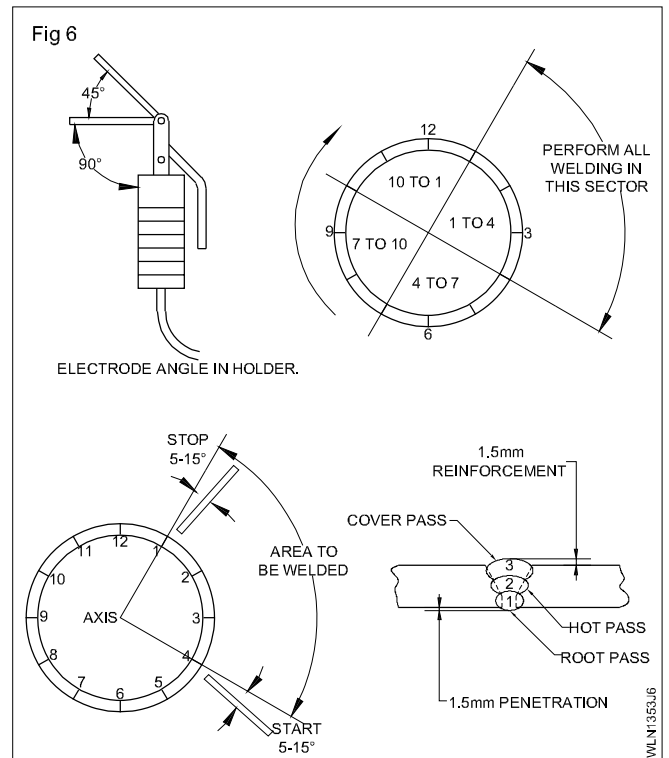
To run the first pass uphill, utilize the whipping method, as in welding plate in the vertical position. Use an electrode at a push angle of 5 to 15 degrees upward, as in Fig 6. Whip upward, taking care not to damage the surface of the pipe on either side of the V groove. Stop when you reach 1 o'clock, as shown in Fig 6. Clean thoroughly.



Turn the pipe toward you one quarter of a turn. Then proceed in the same manner until the first pass is completed. Be sure to start the next electrode slightly below the crater.

The second pass (hot pass) and third pass (cover pass) can be welded using 3.15mm electrode with either the triangle motion or the alternate weave, as in vertical plate welding. Take care to pause at the sides of the joint. Burn out any entrapped slag and fill in any undesirable undercut.

The sequence of beads is shown in Fig 6. Adhere to the maximum root and face reinforcement shown.



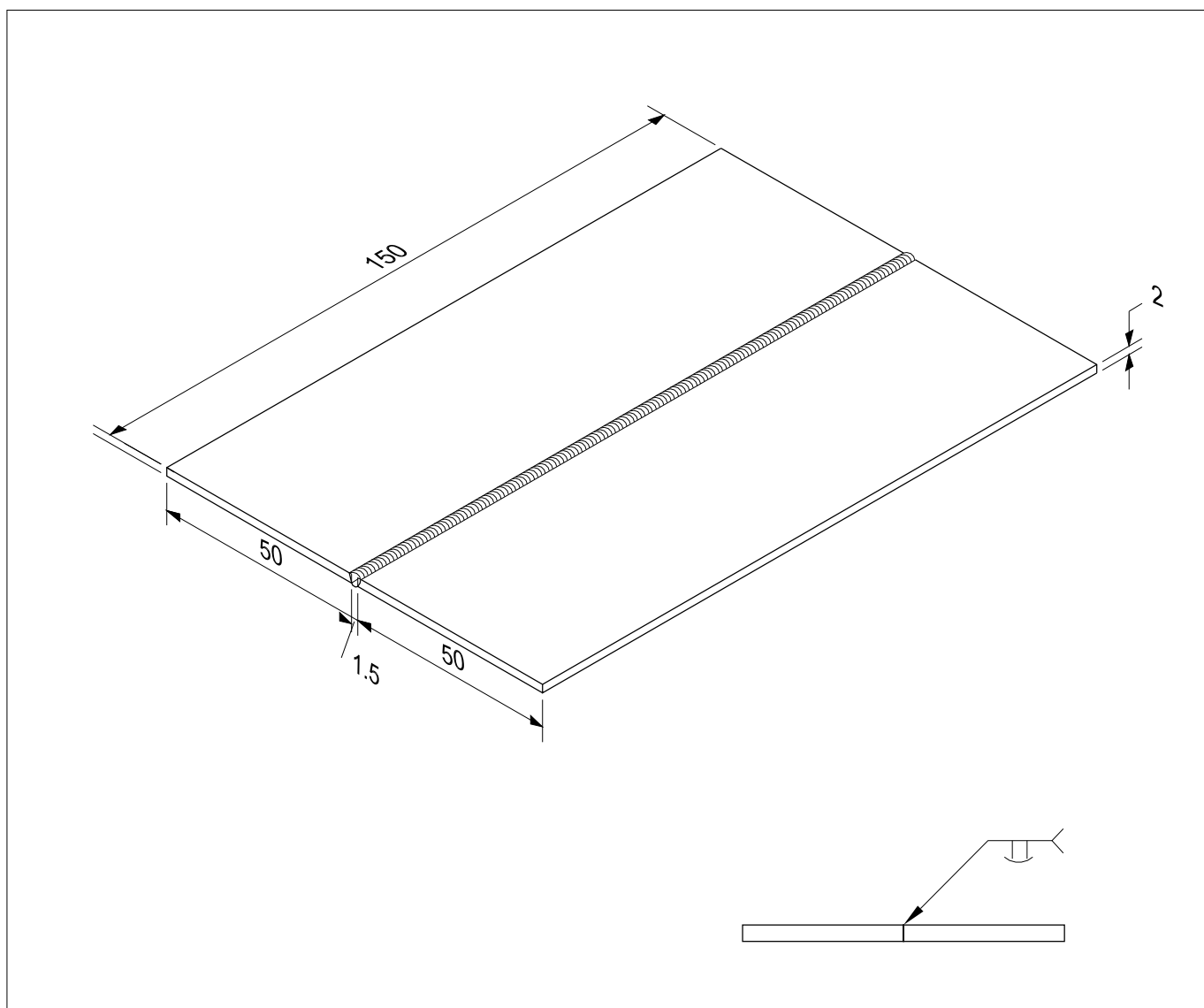
When you make the connection on completing the pass, be sure to overlap slightly. Break the arc by slowly drawing it away from the puddle.

Clean and inspect the joint for surface defects.

Square butt joint on stainless steel sheet 2mm thick in flat position (1G)  
 (OAW-17)

**Objectives:** At the end of this exercise you shall be able to

- clean the chromium oxides and other impurities that exist on the surface of the stainless steel sheet
- prepare square edges on stainless steel sheets
- apply stainless steel flux on the edges of the sheet to be welded
- select suitable stainless steel filler rod, nozzle, gas pressure
- set a perfect neutral flame
- weld the square butt joint with uniform root penetration using leftward technique
- clean the joint and inspect for weld defects.



2	150 x 50 x 2	-	X 04 Cr19 Ni9	-	-	1.3.54
NO.OFF	STOCK SIZE	SEMI-PRODUCT	MATERIAL	PROJECT NO.	PART NO.	EX. NO.
SCALE NTS	SQUARE BUTTJOINT ON STAINLESS STEEL SHEET 2mm THICK IN FLAT POSITION.(1G)-(OAW-17)				TOLERANCE ±1	TIME 8 Hrs
					CODE NO. WLN1354E1	

## Job Sequence

- Prepare the stainless steel sheet as per dimensions.
- Clean the edges of the sheets.
- Select the nozzle No. 5 for 3.15 mm thickness.
- Select the stainless steel flux and apply on both sides of the edges of the joint by using a 12mm paint brush and apply on filler rod.
- Set and align the stainless steel sheet as square butt joint.
- Set perfect neutral flame.
- Tack-weld at every 50mm length of the butt joint.
- Weld the joint using leftward technique.
- Clean the joint and inspect the weld for defects.

## Skill Sequence

### Square butt joint on stainless steel sheet 2mm thick in flat position

**Objective:** This shall help you to

- **prepare and weld square butt joint on stainless steel sheet 2mm thick in flat position.**

Prepare the stainless steel sheet as per dimensions given in the sketch.

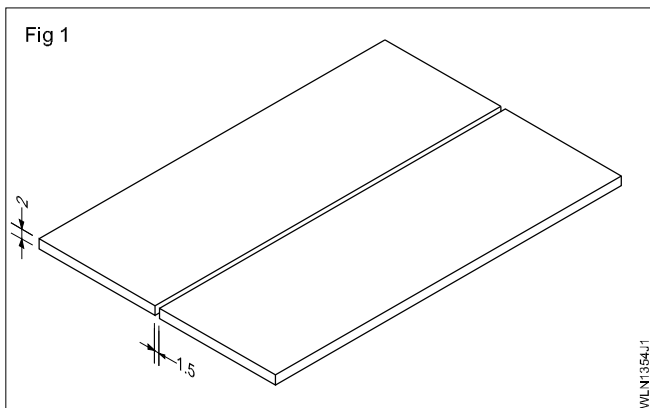
Use a stainless steel wire brush to clean the edges of the sheets and remove any chromium oxide and other impurities from the edges.

Select nozzle No. 5 and fix on the blowpipe.

Select a 1.6 mm  $\varnothing$  specially treated columbium bearing 18/8 type stainless steel filler rod, or cut strips from the base metal to use as filler rod. 18/8 stainless steel means the alloy steel contains 18% chromium, 8% nickel and the balance % is iron, carbon % etc.

Select good quality flux which contains zinc chloride and potassium dichromate; make powdered flux in a pasty form by adding water. Apply the flux on both sides of the plate and filler rod.

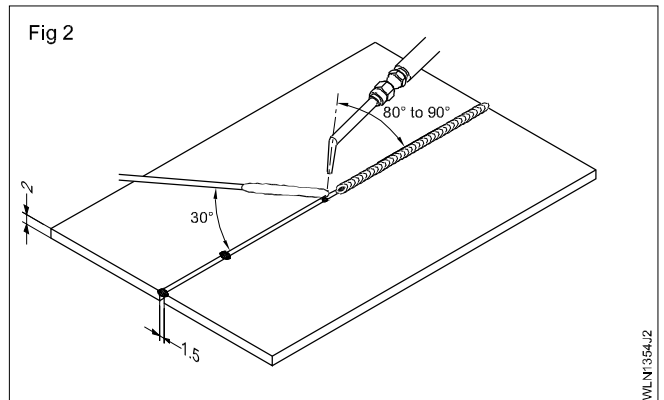
Set the sheets as butt joint on a thick metal plate with 1.5 mm gap as shown in Fig 1.



Set a strict neutral flame or slightly carburizing flame so as to prevent the formation of oxidizing flame which is harmful.

Tack-weld on both ends of the joints and for every 50 mm in between them.

Start welding from the right hand side by holding the blow-pipe at an angle of  $80^\circ$  to  $90^\circ$  and the filler rod at  $20^\circ$  to  $30^\circ$ . (Fig 2)



**Ensure uniform penetration at the root of the joint.**

Finish the weld by filling up the crater at the end of the bead.

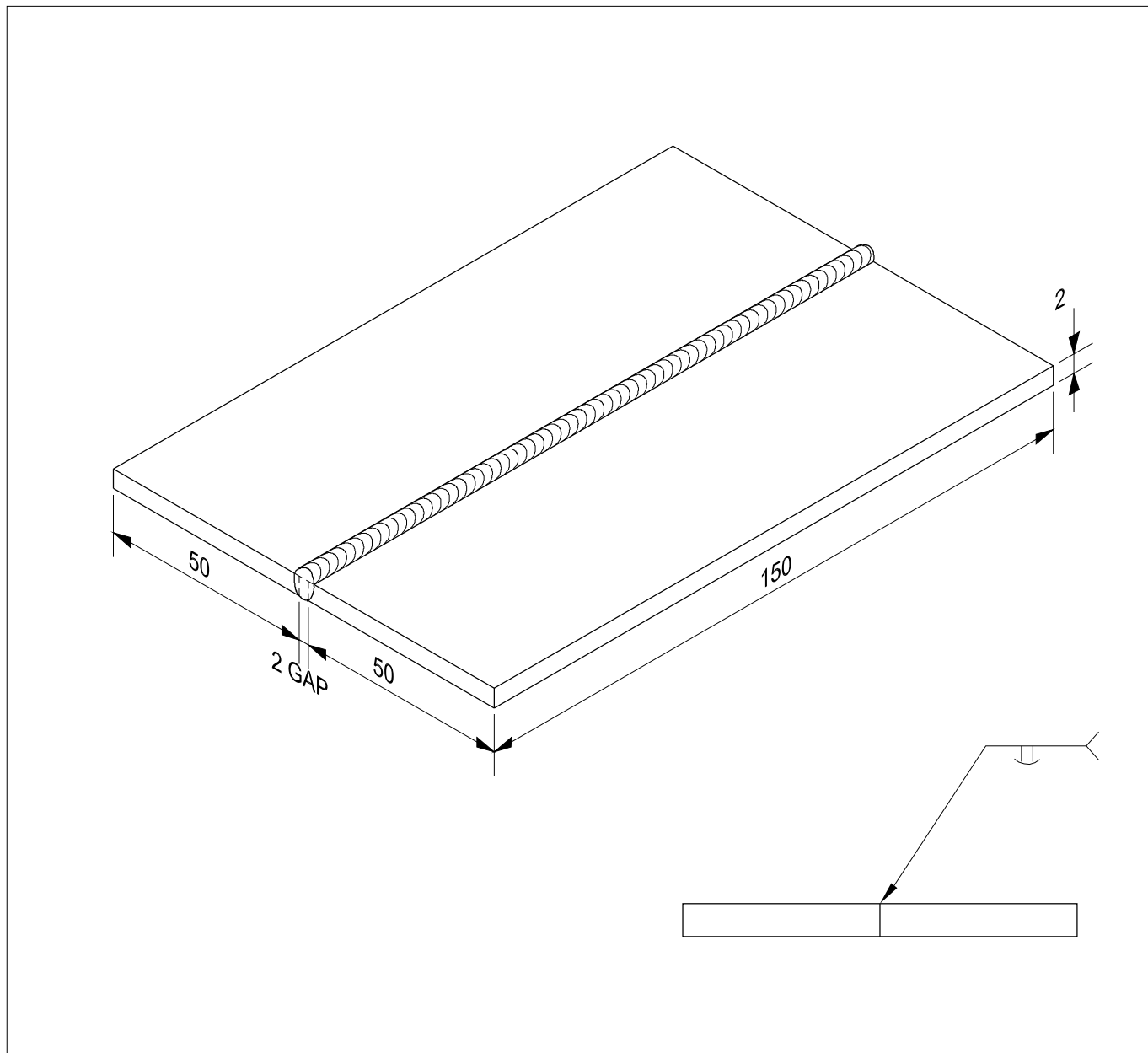
Clean the weld bead and inspect.

**Ensure the complete removal of the flux residues.**

**Square butt joint on stainless steel sheet 2mm thick in flat position (SMAW-24)**

**Objectives:** At the end of this exercise you shall be able to

- set and tack the stainless steel sheets
- select the electrode, polarity and set the current
- finish the weld in a single pass
- clean and inspect the weld.



2	ISST 50 x 2 - 150	-	X 04 Cr 19 Ni 9	-	-	1.3.55
NO.OFF	STOCK SIZE	SEMI-PRODUCT	MATERIAL	PROJECT NO.	PART NO.	EX. NO.
SCALE NTS	<b>SQUARE BUTT JOINT ON STAINLESS STEEL SHEET  2 mm THICK IN FLAT POSITION.(SMAW-24)</b>				TOLERANCE ±1	TIME 8 Hrs
					CODED NO. WLN1355E1	



## Job Sequence

- Prepare square edges.
- Clean the prepared edges.
- Select a 3.15 mm  $\varnothing$  stabilized electrode and set 100 amps current.
- Follow necessary safety precautions.
- Set and tack the pieces.
- Place copper chill plates on the job by the side of the joint.
- Keep the current low to reduce over heating of the electrode and job.
- Complete the weld in a single pass without weaving.
- Clean the weld and inspect the bead for surface defects.
- Use stainless steel wire brush and separate hand gloves for stainless steel welding. This helps to avoid ferrous contamination and corrosion.

## Skill Sequence

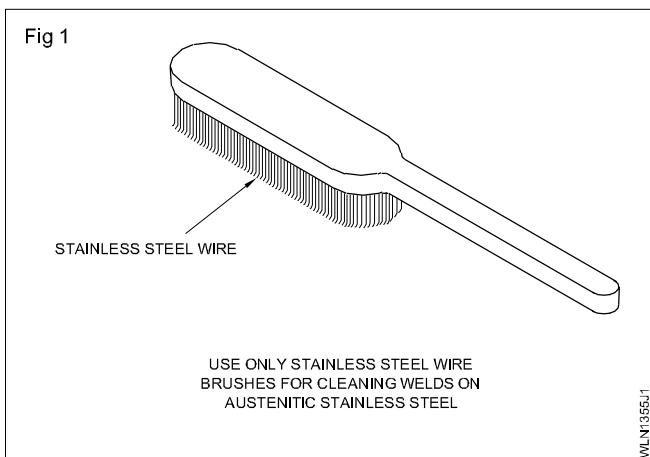
### Square butt joint on Stainless steel sheet 2mm thick in flat position

**Objective:** This shall help you to

- **prepare and weld square butt joint on stainless steel sheet 2mm thick in flat position.**

Prepare square edges by filing.

Remove burrs from the edges, and clean the edges with a stainless steel wire brush and remove the surface impurities. (Fig 1)



Take a 3.15 mm  $\varnothing$  stainless steel electrode and connect it to the positive side of the DC machine.

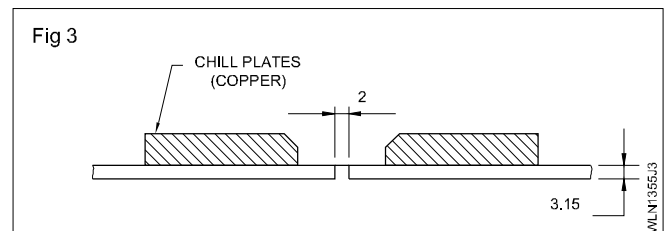
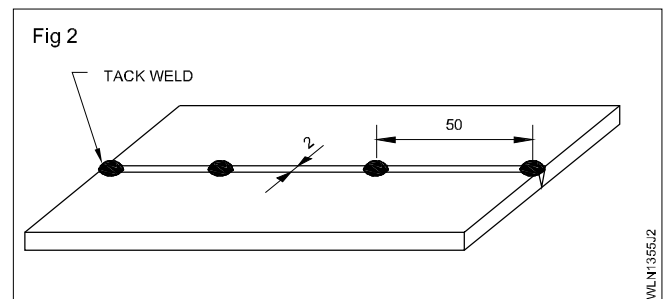
Columbium based electrodes (called stabilized stainless steel electrode) are used to avoid the welded joint getting corroded/rusted after welding.

Set the cleaned stainless steel plates on the work table with a uniform root gap of 2 mm as shown in Fig 2 and tack them at every 50 mm.

Clean the joint thoroughly to remove slag from the tacks.

Clamp chill plates adjacent to the joint to minimize distortion and buckling. (Fig 3)

To prevent damaging the metal surface, the polished side of a sheet should be placed down.



**Keep the current as low as possible to reduce overheating of the job.**

Start welding at the left hand side of the joint and maintain a short arc.

Do not weave the electrode.

The electrode angle must be 70° to 80° in the direction of the weld.

**Maintain a high welding speed to avoid overheating of the plate edges.**

Finish the welding at the right end of the plate.

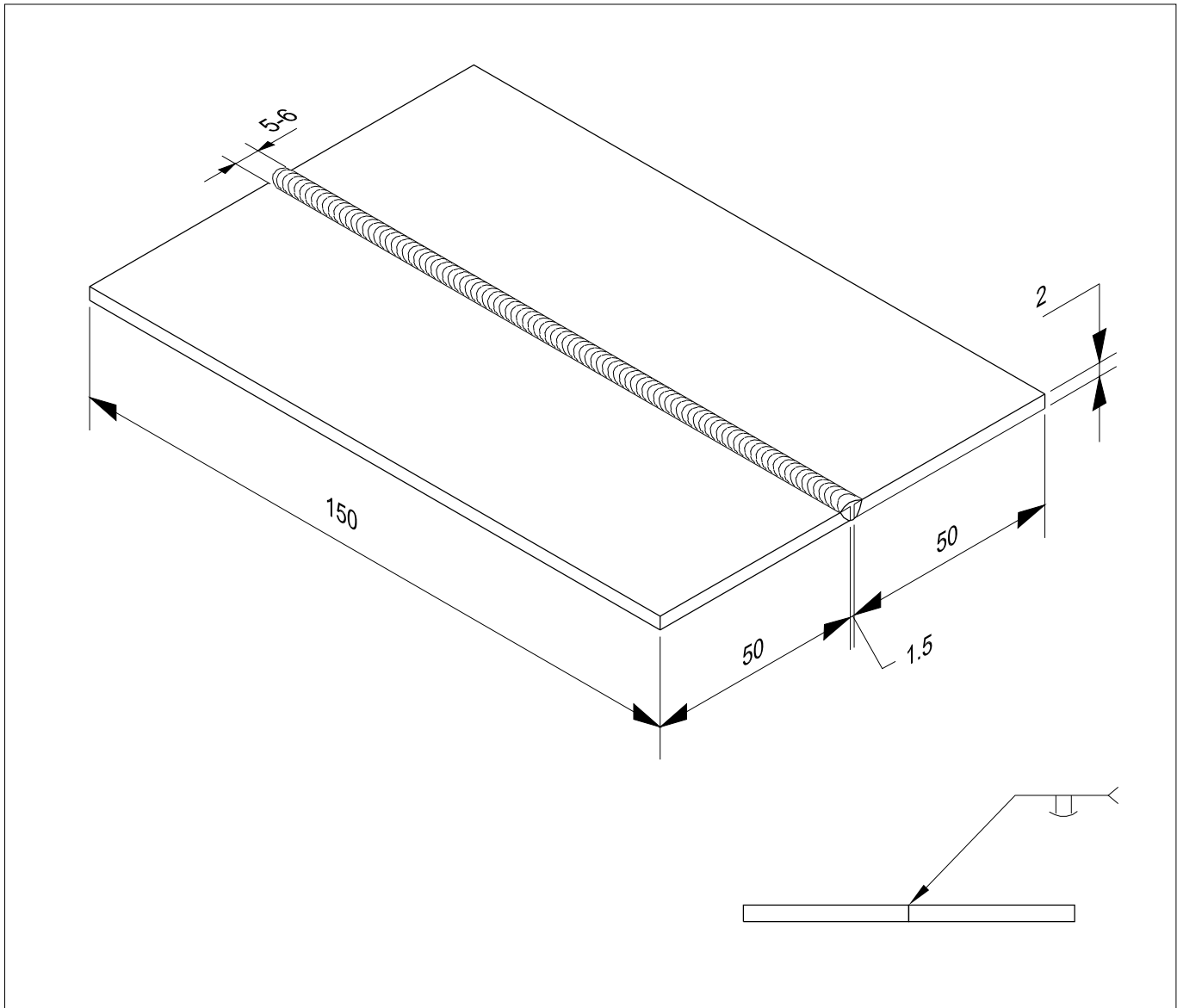
Deslag and clean thoroughly with a stainless steel wire brush.

Inspect for surface defects.

**Square butt joint on brass sheet 2mm thick in flat position (OAW-18)**

**Objectives:** At the end of this exercise you shall be able to

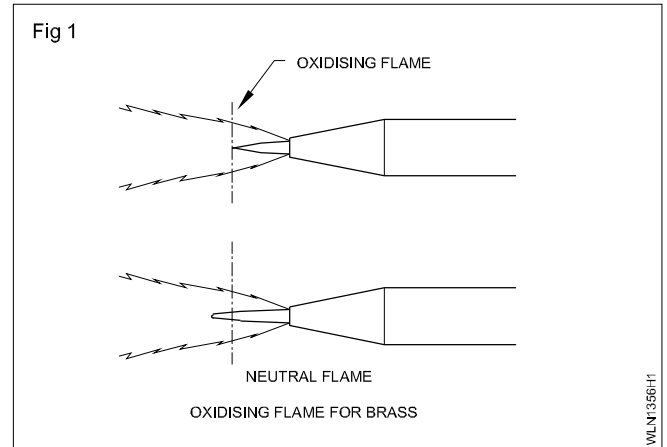
- remove oxides and other impurities from the surface of the base metal
- prepare a square edge and set the sheets as a butt joint
- select the correct size of nozzle and filler rod, gas pressure and flux
- set a soft oxidizing flame and tack-weld the butt joint
- manipulate the filler rod and blowpipe with appropriate angles and weld the joint
- clean and check the penetration and inspect the weld for weld defects.



2	150 x 50 x 2	-	CuZn30-O IS:2378	-	-	1.3.56
NO.OFF	STOCK SIZE	SEMI-PRODUCT	MATERIAL	PROJECT NO.	PART NO.	EX. NO.
SCALE NTS	<b>SQUARE BUTT JOINT ON BRASS SHEET 2 mm THICK IN FLAT POSITION(OAW-18)</b>				TOLERANCE ±1	TIME 09 Hrs
					CODE NO. WLN1356E1	

## Job Sequence

- Prepare the brass sheets as per dimension given in the sketch.
- Deburr the edges of the sheet.
- Clean the surfaces of the sheet and remove oxides if any.
- Select nozzle No. 5 and set 0.15 kg/cm<sup>2</sup> pressure for both the gases.
- Select a silicon-bronze rod of 1.5 mm  $\varnothing$ .
- Select brass flux (borax type). Apply the flux by dipping the hot end of the filler rod in the powdered flux from time to time.
- Set and align the plates with a root gap of 1.5 mm.
- Set a soft oxidizing flame. (Fig 1)
- Slightly preheat the plates before tacking and tack weld using 1.5mm $\varnothing$  filler rod. The pitch of tacks should be 50mm.
- Adopt leftward technique.



- Add the filler rod more rapidly as welding approaches the end of the seam. Fill the crater.
- Ensure complete removal of all flux residue.
- Clean the weld bead and inspect.
- Avoid inhaling zinc oxide fumes using a respirator.

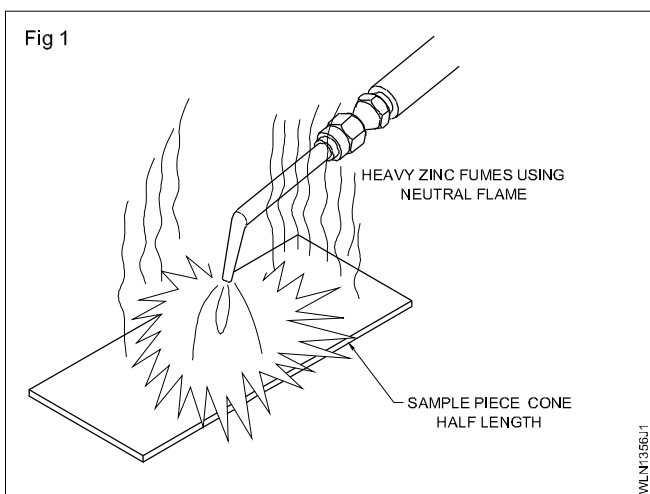
## Skill Sequence

### Square butt joint on brass plate 2mm thick in flat position

**Objective:** This shall help you to

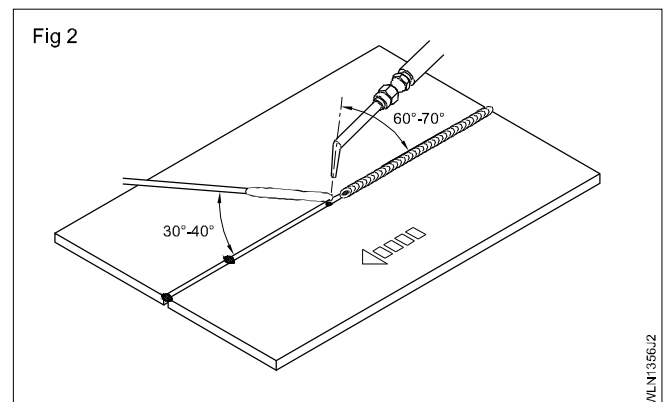
- **prepare and weld square butt joint on brass plate 2mm thick in flat position.**

Set a neutral flame and play over the sample brass piece. White zinc fumes will be seen. Then reduce the acetylene gas by operating the acetylene control valve in the blowpipe until the white fumes disappear. This is the required oxidizing flame for the particular brass sheet to be welded. (Fig 2)



Commence welding at right side end and continue until the joint is completed. The filler rod is fed into the pool as the surface sinks, indicating that penetration is being achieved.

The inner cone of the flame is held fairly close to the surface of the weld. Keep the angle of the blowpipe at 60°-70° and filler rod at 30°-40°. (Fig 3)



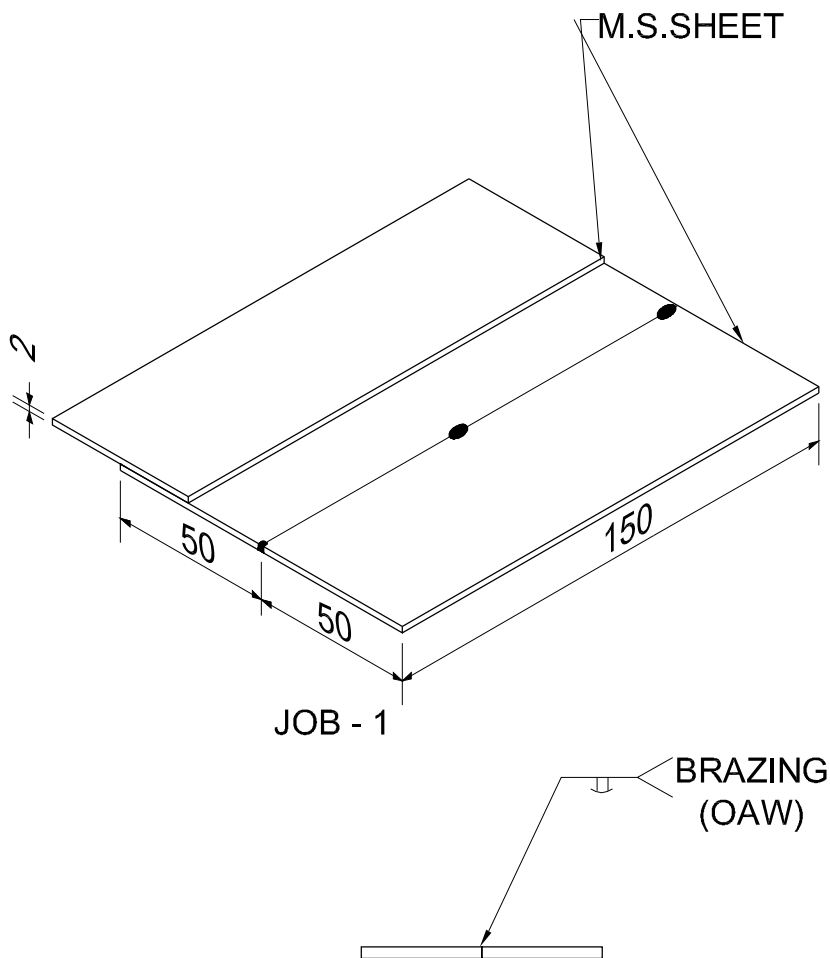
Reduce the blowpipe angle or withdraw entirely to reduce heat input at the crater.

A respirator is to be used to avoid inhaling of toxic zinc fume coming out of the brass sheet.

Square butt and lap joint on M.S. sheet 2mm thick by brazing in flat position (OAW-19)

Objectives: At the end of this exercise you shall be able to

- braze an M.S. square butt joint using oxidizing flame and brazing filler rod and flux
- remove the surface oxide and other impurities with wire wool
- select nozzle, filler rod, flux and flame for brazing
- clean the joint and inspect for surface defects.



3	ISST 50 x 2 - 150	-	Fe310 - W	-	-	1.3.57
NO.OFF	STOCK SIZE	SEMI-PRODUCT	MATERIAL	PROJECT NO.	PART NO.	EX. NO.
SCALE NTS	SQUARE BUTT AND LAP JOINT ON M.S SHEET 2MM THICK BY BRAZING IN FLAT POSITION (OAW-19)				TOLERANCE ±1	TIME 11 Hrs
					CODE NO. WLN1357E1	

## Job Sequence

- Cut the sheets as per drawing and file the edges to be joined square.
- Clean the joint area.
- Set the sheets as a square butt joint without root gap
- Select nozzle, filler rod, gas pressures, flux.
- Set oxidizing flame.
- Use leftward technique.
- Preheat the sheets and joint area to about 800°C.
- Dip the hot filler rod in flux and melt the filler rod into the joint ensuring proper wetting conditions.
- Avoid application of too much heat into the joint.
- Finish the joint in one run only.
- Clean the joint and inspect for weld defects like porosity etc, and for slight root penetration and proper bonding.
- Prepare a copper and a brass tube as per dimension.
- Clean and remove the surface oxides by wire wool.
- Select the nozzle No. 5 and 1.6mmø silicon bronze filler rod.
- Apply flux to the filler rod.
- Set the oxidizing flame.
- Manipulate the blowpipe and filler rod with flux applied on it using proper angles to fill the bell mouthed groove.
- Clean and remove the flux residue.
- Inspect for external weld defects.

## Skill Sequence

### Brazing of square and lap joint on MS sheet of 2mm thick

**Objective:** This shall help you to

- prepare and brazing of square and lap joint on MS sheet of 2mm thick.

#### Brazing of MS sheet (Job-1)

Oxidizing flame is used to avoid evaporation of zinc while brazing. Fig 1

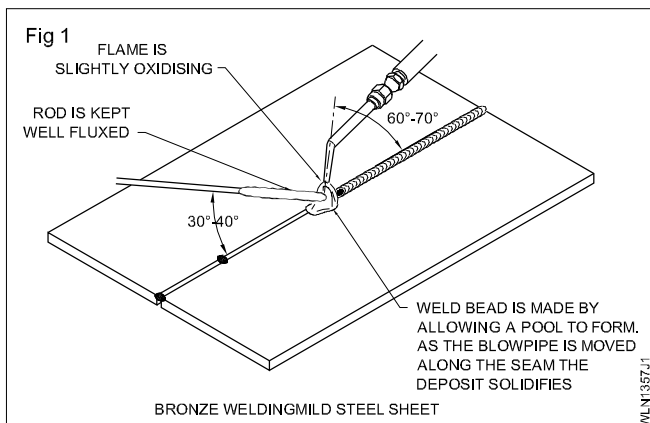
The blow pipe and filler rod is held at angles as shown in Fig 1.

A No. 3 size nozzle with 0.15 kg/cm<sup>2</sup> pressure for both gases is used as the base metal is not melted, but heated to around 800°C.

A 1.6mmø silicon bronze filler rod is used which helps free flow of molten filler metal.

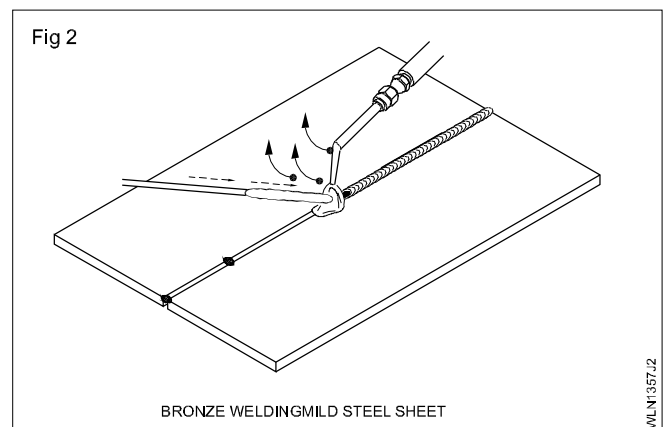
Direct the flame to the joint edges and tack weld at the ends and center of the joint. Fig 1.

Preheating the sheets to the correct temperature helps in proper wetting/spreading of the filler metal into the joint to get good bonding. Fig 1



The flame has to be directed only on the melting filler rod or the weld deposit in order to prevent oxidation or overheating of MS sheet.

After establishing the molten pool, the flame is withdrawn slightly (Fig 2) to permit the deposited metal freeze partially. Again reintroduce the filler rod to melt further deposit. Observe the brazed area carefully to ensure proper bonding is obtained and a uniform weld size is achieved.



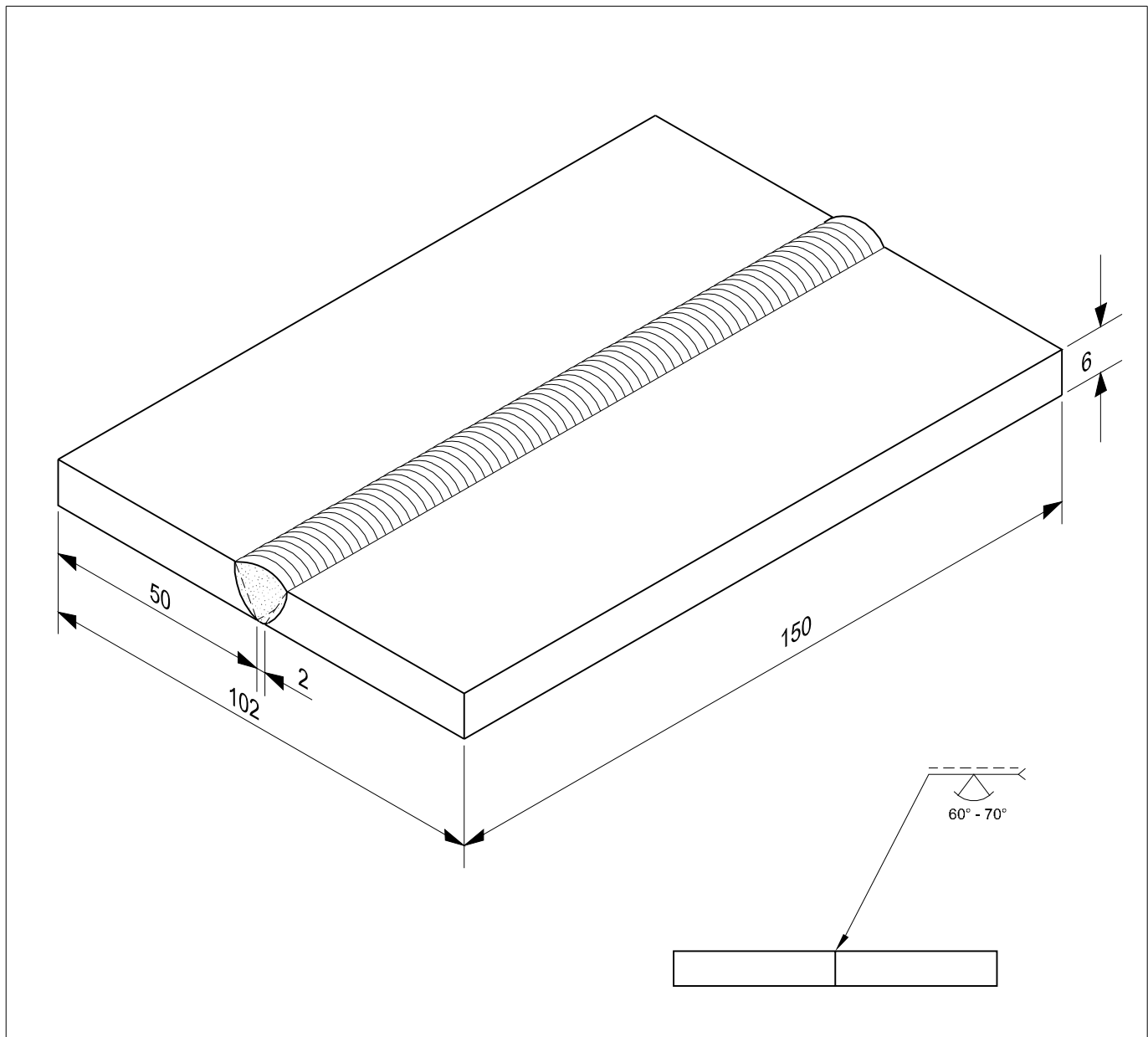
To avoid crater at the end of the weld the filler rod is continued to be added into the molten pool at the finishing point and the flame is withdrawn.

It is essential to remove any unused and residual flux on the finished weld to avoid corrosion later on.

Check the joint for proper bonding of filler metal with the base metal and proper root penetration by the filler metal. Check for weld defects like surface porosity, etc.

Single "V" butt joint on cast iron plate 6mm thick in flat position (1G) (SMAW-25)

- Objectives:** At the end of this exercise you shall be able to
- prepare the edges, set the cast iron plates and tack weld
  - preheat the plates and post heat the joint
  - select the electrode and set the current
  - deposit root run, second and third runs without crack
  - relieve the stresses from the joint by peening the bead
  - inspect the joint for defects.



2	150 x 50 x 6	-	FG 15	-	-	1.3.58
NO.OFF	STOCK SIZE	SEMI-PRODUCT	MATERIAL	PROJECT NO.	PART NO.	EX. NO.
SCALE NTS	<b>SINGLE "V" BUTT JOINT ON CAST IRON PLATE 6mm THICK IN FLAT POSITION (1G)-(SMAW-25)</b>				TOLERANCE ±1	TIME 11 Hrs
					CODE NO. WLN1358E1	

## Job Sequence

- Bevel the edges to 30° angle by grinding (or) filing maintain root face to 1.5mm.
- Keep the plates in alignment in flat position maintain a root gap of 2.50mm.
- Select low hydrogen type E7016 (or) E7018 electrode 3.15mm size and use DCEP polarity i.e., connect the electrode cable to the +ve terminal of the machine.
- Follow necessary safety precautions.
- Preheat the job to 300°C using a oxy-acetylene torch and check the temperature using a thermo chalk and tack weld on both ends using low hydrogen electrode.
- Keep the tack welded joint in flat position.
- Deposit the root run using ø3.15mm low hydrogen M.S. electrode ensuring root penetration.
- Clean the root run. Deposit 2<sup>nd</sup> and 3<sup>rd</sup> run using slight weaving and digging motion.
- Maintain minimum interpass temp 200°C throughout and also peen the weld bead by ball peen hammer to remove internal stress concentration for every run.
- Post heat the job if required and cover it in dry sand or ash to allow to cool slowly.
- Clean the weld and inspect it for cracks, proper fusion and other surface defects.

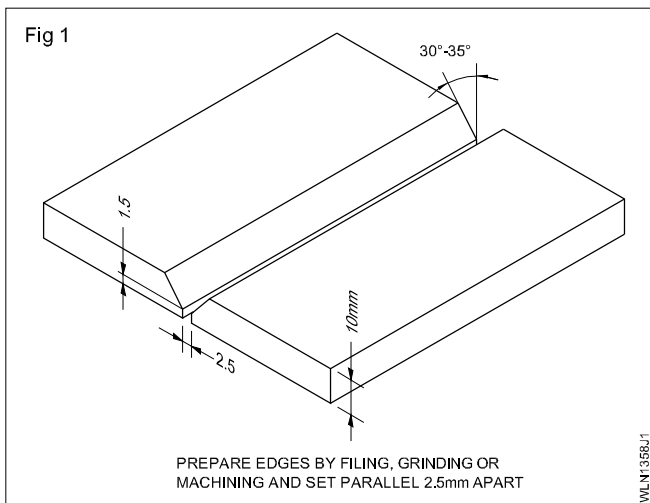
## Skill Sequence

### Single 'V' butt joint on cast iron plate

**Objective:** This shall help you to

- prepare and weld single 'V' butt joint on cast iron plate.

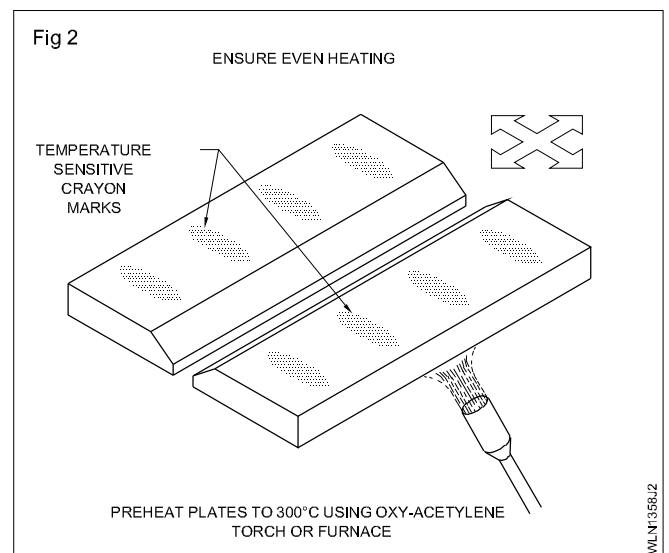
**Bevel the edges:** Bevel the edges to 30° angle by machining or filing. Maintain the root face 1.5 mm (Fig 1) avoid sharp edges as it may get chipped off if not handled properly.



**Set and tack weld:** Keep the job parallel in flat position and maintain the root gap 2.5 mm.

**Preheat the job:** Preheat the job at 300°C by using an oxy-acetylene flame. (Fig 2) Check the temperature by using a thermo chalk. (Figs 3a & 3b) Tack weld on both ends. (Fig 4)

**Deposition of runs:** Select a M.S. electrode (low hydrogen) 3.15 mm dia. and set the current at 130-140 amps with DCEP. (Electrode +ve) Deposit root run with electrode angle of 80° to the line of weld with medium arc length. AVOID SHORT ARC.

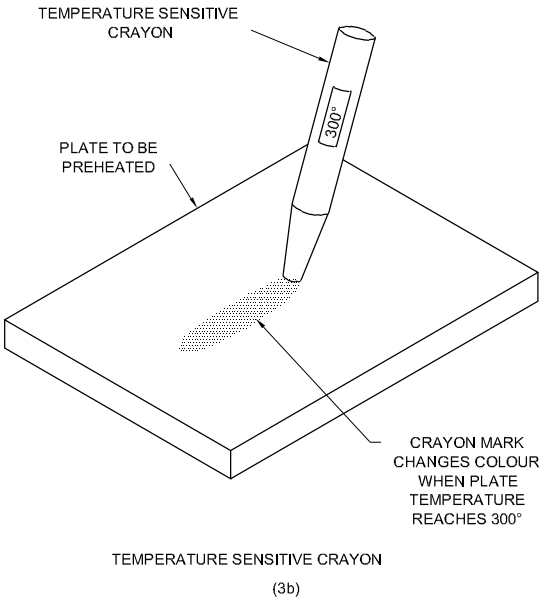
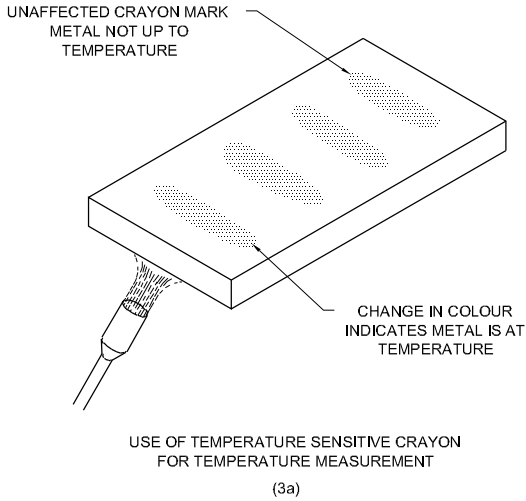


Clean the root run by a wire brush. Deposit the second the by using a 3.15 mm dia. electrode with slightly weaving motion and keep the electrode angle 80° to the line of weld. Move the electrode with a digging action. Since fluidity of cast iron is less, to make the molten metal to flow into the joint easily the electrode has to be given a digging action.

Clean the second run by a wire brush.

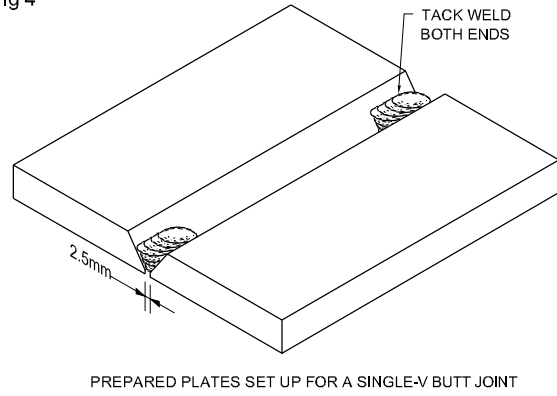
Deposit the third run by using a 3.15 mm dia. electrode with a slight weaving motion. Keep the electrode angle at 80° to the line of weld. Peen the welded bead by a ball peen hammer to remove internal stresses. Post heat the job to preheating temperature. Keep the job under dry sand or ash and allow to COOL SLOWLY. Clean the weldment by using a wire brush.

Fig 3



WLN1358J3

Fig 4



WLN1358J4

The use of low hydrogen electrode and the preheating, post heating, peening and slow cooling are essential to avoid cracks in the cast iron joint.

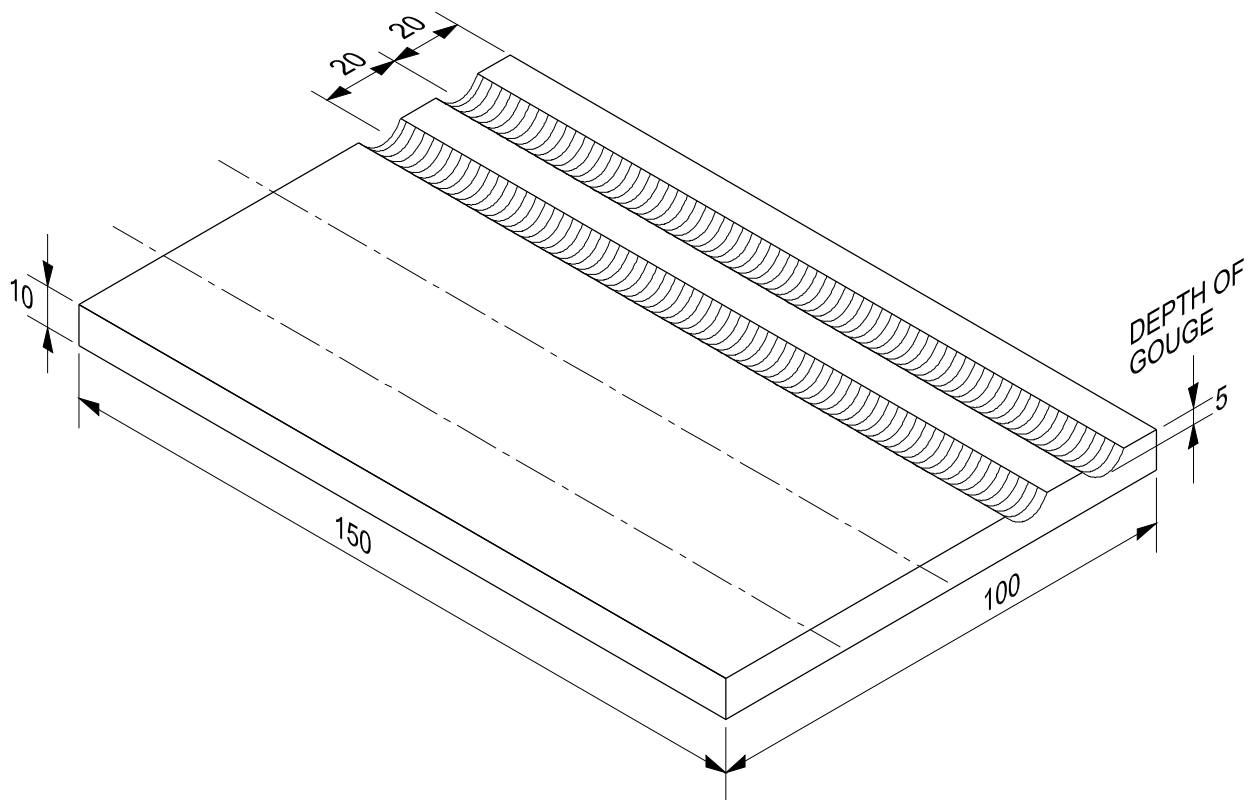
**Inspect the welds:** Inspect the welds for proper fusion, cracks and other surface defects.



**Arc gouging on MS plate 10mm thick (AG-01)**

**Objectives:** At the end of this exercise you shall be able to

- select the electrode and set the current as per requirements
- start and maintain gouging action
- clean and inspect the gouging.



1	100 ISF 10 - 150	-	Fe310 - W	-	-	1.3.33
NO.OFF	STOCK SIZE	SEMI-PRODUCT	MATERIAL	PROJECT NO.	PART NO.	EX. NO.
SCALE NTS	ARC GOUGING ON M.S.PLATE 10mm THICK IN FLAT POSITION.(AG-01)				TOLERANCE ±1	TIME 3 Hrs
					CODE NO. WLN1359E1	

## Job Sequence

- Mark and cut the pieces as per the given size.
- Mark and punch the straight line.
- Keep the plate in down hand position.
- Use 4mm dia electrode for 10mm thick plate and select DC electrode negative (DCEN).
- Set 300 amps current for both AC or DC machines and select DCEN if DC is used.
- Start from edge of the plate keeping a slant angle.
- When molten metal is established reduce the angle further to gouge and remove surface metal.
- While gouging is in progress remove molten metal and slag away from the arc and gouged groove.
- Move the electrode fast and control the gouging action.
- Complete the operation and clean the gouging surface.
- Inspect the groove for smoothness, even depth and uniformity.

## Skill Sequence

### Arc gouging on MS plate 10mm thick in flat position

**Objective:** This shall help you to

- **prepare and do the arc gouging on MS plate 10mm thick in flat position.**

**Prepare the pieces:** Mark and cut the pieces as per given sizes by gas cutting. Clean the surfaces. Mark and punch a straight line.

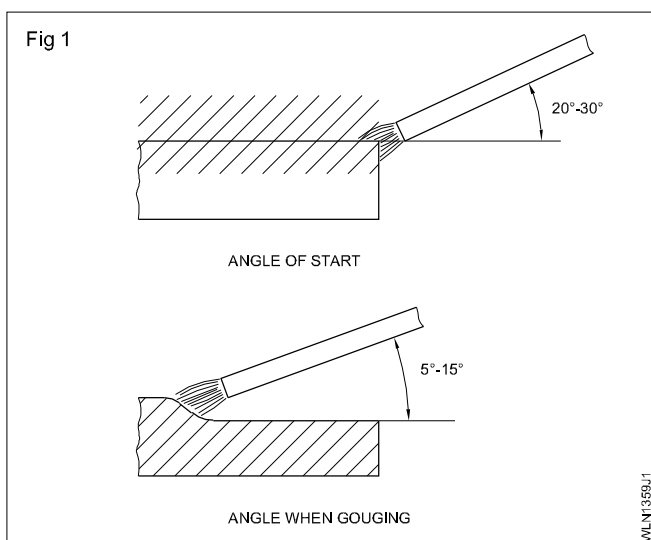
Position the plate down hand or flat.

#### Select the electrode and set the current.

Select a 4 mm dia. gouging electrode for a 10 mm thick plate.

Set 300 amps current in AC or DC m/c and if DC is used set the (straight polarity) electrode negative (DCEN).

**Gouging the plate:** Point the electrode towards one end of the edge with an angle of 20°-30° and 90° to the rear surface of the plate. (Fig 1)



Strike the arc.

**Wear a respirator while gouging.**

As the molten pool is established, lower the electrode holder and reduce the angle between 5°-15° from 20°-30°.

Move the electrode along the line of marking from the right to the left side of the plate without side movement.

While gouging is in progress push the molten pool and slag away from the arc and the gouged groove.

Due to rapid fusion because of the arc, heat, move the electrode fast and control the gouging operation.

**Ensure that the angle of slope is not too steep, and avoid grooving too deeply.**

**Use safety boots and leg guards to protect the legs.**

Maintain the angle and travel of electrode constant so as to obtain a groove of uniform width and depth.

Clean the gouging surfaces.

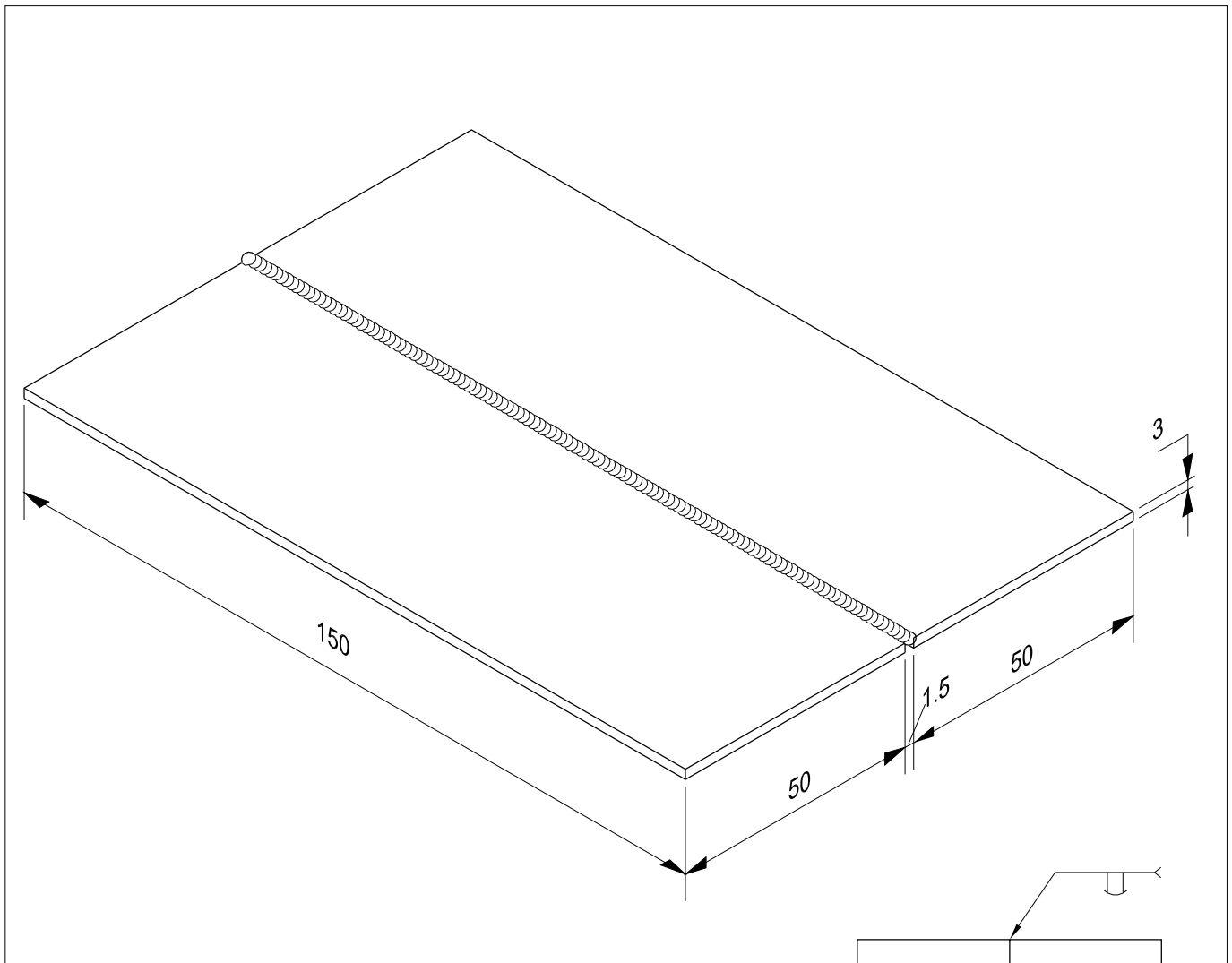
**Inspect the gouging.**

Check the smoothness, depth and uniformity of gouging.

Square butt joint on aluminium sheet 3mm thick in flat position (OAW-20)

Objectives: At the end of this exercise you shall be able to

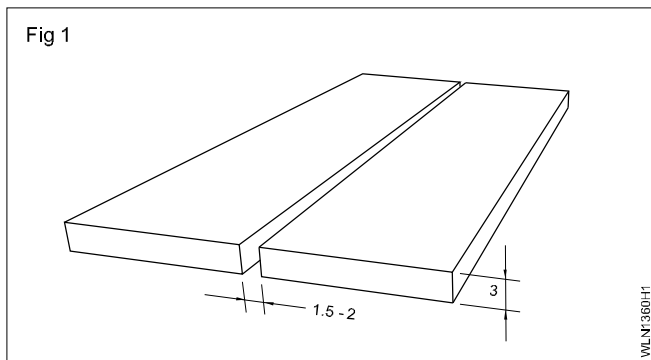
- set the sheets with sufficient root gap after cleaning the edges
- set proper flame, select filler rod, gas nozzle, gas, pressures and flux
- preheat the job to the required temperature
- weld aluminium butt joint
- ensure fusion of edges without making holes at the joint
- remove flux residues from the weldment by chemical cleaning
- inspect for weld defects.



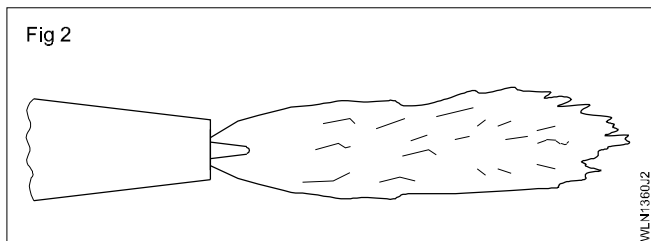
2	150 x 50 x 3	-	AL.199990-IS:737	-	-	1.3.60
NO.OFF	STOCK SIZE	SEMI-PRODUCT	MATERIAL	PROJECT NO.	PART NO.	EX. NO.
SCALE NTS	SQUARE BUTT JOINT ON ALUMINIUM SHEET 3mm IN FLAT POSITION. (OAW-20)				TOLERANCE ±0.5	TIME 12 Hrs
					CODE NO. WLN1360E1	

## Job Sequence

- Prepare aluminium sheet as per dimension with square edges.
- Clean the surface and edges of the sheets to remove the surface oxide and other impurities using stainless steel wire brush/solvent.
- Don't grind aluminium sheets in a grinding machine.
- Apply the pasty flux on the butting edges.
- Set the sheets with 1.5 mm - 2 mm root gap. (Fig 1) As the thermal expansion of aluminium is more, the root gap can be set such that it increases at about 1mm per 100mm length of the joint for butt welds.



- Fix nozzle No. 5 on the blow pipe and adjust gas pressure of 0.15 kg/sq.cm<sup>2</sup> for both gases.
- Adjust a strict neutral flame. (Fig 2)



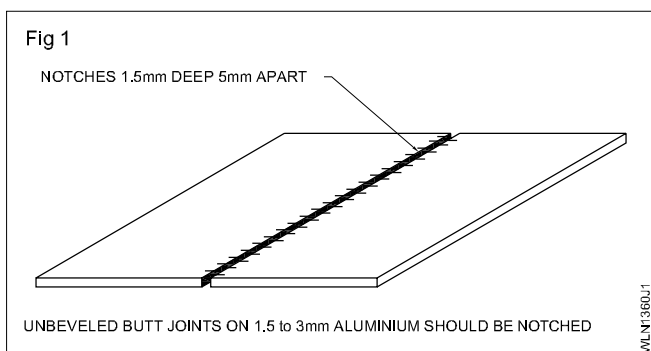
## Skill Sequence

### Square butt joint on aluminium sheet of 3mm thick

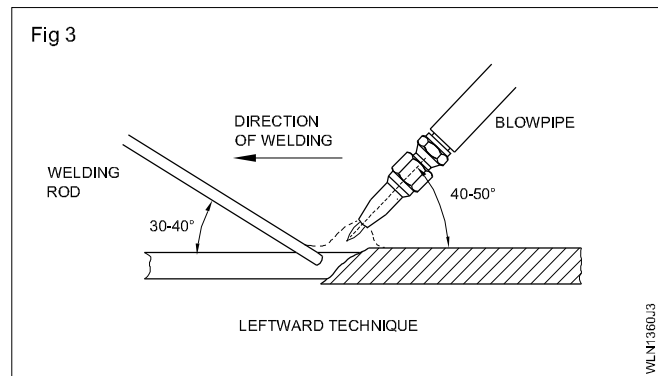
**Objective:** This shall help you to

- **prepare and weld square butt joint on aluminium sheet of 3mm thick.**

While preparing square edges make notches on the edges to be joined. Fig 1



- Use silicon aluminium filler rod 3 mm  $\varnothing$  and apply the pasty flux on the filler rod.
- Tack-weld at both ends of the joint and at the center.
- Preheat the job to a temperature of 150° - 180°C to reduce the effect of expansion during welding using the blow pipe flame itself.
- Start welding by the leftward technique by holding the blowpipe at an angle of 40° to 50° and the filler rod at an angle of 30° - 40°. (Fig 3)

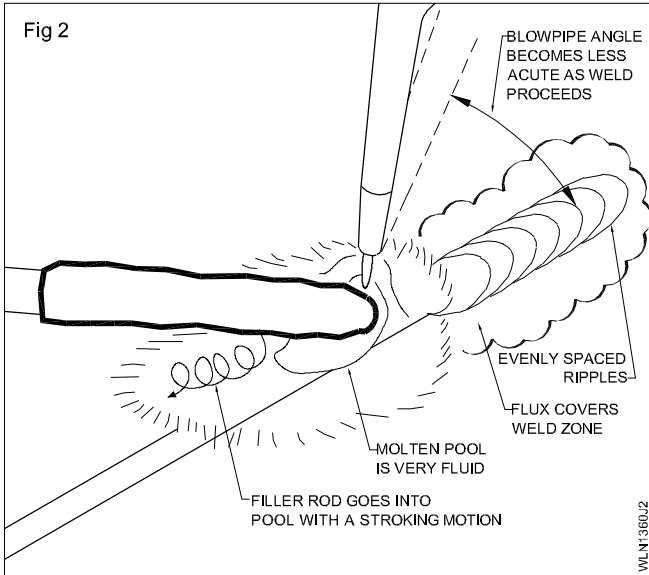


- Do not remove the filler rod end from the outer envelope of the flame till the welding is over.
- Clean the weld by washing in a 10% sulphuric acid solution.
- Again wash the weld by rinsing in hot or cold water.
- No traces of flux should remain on the weld. It will cause corrosion, after completion of the weld.
- Inspect for weld defects.
- As the end of the joint is approached, reduce the blow pipe and filler rod angle and raise the inner cone. This is done to avoid burn through of the joint.

Since setting a strict neutral flame is difficult a very slight carburizing flame is set for welding aluminium.

While using leftward technique, the blow pipe angle will be reduced gradually as the welding progresses. Fig 2.

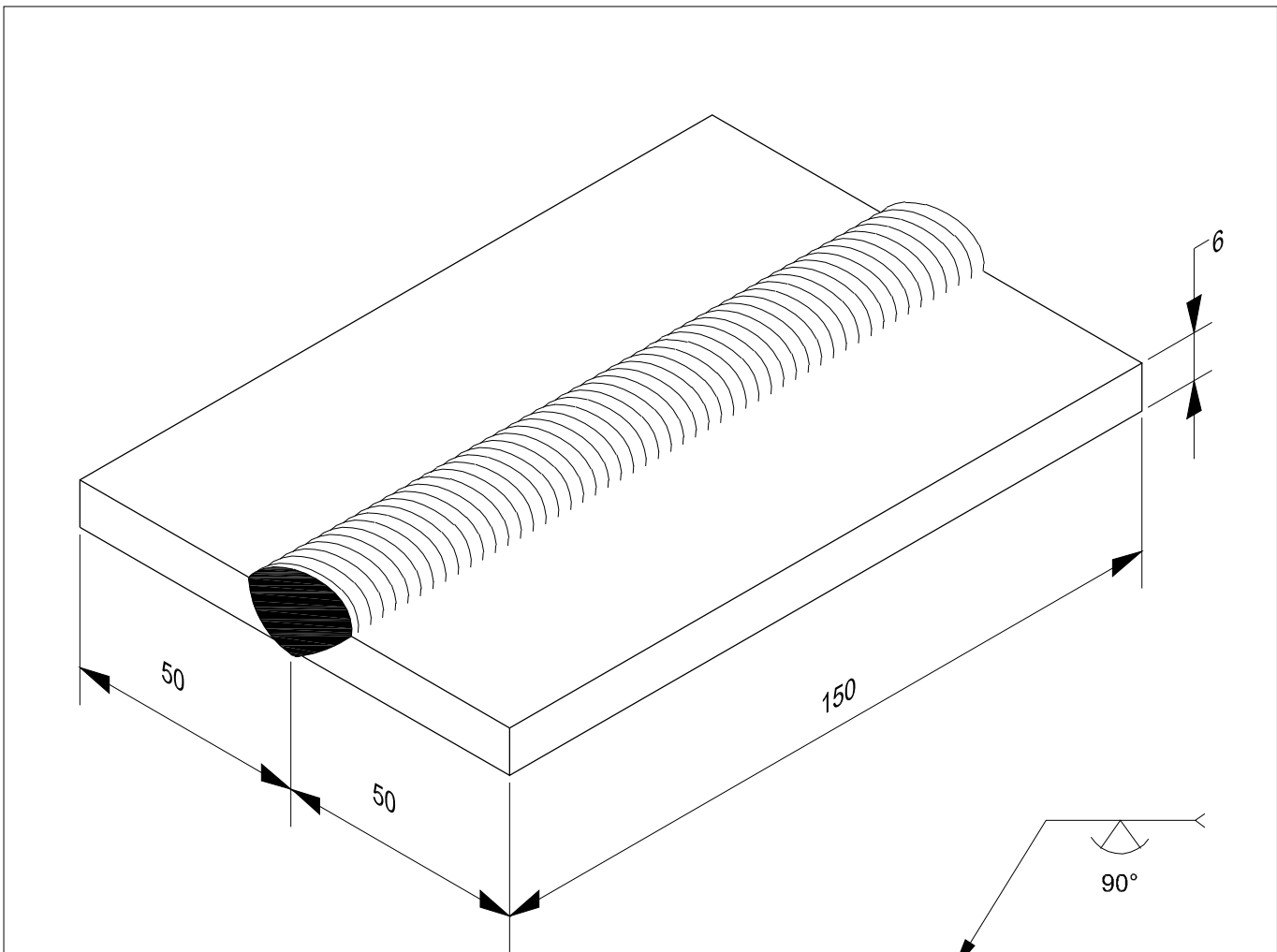
As there is no colour change when aluminium melts, watch carefully for any shrinking of oxide film on the surfaces of the base metal which indicates the starting of base metal melting.



**Bronze welding of single "V" butt joint on cast iron plate 6mm thick plate (1G) (OAW-21)**

**Objectives:** At the end of this exercise you shall be able to

- clean the job pieces from oil grease, etc. and remove oxides from the surface of the parent metal
- select the correct nozzle size and filler rod (composition and size)
- set a slightly oxidized flame
- select and identify the correct type of flux and method of application of flux
- manipulate the blowpipe and filler rod in appropriate procedure during welding
- clean and check for defects on the weldment.



2	150 x 50 x 6	-	FG15	-	-	1.3.61
NO.OFF	STOCK SIZE	SEMI-PRODUCT	MATERIAL	PROJECT NO.	PART NO.	EX. NO.
SCALE NTS	BRONZE WELDING OF SINGLE 'V' BUTT JOINT ON 6 mm THICK CAST IRON PLATE IN FLAT POSITION. (1G)-(OAW-21)				TOLERANCE ±1	TIME 13 Hrs
					CODE NO. WLN1361E1	

## Job Sequence

- Clean the surface of the work piece from oil, grease, dirt and remove oxides if any by filing/grinding.
- Grind the edges of the plate to (no feather edge) form a single V of included angle of 90°. Round off all sharp edges.
- Select nozzle No.10.
- Select a silicon bronze filler rod of 3mmø for the root run and 5mmø for the 2nd run.
- Select bronze flux and 0.15 kg/cm<sup>2</sup> pressure for both gases.
- Ensure all safety precautions before lighting the torch.
- Set a soft oxidizing flame.
- Apply flux in powder form by dipping hot filler rod. Then tack weld on both ends of the joint with a uniform root gap of 2.5mm.
- Weld the root run using leftward technique and 3mmø filler rod keeping the job at 30° slope.
- Ensure wetting of weld faces by the filler metal before building up the bead.
- Heat the weld faces only to dull red color by giving circular motion to the blow pipe.

**It is not necessary to melt the base metal for bronze welding of cast iron.**

- Clean the root run and deposit the 2nd run using 5mm filler rod after applying flux.
- Fill the joint by filler metal to get a maximum of 1.5mm reinforcement, good ripple formation.
- Clean the joint removing any flux residue and inspect for defects.
- Heat control is important. If the heat is insufficient the bronze metal will not wet the surface or flow properly.
- Excess heat will cause the bronze metal to flow more freely and not allow it to build up.

## Skill Sequence

### Bronze welding of single 'V' butt joint on cast iron plate of 6mm thick

**Objective:** This shall help you to

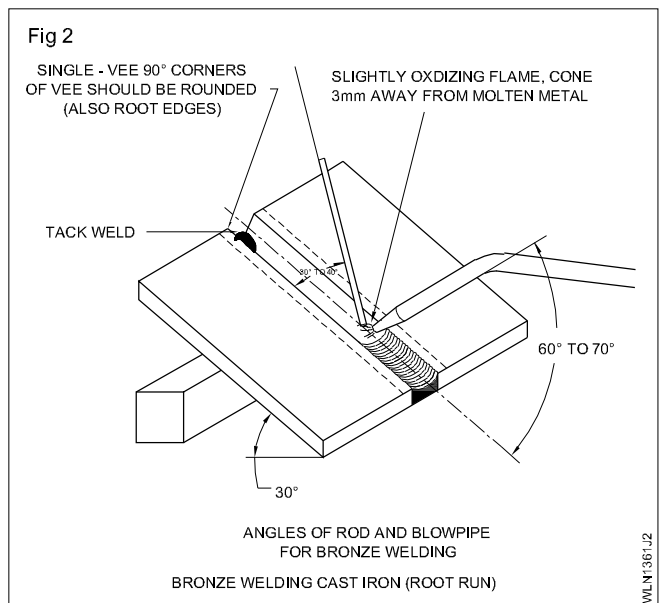
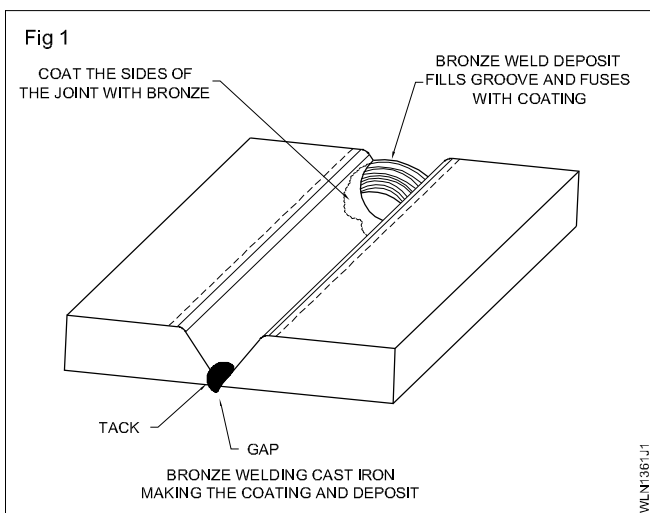
- prepare and bronze welding of single 'V' butt joint on cast iron plate of 6mm thick.

Set the job with 30° inclinations. Keep the angle of the filler rod at 30° to 40° and give a rubbing action to the filler rod on the V.

Maintain the angle of the blowpipe at 60° to 70° and give a circular motion to the blowpipe. (Fig 2)

Deposit a root run with a 3mmø filler rod and the finishing run with a 5mmø filler rod. Dip the hot filler rod end into the powdered bronze flux frequently.

In bronze welding of cast iron the base is only heated to 650°C and it is not melted. So while depositing the root run the surfaces of the joint is coated with a layer of filler metal for about 20mm along the joint, ensuring that it is correctly bonded. Fig 1.



Then return to the starting point and add sufficient filler metal to produce a satisfactory weld. This method is repeated continuously until the root run is completed. Fig 2 Ensure root penetration by the filler metal and fusion between consecutive bronze filler metal deposits.

Weld similarly the 2nd run by using 5mm $\varnothing$  filler rod dipped in flux with a soft oxidizing flame and get 1.5mm reinforcement and good bead up to the end of the joint. Fig 3.

Clean the bead and remove the flux residue on both sides of the joint.

Inspect the joint for weld defects like porosity, incomplete penetration etc.

